

MICROACTIVE ASAP[®] 2020

ACCELERATED SURFACE AREA AND POROSIMETRY SYSTEM



micromeritics[®]

**Effective Solutions for
Material Characterization**

OPERATOR MANUAL

202-42804-01
Feb 2019
(Rev-)

TRADEMARKS

Alconox is a registered trademark of the Alconox Company.

ASAP is a registered trademark of Micromeritics Instrument Corporation.

Chemraz is a registered trademark of Green, Tweed.

Kalrez is a registered trademark of DuPont Dow Elastomers L.L.C.

MATLAB is a registered trademark of MathWorks.

Micromeritics is a registered trademark of Micromeritics Instrument Corporation.

Microsoft and Windows are registered trademarks of Microsoft Corporation.

Python is a registered trademark of Python Software Foundation.

Teflon is a registered trademark of E. I. DuPont de Nemours Company.

This application may contain a binary form of the Info-ZIP tool to create .zip files. That source code is provided under the following license:

This software is provided "as is," without warranty of any kind, express or implied. In no event shall Info-ZIP or its contributors be held liable for any direct, indirect, incidental, special or consequential damages arising out of the use of or inability to use this software.

Permission is granted to anyone to use this software for any purpose, including commercial applications, and to alter it and redistribute it freely, subject to the following restrictions:

1. Redistributions of source code must retain the above copyright notice, definition, disclaimer, and this list of conditions.
2. Redistributions in binary form must reproduce the above copyright notice, definition, disclaimer, and this list of conditions in documentation and/or other materials provided with the distribution.
3. Altered versions — including, but not limited to, ports to new operating systems, existing ports with new graphical interfaces, and dynamic, shared, or static library versions — must be plainly marked as such and must not be misrepresented as being the original source. Such altered versions also must not be misrepresented as being Info-ZIP releases — including, but not limited to, labeling of the altered versions with the names "Info-ZIP" (or any variation thereof, including, but not limited to, different capitalizations), "Pocket UnZip," "WiZ" or "MacZip" without the explicit permission of Info-ZIP. Such altered versions are further prohibited from misrepresentative use of the Zip-Bugs or Info-ZIP e-mail addresses or of the Info-ZIP URL(s).
4. Info-ZIP retains the right to use the names "Info-ZIP," "Zip," "UnZip," "WiZ," "Pocket UnZip," "Pocket Zip," and "MacZip" for its own source and binary releases.

Copyright

The software described in this manual is furnished under a license agreement and may be used or copied only in accordance with the terms of the agreement.

WARRANTY

MICROMERITICS INSTRUMENT CORPORATION warrants for one year from the date of shipment each instrument it manufactures to be free from defects in material and workmanship impairing its usefulness under normal use and service conditions except as noted herein.

Our liability under this warranty is limited to repair, servicing and adjustment, free of charge at our plant, of any instrument or defective parts when returned prepaid to us and which our examination discloses to have been defective. The purchaser is responsible for all transportation charges involving the shipment of materials for warranty repairs. Failure of any instrument or product due to operator error, improper installation, unauthorized repair or alteration, failure of utilities, or environmental contamination will not constitute a warranty claim. The materials of construction used in MICROMERITICS instruments and other products were chosen after extensive testing and experience for their reliability and durability. However, these materials cannot be totally guaranteed against wear and/or decomposition by chemical action (corrosion) as a result of normal use.

Repair parts are warranted to be free from defects in material and workmanship for 90 days from the date of shipment.

No instrument or product shall be returned to MICROMERITICS prior to notification of alleged defect and authorization to return the instrument or product. All repairs or replacements are made subject to factory inspection of returned parts.

MICROMERITICS shall be released from all obligations under its warranty in the event repairs or modifications are made by persons other than its own authorized service personnel unless such work is authorized in writing by MICROMERITICS.

The obligations of this warranty will be limited under the following conditions:

1. Certain products sold by MICROMERITICS are the products of reputable manufacturers, sold under their respective brand names or trade names. We, therefore, make no express or implied warranty as to such products. We shall use our best efforts to obtain from the manufacturer, in accordance with his customary practice, the repair or replacement of such of his products that may prove defective in workmanship or materials. Service charges made by such manufacturer are the responsibility of the ultimate purchaser. This states our entire liability in respect to such products, except as an authorized person of MICROMERITICS may otherwise agree to in writing.
2. If an instrument or product is found defective during the warranty period, replacement parts may, at the discretion of MICROMERITICS, be sent to be installed by the purchaser, e.g., printed circuit boards, check valves, seals, etc.
3. Expendable items, e.g., sample tubes, detector source lamps, indicator lamps, fuses, valve plugs (rotor) and stems, seals and O-rings, ferrules, etc., are excluded from this warranty except for manufacturing defects. Such items which perform satisfactorily during the first 45 days after the date of shipment are assumed to be free of manufacturing defects.

Purchaser agrees to hold MICROMERITICS harmless from any patent infringement action brought against MICROMERITICS if, at the request of the purchaser, MICROMERITICS modifies a standard product or manufactures a special product to the purchaser's specifications.

MICROMERITICS shall not be liable for consequential or other type damages resulting from the use of any of its products other than the liability stated above. This warranty is in lieu of all other warranties, express or implied, including but not limited to, the implied warranties of merchantability or fitness for use.

CORPORATE PROFILE

Micromeritics Instrument Corporation is a leading global provider of solutions for material characterization with best-in-class instrumentation and application expertise in five core areas: density; surface area and porosity; particle size and shape; powder characterization; and catalyst characterization and process development. Founded in 1962, the company is headquartered in Norcross, Georgia, USA and has more than 300 employees worldwide. With a fully integrated operation that extends from a world class scientific knowledge base through to in-house manufacture, Micromeritics delivers an extensive range of high-performance products for academic research and industrial problem-solving. The implementation of tactical partnerships to incubate and deliver valuable new technologies exemplifies the company's holistic, customer-centric approach which extends to a cost-efficient contract testing laboratory – the Particle Testing Authority (PTA). The strategic acquisitions of Freeman Technology Ltd and Process Integral Development S.L. (PID Eng & Tech) reflect an ongoing commitment to optimized, integrated solutions in the industrially vital areas of powders and catalysis.

Freeman Technology (Tewkesbury, UK) brings market-leading powder characterization technology to Micromeritics' existing portfolio of particle characterization techniques. The result is a suite of products that directly supports efforts to understand and engineer particle properties to meet powder performance targets. With over 15 years of experience in powder testing, Freeman Technology specializes in systems for measuring the flow properties of powders. In combination with detailed application know-how these systems deliver unrivalled insight into powder behavior supporting development, formulation, scale-up, processing and manufacture across a wide range of industrial sectors.

PID Eng & Tech (Madrid, Spain) complements Micromeritics' renowned offering for catalyst characterization with technology for the measurement and optimization of catalytic activity, with a product range that extends to both standard and bespoke pilot scale equipment. Launched in 2003, PID Eng & Tech is a leading provider of automated, modular microreactor systems for the detailed investigation of reaction kinetics and yield. These products are supported by a highly skilled multidisciplinary team of engineers with in-depth expertise in the design, construction and operation of laboratory units and process scale-up.

The Particle Testing Authority (PTA) provides material characterization services for fine powders and solid materials using Micromeritics' instrumentation alongside complementary solutions from other vendors. With the certification and expertise to operate across a wide range of industries the PTA offering runs from single sample analysis to complex method development, method validation, new product assessment, and the analytical support required for large scale manufacturing projects. An experienced, highly trained team of scientists, engineers, and lab technicians works closely with every client to ensure that all analytical requirements are rapidly and responsively addressed.

Micromeritics has a strong global network with offices across the Americas, Asia, and Europe complemented by a dedicated team of distributors in additional locations. This ensures that local, knowledgeable support is available for every customer, in academia or industry. Micromeritics works across a truly diverse range of industries from oil processing, petrochemicals and catalysts, to food and pharmaceuticals, and at the forefront of characterization technology for next generation materials such as graphene, metal-organic-frameworks, nanocatalysts, and zeolites. Engineering solutions that work optimally for every user is a defining characteristic of the company.

CONTACT US

Micromeritics Instrument Corporation

4356 Communications Drive
Norcross, GA / USA / 30093-2901
Phone: 1-770-662-3636
Fax: 1-770-662-3696
www.Micromeritics.com

Instrument Service or Repair

Phone: 1-770-662-3666
International — contact your local distributor or call 1-770-662-3666
Service.Helpdesk@Micromeritics.com

Micromeritics Learning Center

Phone: 1-770-662-3607
www.Micro.edu

ABOUT THIS MANUAL

Log in to your [customer portal](#) to access the following:

- Calculations
- Error Messages
- MicroActive ASAP 2020 Operator Manual in PDF format
- MicroActive Report Tutorials
- Smart VacPrep Operator Manual in PDF format



Parts and accessories can be found online at www.Micromeritics.com.



All references to ASAP 2020 in this document encompass the optional ASAP 2020A unless otherwise noted. References to chemisorption (or ) are not applicable to the optional ASAP 2020A analyzer.

The following icons may be found in this manual:

Common Icons

Icon	Refers to
	Chemical Adsorption only (not applicable to the ASAP 2020A)
	Physical Adsorption only



NOTE — Notes contain important information applicable to the topic.



CAUTION — Cautions contain information to help prevent actions that may damage the analyzer or components.



WARNING — Warnings contain information to help prevent actions that may cause personal injury.

To view the full EC Declaration of Conformity document, visit the Micromeritics web page at www.Micromeritics.com.

Original Instructions (English)
Part Number 202-42804-01 (Rev -) Released Feb 2019
Copyright 2019
Micromeritics Instrument Corporation
4356 Communications Drive
Norcross, GA / USA / 30093-2901

Blank Page

Table of Contents

Warranty	<i>i</i>
Corporate Profile	<i>ii</i>
Contact Us	<i>iii</i>
About this Manual	<i>iv</i>
1 Analyzer Components for ASAP 2020	1 - 1
Analyzer Components for ASAP 2020A	1 - 6
Equipment Options and Upgrades	1 - 8
Gas Requirements	1 - 9
Specifications for ASAP 2020 and 2020A	1 - 10
2 About the Software	2 - 1
Software Setup	2 - 1
Menu Structure	2 - 2
Common Fields and Buttons	2 - 3
File Status, Description, Extension, and Location	2 - 6
Keyboard Shortcuts	2 - 8
Option Presentation	2 - 10
Libraries	2 - 12
Methods	2 - 13
Configure the Analyzer	2 - 15
Unit Configuration	2 - 15
Unit Selections	2 - 17
Instrument Status	2 - 18
Show Instrument Log	2 - 18
Show Instrument Schematic	2 - 19
Show Status	2 - 22
Export Files	2 - 23
List Files	2 - 23

Software Uninstall	2 - 24
Software Updates	2 - 24
3 Sample Files	3 - 1
Create Sample Files	3 - 2
Open a Sample File	3 - 5
Manually Enter Data	3 - 5
Active Metals for Chemical Adsorption	3 - 9
4 Parameter Files	4 - 1
Adsorptive Properties	4 - 2
Analysis Conditions	4 - 5
Chemical Adsorption Tasks	4 - 14
Evacuation Rules for Chemical Adsorption	4 - 17
Degas Conditions	4 - 18
Report Options	4 - 20
Sample Tube for Physisorption	4 - 23
5 Degassing	5 - 1
Start Degas	5 - 1
Transfer a Degassed Physical Adsorption Sample to an Analysis Port	5 - 2
Transfer a Degassed Chemical Adsorption Sample to an Analysis Port	5 - 4
Enable Manual Control of Degas Ports	5 - 5
Show Degas Status	5 - 6
Show Degas Schematic	5 - 7
6 Perform an Analysis	6 - 1
Dewar Precautions	6 - 1
Prepare for Analysis	6 - 3
Select a Sample Tube	6 - 4
Clean and Label Sample Tubes	6 - 5
Create the Sample File	6 - 7
Determine the Sample Mass	6 - 8

Degas the Sample	6 - 13
Sample Tube Installation	6 - 16
Fill and Install the Dewar	6 - 19
Perform a Sample Analysis	6 - 21
Perform an Analysis Sequence for Chemical Adsorption	6 - 23

7 About Reports **7 - 1**

Heat of Adsorption Report	7 - 2
SPC Report for Physical Adsorption	7 - 4
Regression Report for Physical Adsorption	7 - 5
Control Chart Report for Physical Adsorption	7 - 7
Interactive Reports	7 - 10
MicroActive Reports	7 - 11
Evaluate Report Results	7 - 11
Report Features and Shortcuts	7 - 16
Graph Features and Shortcuts	7 - 20
Graph and Sample Overlays	7 - 26
Generate Pore Size Distribution Graph Overlays	7 - 26
Overlay Multiple Sample Files	7 - 29
Import ASCII Pore Distribution Data	7 - 32
Report Examples	7 - 33
Horvath-Kawazoe Differential Pore Volume Plot	7 - 33
Isotherm Log Report	7 - 34
Isotherm Tabular Report	7 - 35
Options Report	7 - 36

8 Selected Reports **8 - 1**

Advanced Report Options	8 - 1
Alpha-S Method Report Options	8 - 2
BET Surface Area Report Options	8 - 4
BJH Adsorption/Desorption Report Options	8 - 6
DFT Pore Size Report Options	8 - 12
DFT Surface Energy Report Options	8 - 14

Difference Method Report Options for Chemical Adsorption	8 - 15
Dollimore-Heal Adsorption/Desorption Report Options	8 - 18
Dubinin Report Options	8 - 23
f-Ratio Method Report Options	8 - 28
Freundlich Report Options	8 - 30
Horvath-Kawazoe Report Options	8 - 33
Isotherm Report Options	8 - 37
Langmuir Report Options	8 - 39
MP-Method Report Options	8 - 42
NLDFT Advanced PSD Report	8 - 46
Options Report	8 - 50
Sample Log Report	8 - 50
Sinfelt and Difference Methods for Chemical Adsorption	8 - 51
Summary Report Options	8 - 52
t-Plot Report Options	8 - 54
Temkin Report Options	8 - 57
Validation Report Options	8 - 60
9 Diagnostics	9 - 1
Start Diagnostic Test	9 - 1
Schedule Diagnostic Tests	9 - 3
Diagnostic Test Report	9 - 4
Save Files for Problem Diagnosis	9 - 5
Show All Readings	9 - 6
10 Calibration	10 - 1
Calibrate Furnace Resistance	10 - 1
Calibrate Pressure Zero	10 - 2
Load Calibration from File	10 - 3
Save Calibration to File	10 - 3
11 Hardware	11 - 1
Cold Trap Option	11 - 1

Cold Trap Dewar Installation	11 - 1
Cold Trap Tube Installation	11 - 2
Furnace	11 - 3
Chemical Adsorption Port Assembly	11 - 3
Attach the Furnace	11 - 4
Heating Mantle Installation	11 - 5
Mass Spectrometer Installation	11 - 6
Sample Tube Installation	11 - 6
12 Troubleshooting and Maintenance	12 - 1
Guidelines for Connecting Gases	12 - 3
Replace a Gas Cylinder	12 - 4
Set the Gas Flow Rates for Chemical Adsorption	12 - 7
Oil-based Vacuum Pump	12 - 8
Service Test Mode	12 - 8
Preventive Maintenance	12 - 9
Check and Clean the Dewar	12 - 10
Clean the Analyzer	12 - 11
Clean the Cold Trap Tube	12 - 12
Enable Manual Control	12 - 13
Lubricate the Elevator Drive Assembly	12 - 13
Port Filters	12 - 14
Replace the Psat Tube O-ring	12 - 17
Replace the Sample Tube O-ring	12 - 18
Power Instrument On and Off	12 - 21
Recover from a Power Failure	12 - 21
A Atomic Weights and Cross Sectional Areas	A - 1
B Calculate Free Space Values for Micropore Analyses	B - 1
C Chemical Adsorption Methods	C - 1
Platinum	C - 4

Palladium	C - 5
Nickel	C - 7
Platinum	C - 10
Palladium	C - 11
D CryoStat	D - 1
CryoStat Operating Instructions	D - 1
Install Sample Tube for the CryoStat	D - 2
Rotameter Scale Readings	D - 3
Remove the CryoStat from the Analyzer	D - 4
Troubleshooting the CryoStat	D - 5
Preventive Maintenance for the CryoStat	D - 8
CryoStat Calibration	D - 9
E Data Logging	E - 1
Install the PuTTY Client	E - 1
Access the Data Log File	E - 3
Data File Column Descriptions	E - 3
Install Python Components	E - 4
Sample Python Code	E - 5
Chemical Adsorption Temperature Ramp Data	E - 7
F DFT Models	F - 1
Models Based on Statistical Thermodynamics	F - 1
Models Based on Classical Theories	F - 13
DFT Model References	F - 17
G Exported Data Example	G - 1
H Flowmeter Conversion Factors for Chemical Adsorption	H - 1
I Advanced Reports - Python Module	I - 1
Advanced Report Options	I - 1
Scripts	I - 3

Python Reports	I - 5
Acquire Basic Information	I - 8
Acquire Report Results	I - 11
Acquire Overlay Sample Data	I - 13
Enable the Use of Overlay Data	I - 16
MicModule Python Calls	I - 17
Tables	I - 17
Summary Reports	I - 18
Graphic Reports	I - 19
Get Primary Isotherm Data	I - 21
Get Overlay Isotherm Data	I - 22
Get Adsorptive Data for Each Sample	I - 24
Get Sample Information Item	I - 24
Get Report Results for Physical Adsorption	I - 25
Get Imported Pore Data	I - 26
Get Metal Composition for Chemical Adsorption	I - 27
J Vapor Adsorption Option	J - 1
Vapor Enclosure	J - 1
Temperature Controller	J - 2
Analysis Manifold	J - 2
Vapor Source	J - 2
Vapor Tube	J - 3
Vapor Analysis	J - 3
Specify Analysis Parameters	J - 3
Use a Metal Jacket on the Sample Tube	J - 6
Perform an Analysis at Ice Water Temperature	J - 7
Vapor Source Maintenance	J - 9
Clean the Vapor Source Tube	J - 9
Degas the Vapor Source Tube	J - 10
Replace Fuse in Temperature Controller	J - 12
K Worksheets	K - 1

Sample Data Worksheet for Gas Adsorption K - 2
Valve Test Worksheet for ASAP 2020 K - 3
Input Gas Worksheet K - 4

Index **Index - 1**

1 ANALYZER COMPONENTS FOR ASAP 2020

Parts and accessories can be found online at www.Micromeritics.com.

FRONT PANEL

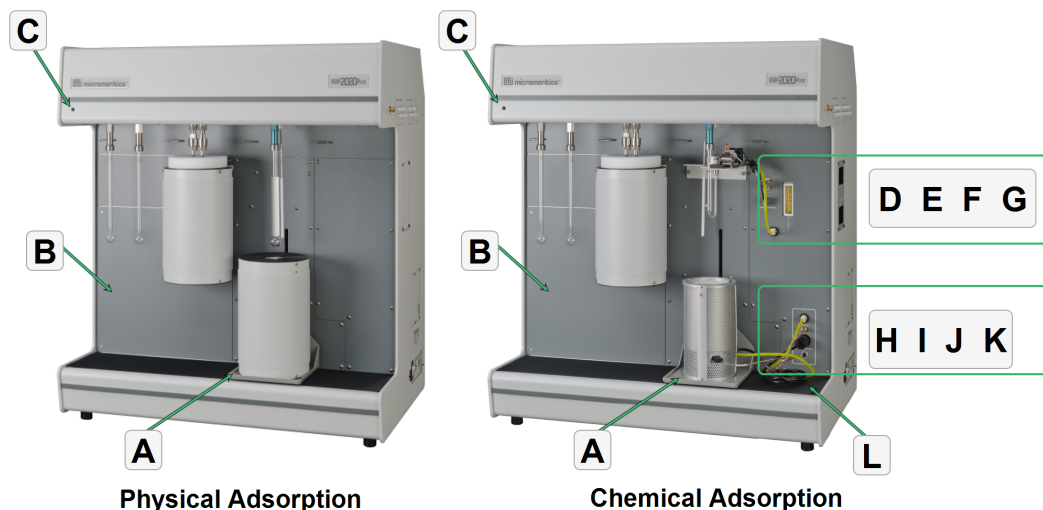

Front Panel Components

Component		Description
A	Elevator	Provides placement of the dewar or furnace.
B	Vacuum pump panel	Provides access to the vacuum pumps.
C	Power indicator light	Blinks when power is applied to the analyzer; illuminates when the analysis program is initiated and ready for operation.
D	Valve / Fan connector	Connects the sample exhaust valve and cooling fan. The cooling fan prevents overheating which could cause damage to the valve and/or O-rings. It is controlled by a thermostat and operates only when excessive heating occurs.
E	Sample thermocouple connector	Provides connection of the sample thermocouple.
F	Gas flow meter	Indicates the flow rate of gas passing through the sample tube.
G	Gas flow meter inlet	Connects the sample tube exhaust to the flow meter - measuring flow through the tube.
H	Furnace cooling gas connector	Provides connection of a compressed air supply for cooling the furnace.
I	Furnace thermocouple connector	Provides connection of the furnace thermocouple.

Front Panel Components (continued)

Component		Description
J	Furnace power connector	Provides connection of the furnace power cord.
K	Furnace circuit breaker	Protects the furnace in the event of a fault in the wiring. If the circuit breaker trips (pops out), contact a Micromeritics Service Representative.
L	High vacuum pump switch	Power switch for the high vacuum pump.

FRONT UNDERSIDE PANEL

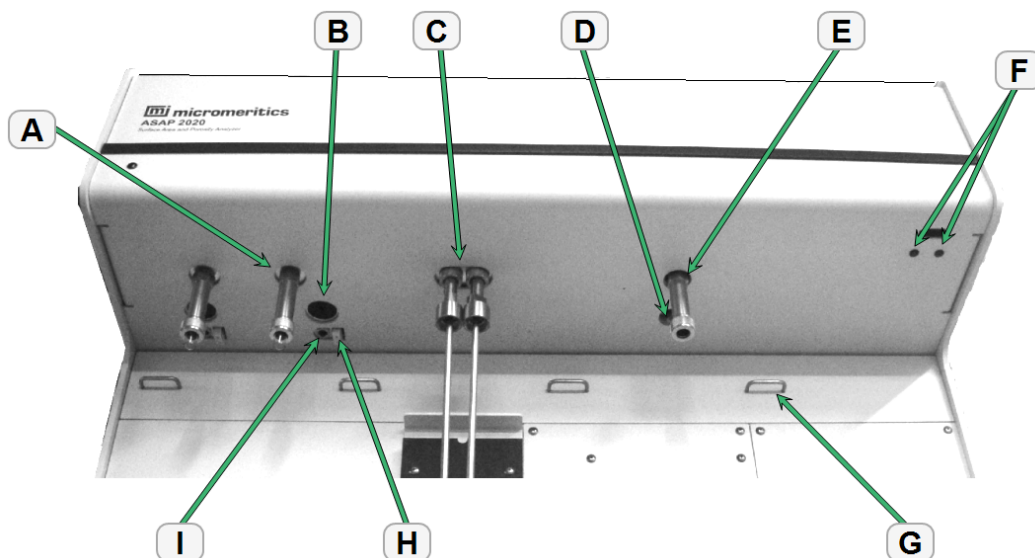

Front Underside Panel Components

Component	Description	
A	Degas ports	Two degas ports. Each degas port has a heating mantle connection.
B	Heating mantle power connector	Use to connect the heating mantle power cord.
C	Cold traps	(Optional) One cold trap is used for degassing and one for analysis.
D	P ₀ port	Use to install a P ₀ (saturation pressure) tube when performing analyses.
E	Sample port	Use to install the sample tube.
F	High vacuum pump indicators	Illuminate when the high-vacuum pumps are operating at normal speed. The left indicator is for degas operations and the right one for analysis.
G	Hangers	Four hangers for placement of protective shields.
H	Heating mantle thermocouple connector	For connecting a heating mantle thermocouple — one thermocouple connector for each degas port.
I	Heating mantle breaker	Protects the heating mantle circuitry in the event of a failure.

SIDE PANEL

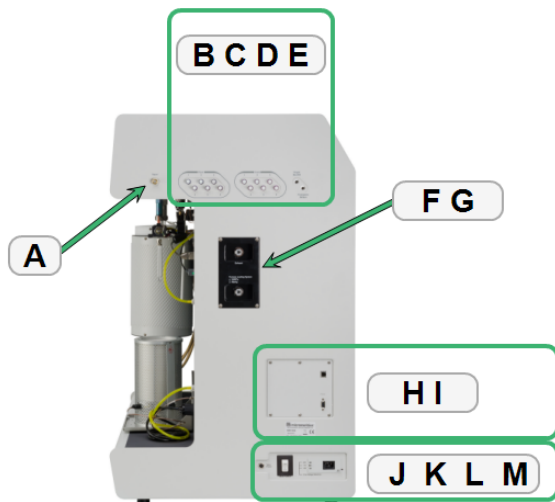

Side Panel Components

Component	Description
A	Vapor gas port For attaching the water vapor option or connecting a vapor gas.
B	Gas inlet ports P Provides connection for analysis gas for physical adsorption analyses.
C	Gas inlet ports C Provides connection for analysis gas for chemical adsorption analyses.
D	Degas backfill port Provides connection of a gas for degassing the sample.
E	Helium inlet port Provides connection of helium for measuring the free space.
F	Gasflow meter exhaust port Provides connection to a fume hood for safe venting of preparation gases.
G	Furnace cooling gas inlet port Admits the air supply for cooling the furnace.
H	Ethernet port Provides connection to the computer or Ethernet Switch.
I	RS232 port Not used.

Side Panel Components (continued)

Component		Description
J	Power connector	For connecting the instrument to the electrical supply.
K	Voltage selector switch	For setting the analyzer to the correct incoming AC line voltage.
L	Power switch	For powering the instrument ON and OFF.
M	Valve circuit breaker	Protects the valve circuitry in the event of a failure.

ANALYZER COMPONENTS FOR ASAP 2020A

FRONT COMPONENTS

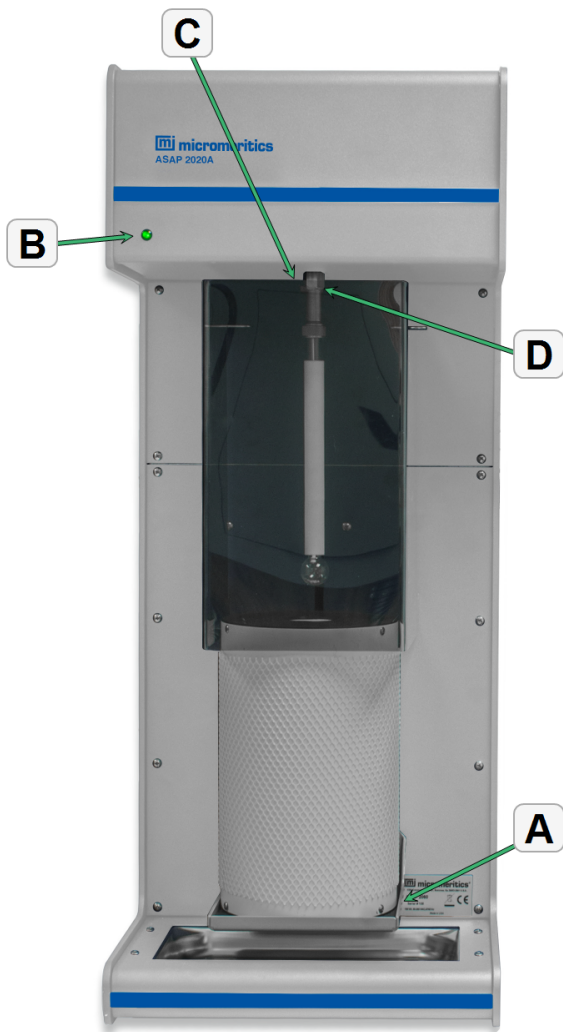

Front Panel Components

Component		Description
A	Elevator	Provides placement of the dewar.
B	Power indicator light	Blinks when power is applied to the analyzer; illuminates when the analysis program is initiated and ready for operation.
C	P _{sat} port	Use to measure saturation pressure.
D	Sample port	Use to attach a sample for analysis.

BACK PANEL COMPONENTS

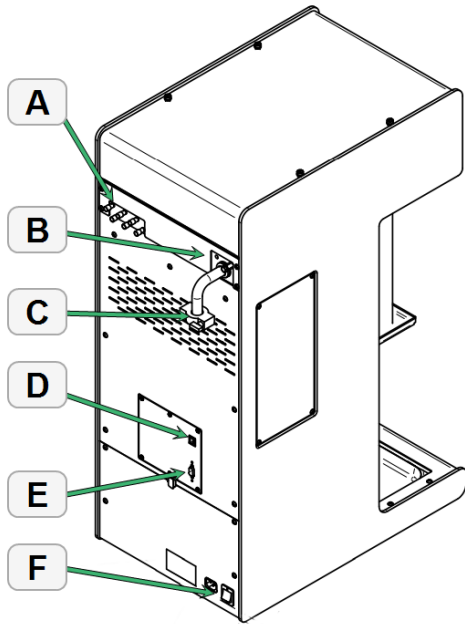

Back Panel Components

Component		Description
A	Gas Inlet ports	For attaching the analysis gases.
B	Helium Inlet port	Provides connection of helium for measuring the free space.
C	Vacuum Port	For attaching vacuum pumps.
D	Ethernet Port	Provides connection to the computer or Ethernet switch.
E	RS232 Port	Not used.
F	Power	Provides electrical cable connector. Includes ON/OFF switch.

EQUIPMENT OPTIONS AND UPGRADES

Parts and accessories can be found online at www.Micromeritics.com.

Equipment Option	Description
Chemical Adsorption Option	<p>Adds a stainless steel manifold with chemically resistant Kalrez seals to support analyses using aggressive gases or vapors as the adsorptive.</p> <p>Allows the chemical adsorption capability to be added to an ASAP 2020 analyzer. If a 10 torr transducer and a high-vacuum pump system do not exist on the current analyzer, an upgrade of the transducer and pump system will be required.</p>
Chiller Dewar	<p>A closed loop recirculating system that utilizes a high surface area copper coil to provide excellent heat transfer between the dewar and the recirculating liquids. Log in to your customer portal to access the Chiller Dewar Quick Start Guide (part number 025-42801-00).</p>
Cold Trap	<p>This kit contains all hardware and cold trap dewar needed for making the cold trap operational.</p>
CryoStat	<p>A closed-cycle CryoCooler based on the Gifford-McMahon (GM) refrigeration principle. It uses helium gas from a helium compressor to generate cryogenic temperatures. The cryostat eliminates the need for liquid nitrogen and can obtain temperatures below the 77 K of liquid nitrogen. The decibel rating of the CryoStat HC-4A Zephyr is 56 dBa at 1 meter.</p>
HiVac System	<p>Adds a 10 mmHg transducer and a high-vacuum pump to the standard physical adsorption system. This system provides low pressure capability and pressure measurement resolution required for analysis of low surface area materials using krypton as the adsorptive.</p>
Micropore Option	<p>Adds a 0.1 mmHg transducer and a high-vacuum pump. This system delivers accurate porosity data on pores between 0.35 and 3 nanometers and provides a comprehensive selection of micropore reports.</p>
Multigas to Micropore	<p>Allows a HiVac analyzer to be used for micropore analyses. This kit adds a 0.1 torr transducer to allow pressure measurements to be made more accurately in the sub 0.1 torr region.</p>
Vapor Adsorption Option	<p>Includes optional vapor accessories.</p>
2020A Analyzer	<p>Expansion unit for the ASAP 2020.</p>

GAS REQUIREMENTS

Compressed gases are required for analyses. Gas cylinders or an outlet from a central source should be located near the analyzer.

Appropriate two-stage regulators which have been leak-checked and specially cleaned are required. Pressure relief valves should be set to no more than 30 psig (200 kPag). All gases should be of a purity of 99.999% or better. Gas regulators can be ordered from Micromeritics. Parts and accessories can be found online at www.Micromeritics.com.

All analyzer types	Chemical adsorption units
(CGA 580) N ₂ 99.999% (CGA 580) He 99.999% (CGA 580) Kr * 99.995%	All gases listed to the left and: (CGA 350) H ₂ 99.999% (CGA 350) CO 99.990%
* Krypton needed for krypton units only	

SPECIFICATIONS FOR ASAP 2020 AND 2020A

Specification	Description
Cryogen System	
Analysis Time	Unlimited. Cryogen dewars may be refilled without affecting the accuracy of results.
Capacity	3 liter dewar, which typically provides up to 72 hours of unattended analysis.
Special Features	Isothermal Jackets maintain cryogen level constant on sample tube and P ₀ tube during analysis while evaporation of cryogen occurs.
Degas System (optional)	
Backfill Gas	User-selectable, typically helium or nitrogen.
Pressure Range	0 to 950 mmHg. Accuracy: 1% best fit straight line.
Temperature Range	Ambient to 450 °C, 1 °C increments. Accuracy: Deviation less than ±10 °C of set point at thermocouple.
Electrical	
Voltage	100, 115, 230 VAC ±10%
Frequency	50 to 60 Hz
Power	700 VA, operating
Environment	
Temperature	10 to 30 °C, operating -10 to 55 °C, storing or shipping
Humidity	20 to 80% relative, noncondensing
Gases	
Argon, carbon dioxide, nitrogen, krypton (multigas system), and other suitable gases.	
Manifold Temperature Transducer	
Type	Platinum resistance device (RTD)
Accuracy	±0.02 °C

Specification	Description
Physical (ASAP 2020)	
Height	99 cm (39 in.)
Width	85 cm (33.5 in.)
Depth	61 cm (24 in.)
Weight	115 kg (250 lbs.)
Physical (optional ASAP 2020A)	
Height	94.5 cm (37.2 in.)
Width	38.1 cm (15.0 in.)
Depth (chassis)	59.0 cm (23.2 in.)
Depth (with vacuum tube)	68.1 cm (26.8 in.)
Weight	68 kg (150 lbs)
Pressure Measurement	
Accuracy (Analysis system only) — Includes nonlinearity, hysteresis, and nonrepeatability. Transducer manufacturer's specifications. All within 0.15% of reading.	
Range	0 to 950 mmHg
Resolution	
1000 mmHg Transducer	0.001 mmHg (Analysis system and P ₀ system) 1 mmHg (Degas system)
10 mmHg Transducer <i>(high-vacuum systems)</i>	0.00001 mmHg
1 mmHg Transducer <i>Micropore systems (optional for high stability)</i>	0.000001 mmHg
0.1 mmHg Transducer <i>Micropore systems with 0.1 mmHg transducer (optional for high stability)</i>	0.0000001 mmHg
Sample Size	
Sample tubes are available for various size pellets, cores, and powders. Sample tube stems are normally 1.27 cm (1/2 in.) OD with 9 cc bulbs. Also available are 0.635 cm (1/4 in.) or 0.953 cm (3/8 in.) OD with 9 cc bulbs. A 22-mm (0.87 in.) ID, 25 mm (1.0 in.) OD sample tube kit is also available. Special tubes can be designed to accommodate unusual samples. If other sizes are required, contact your local Micromeritics representative.	

Specification	Description
System Capacity	
Analysis	1 sample port and 1 saturation pressure tube (2 each with the optional ASAP 2020A).
Sample Preparation	2 degas ports (ASAP 2020). The optional ASAP 2020A has no degas ports.
Total Operating Capacity	Up to four complete analysis units can be controlled independently by one computer.
Vacuum System	
Vacuum Pump	Mechanical, two-stage, for analysis; optional for degas. Ultimate vacuum 5×10^{-3} mmHg. Dry pumps available for systems equipped with optional high-vacuum pump.
High-vacuum Pump	(If installed.) Less than 3.8×10^{-9} mmHg, as measured by pump manufacturer according to Pneurop Standard 5608.
Computer Requirements	
<ul style="list-style-type: none"> • Operating System. Windows 7 Professional or higher operating system is recommended for the best user experience. • Desktop Installation Required. The application should not be installed on a network drive with shared access. Multiple users cannot operate the application at the same time. • 10 Base T or 100 Base T Ethernet Port. If the computer is to be connected to a network, two Ethernet ports are required. If more than one Ethernet based unit is connected to the same computer (or if a Smart VacPrep or ASAP 2020A is purchased), an Ethernet switch will also be required. • Read / Write Permissions. All users of the application will need Read/Write permission to all directories and subdirectories where the application is installed. • Drives. USB port. 	
<i>In keeping with a policy of ongoing product improvement, specifications are subject to change without notice.</i>	

2 ABOUT THE SOFTWARE

The analyzer allows other computer programs to run while an automatic operation is in progress. The *Help* menu provides access to the online operator manual.

Report options can be specified when creating the sample file. When running an analysis, data gathered during the analysis process are compiled into the predefined reports. Reports can also be defined and generated after an analysis has been run. Each selected report is displayed on its own tab and reflects data collected during the analysis.

The MicroActive feature offers a Windows interface with an easy way to collect, organize, archive, reduce raw data, and store sample files for later use. Scalable and editable graphs, and copy and paste graphics, are easily generated. Customized reports can be viewed on a computer monitor, printed, or exported for use in other programs.

In addition to customizable standard reports, user defined calculations and reports can be created through the Advanced reports feature (using Python).

Data can be manipulated and displayed interactively using MicroActive reports.

SOFTWARE SETUP



If the computer is to be connected to a network, a second Ethernet port on the computer must be used for that purpose.

The *Setup* program is located on the installation media and is used to reinstall the software and make analyzer changes — such as adding, moving, or removing a unit, etc.



If the IP address needs to be changed on the computer connected to the analyzer, refer to the computer's operating system manual or the internet for instructions. The IP address for the computer and the IP address specified in the setup program must match. The IP address must be 192.168.77.100.

MENU STRUCTURE

All program functions use standard Windows menu functionality. The title bar contains a *Unit [N]*. If multiple analyzers are installed, ensure the appropriate unit is selected before continuing.

Main Menu Bar Options

Option	Description
File	Use to manage files used by the application — such as sample files, analysis conditions files, report options files, etc.
Unit [n]	Use to perform analyses, calibrations, and other analyzer operations. <i>Unit [n]</i> displays on the menu bar for each analyzer attached to the computer.
Smart VacPrep	(If installed.) Use to access the menu for each installed Smart VacPrep.
Reports	Use to run reports and view the results.
Options	Use to edit the default method, specify system configuration, specify units, and change presentation options.
Window	Use to manage open windows and display a list of open windows. A checkmark appears to the left of the active window.
Help	Provides access to the online operator manual, the Micromeritics web page, the analyzer web page, and information about the application.

COMMON FIELDS AND BUTTONS

The fields and buttons in the following table are located in multiple windows throughout the analyzer application and have the same description or function. Fields and button descriptions not listed in this table are found in tables in their respective sections.

Common Fields and Buttons

Field or Button	Description
Add	Add an item to the list.
Add Log Entry	Use to enter information to appear in the sample log report that cannot be recorded automatically through the application. Click the button again to enter multiple log entries.
Append	Use to insert one row at the end of a table.
Autoscale	When enabled on report parameters windows, allows the x- and y-axes to be scaled automatically. <i>Autoscale</i> means that the x- and y-ranges will be set so that all the data is shown. If <i>Autoscale</i> is not selected, the entered range is used.
Axis Range	On report parameters windows, the <i>From / To</i> fields are enabled when <i>Autoscale</i> options are not selected. Enter the starting and ending values for the x- and/or y-axes.
Bar Code (<i>default field label name</i>)	Enter bar code reader information if a bar code reader is connected to the computer's USB port. If a bar code reader is not used, this alphanumeric field can be used to enter additional information about the sample, such as a sample lot number, sample ID, etc. This field label may have been renamed or may not display if modified in Options > Default Methods .
Browse	Searches for a file.
Cancel	Discards any changes or cancels the current process.
Clear	Use to clear the table entries and display only one default value.
Close	Closes the active window.
Close All	Closes all active windows. If changes were made and not yet saved, a prompt displays for each changed file providing the option to save the file.

Common Fields and Buttons (continued)

Field or Button	Description
Comments	Enter comments about the sample or analysis. Comments display in the report header.
Copies	Select the number of copies to print. This field is only enabled when <i>Print</i> is selected.
Delete	When working with pressure tables and pressures, Delete removes the selected information.
Destination	Select the report destination.
Edit	When working with report parameters, highlight the item in the <i>Selected Reports</i> list box and click Edit to modify the report details.
Exit	Exits the application. If a file is open with unsaved changes, a prompt displays providing the option to save the changes and exit or to exit the application without saving the changes.
Export	Exports data in a sample file as a .REP, .TXT, or .XLS file. When saved to a file, the data can be imported into other applications.
File	Select the destination directory. Enter a new file name in the <i>File name</i> field, or accept the default. Select to save the file as a report system (.REP), a spreadsheet (.XLS), a portable document format (.PDF), or an ASCII text (.TXT) file format.
File name	Select a file name from the list shown or enter a file name. If the required file type is not shown, select the type of file from the list.
From / To	When working with report parameters windows, enter the <i>From</i> and <i>To</i> range for x- and/or y-axes.
Insert	Use to insert one row above the selected row in the table.
List	Creates a list of sample or other type files. The list will contain file name, date / time the file was created or last edited, file identification, and file status.
Name	The <i>Name</i> column is a list of files in the selected directory or library.
Next	Click to move to the next window or next step.
OK	Saves and closes the active window.
Open	Opens the selected file. Alternatively, double click the file name in the <i>Name</i> column to open the file.
Prev	Click to move to the previous window.
Preview	Previews predefined reports. Click the tabs at the top of the window to preview each selected report. When an analysis has not been run on a sample, this button is disabled.

Common Fields and Buttons (continued)

Field or Button	Description
Print	Sends the report to the selected destination (screen, printer, or file).
Remove	Remove the selected file or files from the list.
Replace	Click to select another file where the values will replace the current file's values.
Replace All	Click to select another .SMP file where the values will replace all values for the active sample file. The original file will remain unchanged.
Report	Click to display a window to specify report output options.
Save	Saves changes to the active window.
Save As	Saves a file in the active window under a different file name.
Start	Starts the report, test, analysis, or operation.
Start Date	Displays a calendar to select the start date for the report.
View	<p>Operation. Use to display the data from the current analysis.</p> <p>Instrument Log. Use to display recent analyses, calibrations, errors, or messages.</p> <p>Instrument Schematic. Use to display a schematic of the analyzer system.</p>

FILE STATUS, DESCRIPTION, EXTENSION, AND LOCATION

In the *File Selector* window, the *Mic Description* column and the *Mic Status* column display file description and file status. The *File Selector* incorporates standard Windows features for resizing windows, reordering and repositioning columns, and right clicking an entry to display a menu of standard Windows functions.

File Status

File Status	Description
Analyzing	Sample files that are currently being used for analysis.
Complete	Sample files used in an analysis that has been completed.
Entered	Sample files containing manually entered data.
No Analysis	Sample files which have not been used to perform an analysis.

File Type, Extension, and Location

File Type	File Name Extension	Default Location
Alpha-s Curve *	.ALS	Param directory
Adsorptive Properties	.ADP	Param directory
Analysis Conditions	.ANC	Param directory
Degas Conditions	.DEG	Param directory
Heat of Adsorption Report	.HOA	Param directory
Methods	.MTH	Param directory
Report Options	.RPO	Param directory
Sample Information	.SMP	Data directory
Sample Tube Properties	.STB	Param directory
Thickness Curve **	.THK	Param directory

* **Alpha-S Curve file.** Saves the relative pressures and resulting quantities adsorbed as an ASCII text file. These data are derived by dividing the isotherm by the quantity adsorbed at 0.4 relative pressure.

** **Thickness Curve file.** Saves the relative pressures and corresponding thicknesses as an ASCII text file. These data are derived by dividing the condensed volume of adsorptive by the selected surface area. The density conversion factor in the adsorptive properties file is used to convert quantity adsorbed to volume of condensed adsorptive.

File types available when printing or exporting reports:	
Portable document format	.PDF
Report	.REP
Spreadsheet	.XLS
Unicode	.TXT
Extensible markup language	.XML

KEYBOARD SHORTCUTS

Shortcut keys can be used to activate some menu commands. Shortcut keys or key combinations (when applicable) are listed to the right of the menu item.

Certain menus or functions can also be accessed using the **Alt** key plus the underlined letter in the menu command. For example:

- to access the *File* menu, press **Alt + F**, then press the underlined letter on the submenu
- **Alt + F** opens the *File* menu, then press **O** to access the *File Selector*



If the underscore does not display beneath the letter on the menu or window, press the **Alt** key on the keyboard.

Keyboard Shortcuts

Field or Button	Description
Alt + [Unit n]	Opens the <i>Unit [n]</i> menu.
Alt + F	Opens the <i>File</i> menu.
Alt + F4	Exits the program. If files are open with unsaved changes, a prompt to save changes displays.
Alt + H	Opens the <i>Help</i> menu.
Alt + I	Opens the <i>Options</i> menu.
Alt + R	Opens the <i>Reports</i> menu.
Alt + V	Opens the <i>Smart VacPrep</i> menu.
Alt + W	Opens the <i>Window</i> menu.
Shift + F9	Opens the shortcut menu of either the selected component on the analyzer schematic when manual control is enabled or onscreen reports.
Ctrl + N	Opens a new sample file.
Ctrl + O	Opens the <i>File Selector</i> window.
Ctrl + P	Opens the <i>File Selector</i> to start a report from a selected .SMP file.
Ctrl + S	Saves the open file.
F1	Opens the online help operator manual.
F2	Opens the <i>File Selector</i> window.
F3	When in the <i>File Selector</i> window, opens the file search box.
F4	When in the <i>File Selector</i> window, opens the address bar.

Keyboard Shortcuts (continued)

Field or Button	Description
F6	Cascades open windows.
F7	Tiles all open application windows.
F8	Opens the <i>File Selector</i> to start a report from a selected .SMP file.
F9	Closes all open reports.
F10	Opens the <i>Heat of Adsorption</i> window.

OPTION PRESENTATION

Options > Option Presentation

Use to change the way sample files and parameter files display: *Advanced*, *Basic*, or *Restricted*. Each display option shows sample information and options differently.

Option Presentation Display

Presentation Display	Description
Advanced	Displays all parts of sample and parameter files. Navigate to parameter windows by selecting the tabs across the top of the window.
Basic	Displays sample information in a single window. This display option is used after the parameter files have been created. The previously entered or default parameter files are then accessible using drop-down lists.
Restricted	Displays the sample file in a single window similar to the <i>Basic</i> display option with certain functions disabled. A password is set when the <i>Restricted</i> option is selected. That same password must be entered to change to the <i>Basic</i> or <i>Advanced</i> display option. This display type is typically used in laboratories where analysis conditions must remain constant — such as the pharmaceutical industry. The <i>Advanced</i> option is not available at the bottom of the window when using the <i>Restricted</i> display option.
Show Splash Screen	Enables (or disables) the splash screen upon application startup.
Show Degas Conditions 	When enabled, displays the <i>Degas Conditions</i> tab when using <i>Advanced</i> option presentation and the Degas Conditions drop-down list when using <i>Basic</i> or <i>Restricted</i> option presentation. This option may be deselected to hide the <i>Degas Conditions</i> tab if not using a SmartPrep or Smart VacPrep.



Specify or change the default option presentation by selecting **Options > Option Presentation**, or select *Basic* or *Advanced* from the drop-down list at the bottom of the window.

The following examples show the same sample file in *Advanced* and *Basic* display. *Basic* and *Restricted* displays will look the same.

**Advanced
option presentation**

**Basic / Restricted
option presentation**



A sample file must be created for each analysis. The file can be created prior to or at the time of analysis. The sample file identifies the sample, guides the analysis, and specifies report options.

LIBRARIES

Options > Manage Libraries



This feature is available only to Windows 7 and higher operating systems.

The library provides an easy way to locate and open specific analyzer files. Libraries are located within the *File Selector* window and can be viewed only within the application.

The library gathers sample and parameter files that are stored in multiple locations — such as folders on a C: drive, a network location, a connected external hard drive, or a connected USB flash drive — providing access to all files. Even though libraries do not store actual sample and parameter files, folders can be added or removed within each library.

One library can include up to 50 folders. Other items — such as saved searches and search connectors — cannot be included.

When removing a folder from a library, the folder and its contents are not deleted from the original file storage location. However, when deleting files or folders from within a library, they are deleted from their original file storage location.

METHODS

Options > Default Method

File > Open > [.MTH File]

A *Method* determines the default sample identification format and sequence number. A *Method* is a template of specifications that go into a newly created sample file. It allows for the definition of complete sets of parameters for each type of sample commonly analyzed, so that only a single selection is required for each new sample file created.

The *Method* drop-down list displays only those methods applicable to the open sample file type.

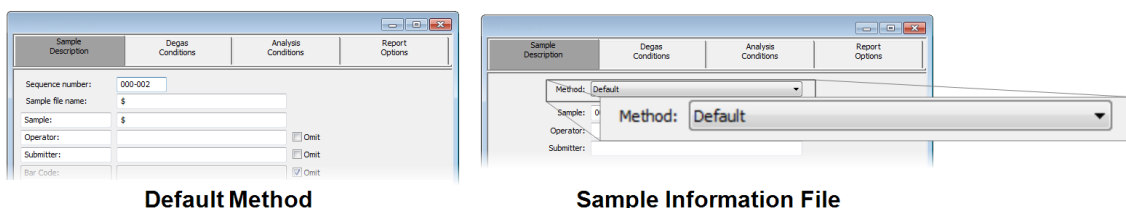

Default Methods

Field or Button	Description
Sequence Number [text box]	Specify a default numeric string to be used as a prefix in the <i>Sample</i> field when a new sample file is created. This number increments with each sample file created.
Sample file name [text box]	Enter a format for the sample identification. The entry in this field becomes a part of the saved sample file name. Include the \$ symbol to have the sample file number included as part of the identification.
Sample Operator Submitter Bar Code [text box]	These field labels may be renamed and the new label becomes a part of all new sample files.

Default Method Files

Method Selected	Default File Modified
Physical Adsorption	2020.SMP
Chemical Adsorption	2020Chemi.SMP

CREATE A METHOD

File > New Method

1. On the *Create a Method* window, select the *Sample Morphology* to be used and the *Material Type and Characterization*, then click **Next**.

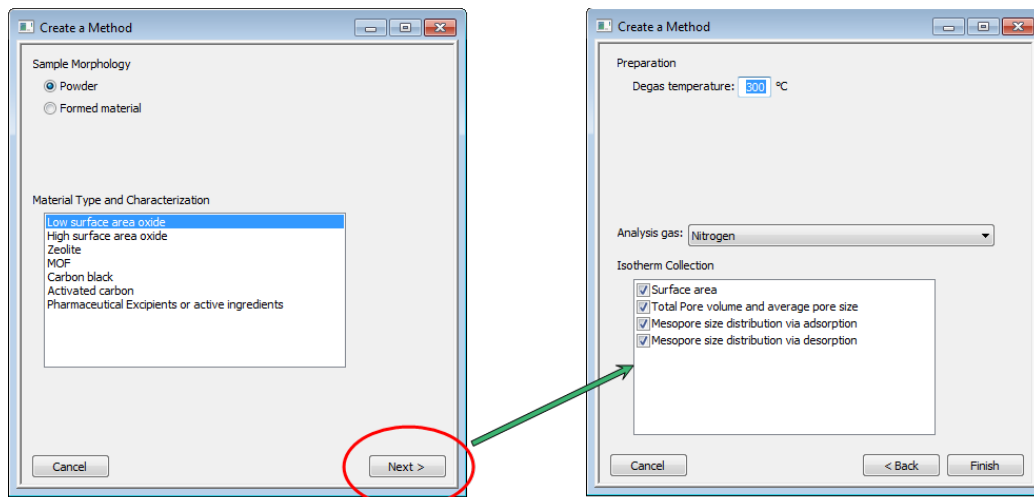

2. Enter a *Degas temperature*, then select an *Analysis gas* from the drop-down list.
3. Select the applicable isotherm collections. The *Isotherm Collection* options determine the pressures of the data points measured in the analysis. Click **Finish**.
4. See [Methods on the previous page](#) to complete the form.

Options > Default Method

See [Methods on the previous page](#) to complete the form.

CONFIGURE THE ANALYZER

UNIT CONFIGURATION

Unit [n] > Unit Configuration > Gas

Use to display hardware / software configurations, calibrations, and gas selections of the connected analyzer. The analyzer has gas inlets for up to six analysis gases for physical adsorption and 12 for chemical adsorption.

The gases connected to the inlets must be specified in the analysis program. If the gas is changed on one of the inlets, the same change must be made on the *Unit Configuration* window.

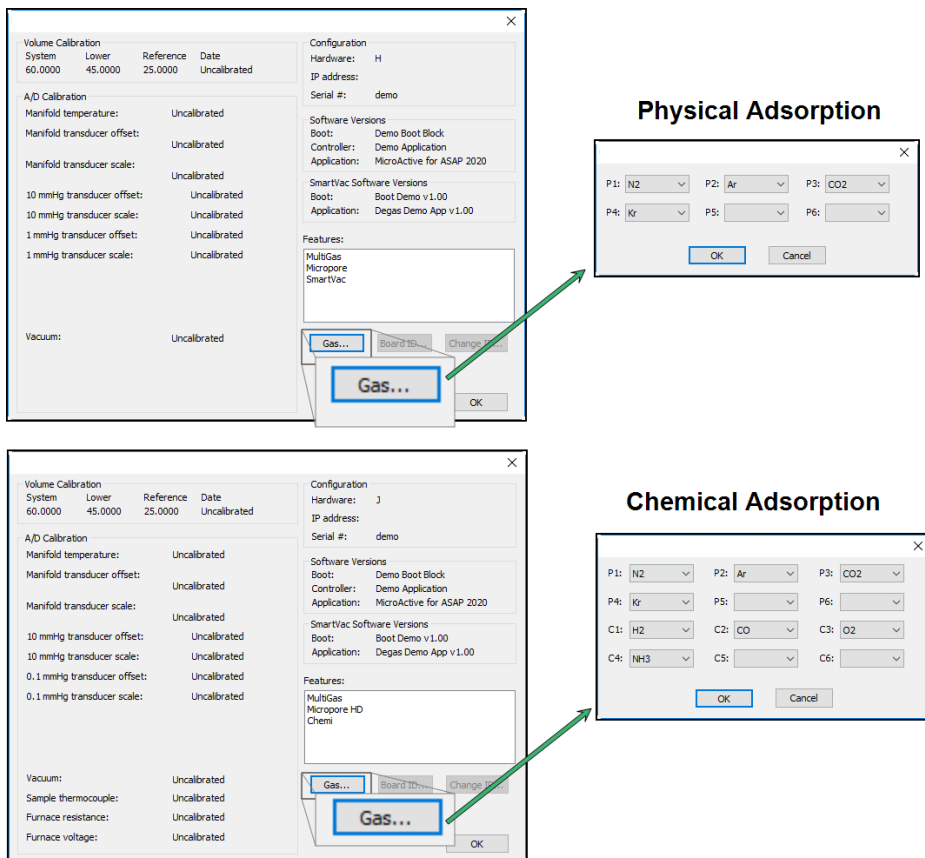

Unit Configuration

Field or Button	Description
Calibrations [group box]	Displays calibration information for analyzer components.

Unit Configuration (continued)

Field or Button	Description
Configuration <i>[group box]</i>	<p>Displays the IP address used by the analysis program, serial number, and type of analyzer.</p> <p>IP address. Displays the IP address of the analyzer.</p> <p>Change IP <i>[button]</i>. Click to display the <i>Unit IP Setup</i> window. Use to change the IP address and subnet mask assigned during installation. Do not edit these fields unless instructed by a Micromeritics Service Representative.</p> <p>Board ID <i>[button]</i>. Click to display information from the electronic circuit boards in the analyzer. These parameters cannot be edited.</p>
Gas <i>[button]</i>	Displays ports for gas selections.
Software Versions <i>[group box]</i>	Displays the software versions of the MIC BIOS, controller, and analysis program.

UNIT SELECTIONS

Options > Units

Use to specify how data should appear on the application windows and reports. This menu option is not available if using *Restricted* option presentation in a standard installation environment.

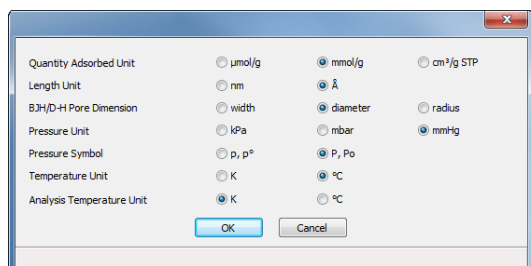

Physical Adsorption

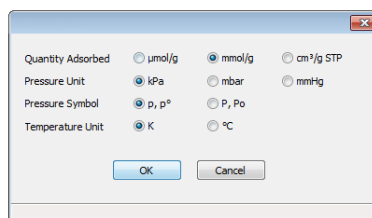

Chemical Adsorption

INSTRUMENT STATUS

SHOW INSTRUMENT LOG

Unit [n] > Show Instrument Log

Use to display a log of recent analyses, calibrations, errors, or messages.

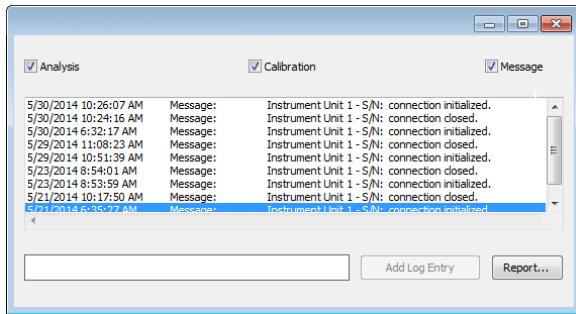

Instrument Log

Field	Description
Add Log Entry [button]	Use to enter information to appear in the sample log report that cannot be recorded automatically through the application. Click the button again to enter multiple log entries.
Analysis/ Calibration/ Message [checkbox]	Select the logs to display.
Report [button]	Click to select print destination and report start date.
 <p>For fields and buttons not listed in this table, see Common Fields and Buttons on page 2 - 3.</p>	

SHOW INSTRUMENT SCHEMATIC

Unit [n] > Show Instrument Schematic

Use to display an analyzer schematic. To operate the valves and elevator from this window, manual control must be enabled (**Unit [n] > Enable Manual Control**).

Physical Adsorption

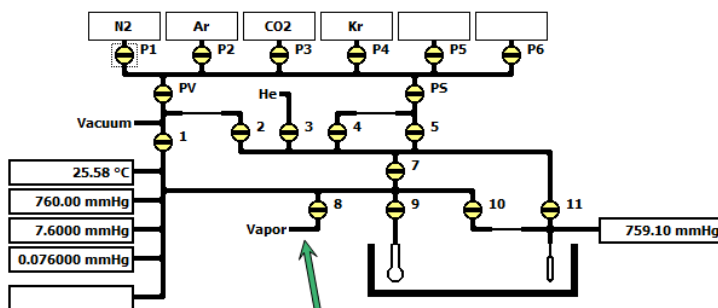

NOTE: Vapor (port 8) not applicable to the 2020A

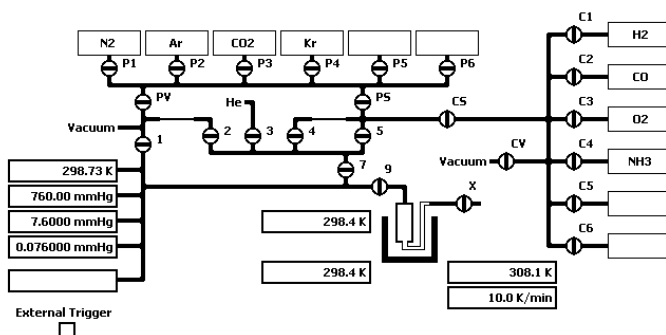

Chemical Adsorption



Analyzer Schematic Icon Table

Icon or Symbol	Description
	Open Valve. Green indicates an open valve.
	Closed Valve. Yellow indicates a closed valve. When manual control is disabled, closed valves appear white.
	Servo Valve. Closed.
	Servo Valve. Open.

Analyzer Schematic Icon Table (continued)



Icon or Symbol	Description
	Elevator.
	C Sample Tube and Furnace Elevator. The sample tube icon is white when the sample and furnace temperatures are 50 °C or lower. If either the sample or furnace temperature exceeds 50 °C, the sample tube icon turns orange. Temperature readings and ramp rate are displayed below and to the left of the icon. The furnace icon resides on the elevator.
	P Sample Tube. Cannot be manually controlled.

Analysis Valve Descriptions

Valve	Description
1	Unrestricted vacuum
2	Restricted vacuum
3	Helium inlet port valve
4	Restricted analysis gas
5	Unrestricted analysis gas
7	Lower manifold isolation
8	Vapor inlet port (not applicable to the 2020A)
9	Sample port
10	Restricted Psat tube port
11	Unrestricted Psat tube port
P1 through P6	Gas inlet port valves
PS	Supply valve for physical adsorption gases
PV	Vacuum valve for physical adsorption gases

Instrument Schematic Shortcut Menus

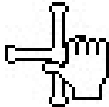
Schematic Shortcuts

Schematic Shortcut Icon	Description
Valve options 	<p>Close. Closes the selected valve.</p> <p>Open. Opens the selected valve.</p> <p>Pulse. Use to quickly turn the valve on and off allowing the operation to proceed in small increments.</p>
Elevator options 	<p>Raise. Select <i>Raise</i> to raise the elevator. When it is moving, press the keyboard space bar to stop the movement (or right click and select <i>Stop</i> from the menu).</p> <p>Lower. Select <i>Lower</i> and press the keyboard space bar to lower the elevator.</p> <p>Stop. Stops the elevator from moving.</p>
Temperature control options 	<p>On. Enables the temperature control.</p> <p>Off. Disables the temperature control.</p> <p>Set. Select to set the following:</p> <ul style="list-style-type: none"> • Enable or disable temperature control • Control sample temperature • Control furnace temperature • Cool the sample to less than 50 °C • Set heater power percent

SHOW STATUS

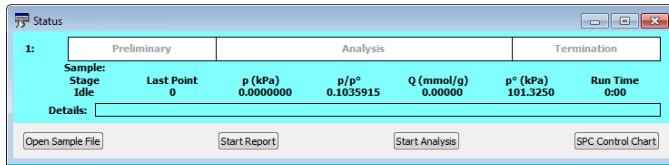

Physical Adsorption

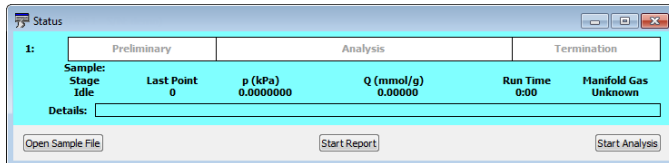

Chemical Adsorption

If multiple units are attached to the computer, select *Show Status* on each *Unit [n]* menu. The status for all units display.

EXPORT FILES

File > Export



See also:

[Exported Data Example on page G - 1](#)

Provides the option to print the contents of one or more sample or parameter files to either the screen, a printer, or to a file. Data can be exported as a .PDF, .REP, .TXT, .XML, or .XLS file format. The type of data to include or exclude can be selected during the export process. When exported to a file, the data can be imported into other applications that read these file formats.

LIST FILES

File > List

Provides the option to create a list of sample file information —such as file name, date, time the file was created or last edited, file identification, and file status.

Select one or more files from the file selector, then click [List](#).

File Listing					
No.	File Name	Date	Time	File Identification	Status
1	d-4cn2ex.smp	11/4/2018	10:12:01 AM	D-4 Carbon (example)	Complete
2	KRMCM80.SMP	11/4/2018	10:12:01 AM	MCM41 80 K (Kr) (heat of adsorption)	Complete
3	KRMCM90.SMP	11/4/2018	10:12:01 AM	MCM41 90 K (Kr) (heat of adsorption)	Complete
4	KRMCM102.SMP	11/4/2018	10:12:01 AM	MCM41 102 K (Kr) (heat of adsorption)	Complete
5	KRMCM110.SMP	11/4/2018	10:12:01 AM	MCM41 110 K (Kr) (heat of adsorption)	Complete
6	KRMCM120.SMP	11/4/2018	10:12:01 AM	MCM41 120 K (Kr) (heat of adsorption)	Complete
7	KRMCM130.SMP	11/4/2018	10:12:01 AM	MCM41 130 K (Kr) (heat of adsorption)	Complete
8	n2blank.smp	11/4/2018	10:12:02 AM	Blank Tube Test	No Analysis
9	refchmbr.smp	11/4/2018	10:12:02 AM	Reference Chamber Run	No Analysis
10	sial_ref.smp	11/4/2018	10:12:02 AM	Silica Alumina Reference Material	No Analysis

SOFTWARE UNINSTALL

When the software is uninstalled using *uninstall.exe*, only the files required to run the application are removed. Parameter files, sample files, reports, calibration files, and data files are not removed.

To uninstall the software, double click the *uninstall.exe* file located in the software installation directory, then follow the prompts.

SOFTWARE UPDATES

Log in to your [customer portal](#) to access and download the latest analyzer software version.

When performing a software update, existing data files are not overwritten. There are three types of subsequent installation:

- a later version than the current installation
- the same version as the current installation
- an earlier version than the current installation

Insert the setup media into the media drive. The setup program starts automatically. If the program does not start automatically, navigate to the installation media drive, locate and double click the *setup.exe* file.

3 SAMPLE FILES

Sample files include the information required by the analyzer to perform analyses and collect data. A sample file identifies the sample, guides the analysis, and specifies report options and may be displayed in either *Advanced*, *Basic*, or *Restricted* presentation display mode.

A sample file consists of parameter sets; however, parameter sets can also stand alone. A sample file may be created either prior to or at the time of analysis.

Parameter files allow for repeated use of parameter sets. For example — if the same analysis conditions exist for multiple analyses, an *Analysis Conditions* file containing the recurring conditions can be created. When the sample file is created, the *Analysis Conditions* file can be selected for the analysis conditions. Once it becomes part of the new sample file, the new file can be edited as needed without affecting the original *Analysis Conditions* file.

The analysis application contains a default method. A method is a template for sample files that contains the parameters to be used for an analysis. When a new sample file is created, all the parameters are filled with the values in the default method.



Specify or change the default option presentation by selecting **Options > Option Presentation**, or select *Basic* or *Advanced* from the drop-down list at the bottom of the window.

CREATE SAMPLE FILES

Options > Option Presentation > Show Degas Conditions 

File > New Sample > [.SMP File]

File > Open > [.SMP File]

Each analysis must be linked with a sample file before the analysis can proceed. A sample file can consist of parameter files; however, parameter files can also stand alone.

Specify or change the default display option by selecting **Options > Option Presentation** or select *Basic* or *Advanced* from the drop-down list at the bottom of the window.

Sample files created in *Basic* option presentation must selected from parameter files created in *Advanced* option presentation.

The values specified in the parameter portions of the default method are the defaults for new sample files. To navigate from one set of parameters to another, select the parameter tab across the top of the window.

Sample Tube parameters are edited on the *Sample Description* tab.



The *Degas Conditions* tab displays only if enabled in **Options > Option Presentation > Show Degas Conditions**.

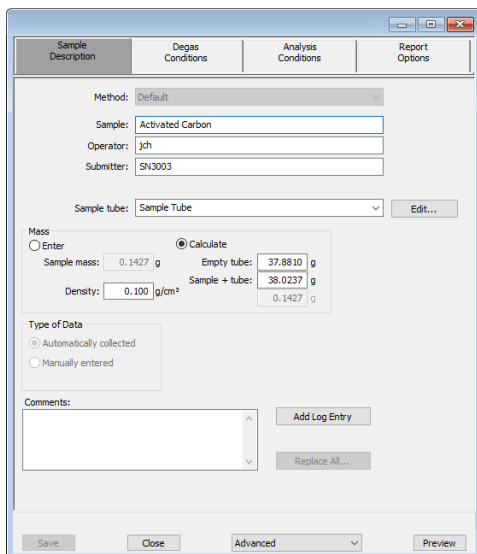

Example of tabbed file editor in
Advanced option presentation

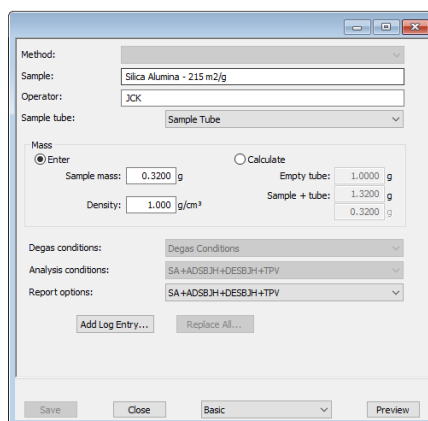

Example of file editor in
Basic option presentation





A bar code reader may be used to enter text into many of the fields on the *Sample Description* window. Use a mouse to click in the field first where information is to be entered then scan the bar code with the bar code reader.

Sample Files

Field or Button	Description
Active Metals [button] 	Displays a list of active metals.
Add Log Entry [button]	Use to enter information to appear in the sample log report that cannot be recorded automatically through the application. Click the button again to enter multiple log entries.
Bar Code	Enter bar code reader information if a bar code reader is connected to the computer's USB port. If a bar code reader is not used, this alphanumeric field can be used to enter additional information about the sample, such as a sample lot number, sample ID, etc. This field label may have been renamed or may not display if modified in Options > Default Methods .
Comments [text box]	Enter comments about the sample or analysis. Comments display in the report header.
Mass [group box]	<p>If mass = 1, the reported surface area equals the total surface area but it is always shown as m²/g. If an accurate mass is entered, the reported surface area is normalized per gram of sample. Choose whether to enter mass manually or have the system automatically calculate mass. Enter a value for sample mass. Mass can be changed any time before, during, or after analysis.</p> <p>Enter. Enables the <i>Sample mass</i> field. Enter a value for the sample mass.</p> <p>Calculate. Enables the <i>Empty tube</i> and <i>Sample + tube</i> fields. Enter the values necessary to calculate the sample mass. Equation used to calculate sample mass:</p> $Mass_{sample} = Mass_{sample+tube} - Mass_{tube}$ <p>Density. Value is used for the calculated free space method only. Use 0.000 for a blank analysis.</p>
Method [drop-down box]	Select a method from the drop-down list.
Operator [text box]	Enter operator identification information. This field label may have been renamed or may not display if modified in Options > Default Methods .

Sample Files (continued)

Field or Button	Description
Sample [text box]	Enter a sample description. This field label may have been renamed or may not display if modified in Options > Default Methods .
Sample Tube [drop-down box] 	Select a sample tube file from the drop-down list, or click Edit to modify or create a new sample tube file.
Submitter [text box]	Enter submitter identification information. This field label may have been renamed or may not display if modified in Options > Default Methods .
Type of Data [group box]	<p>Automatically collected. Select if the type of data will be automatically collected by the system while an analysis is running.</p> <p>Manually entered. Use to enter data manually that was collected from another source. If <i>Manually entered</i> is selected, the Isotherm Report becomes available in the <i>Basic/Advanced</i> drop-down list for pasting or importing data into the file.</p> <p>See Manually Enter Data on the facing page.</p>
User Parameters [group box]	These fields are primarily used for the SPC (Statistical Process Control) reporting to specify sample characteristics or its manufacturing process but may be used for other data by entering specific analysis conditions or sample criteria. The entered parameters display on the <i>SPC Report</i> . Some fields may not display (or may have a different field label) if modified in the method from which the sample file was created, either through Options > Default Method or File > Open > Method . See SPC Report for Physical Adsorption on page 7 - 4 .
	<p>For fields and buttons not listed in this table, see Common Fields and Buttons on page 2 - 3.</p>

OPEN A SAMPLE FILE

File > Open > [.SMP File]



When working with an existing sample file, consider making a copy of the sample file to maintain the original configuration options.

File Type	File Status	Displays
Physical Adsorption or Chemical Adsorption	Preparing Prepared No Analysis	Tabbed file editor
	Complete Analyzing Entered	MicroActive report window

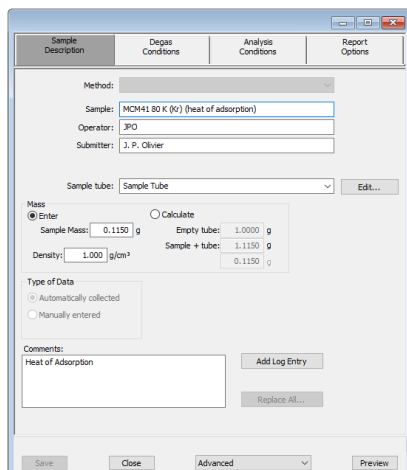

Example of tabbed file editor

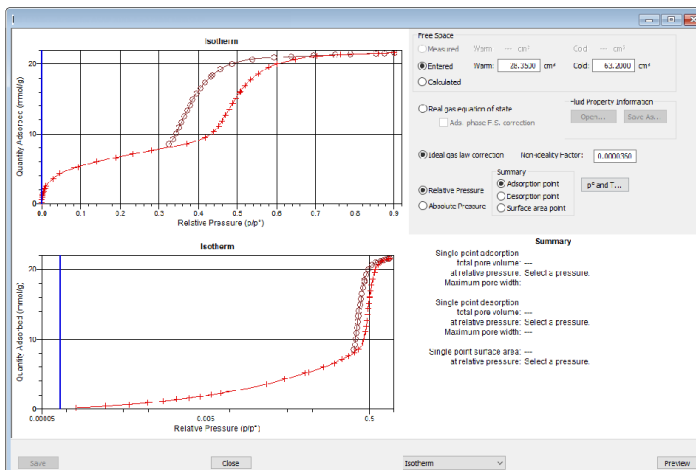

Example of report window

If a sample file with a *Complete* status is opened, to return to the tabbed file editor, select *Advanced* or *Basic* from the drop-down at the bottom of the window.

MANUALLY ENTER DATA

This process allows the manual entry of pressure data from a sample file with a *Complete* status. There are two methods for manually entering data into a sample file:

- Copy and paste onto the graph area of the interactive window
- Import data into the interactive window

COPY AND PASTE MANUALLY ENTERED DATA

1. Open a sample file with a *Complete* status. The file will open to the interactive reports window.
2. Right click in the graph area of the interactive reports window, then select *Copy data*.

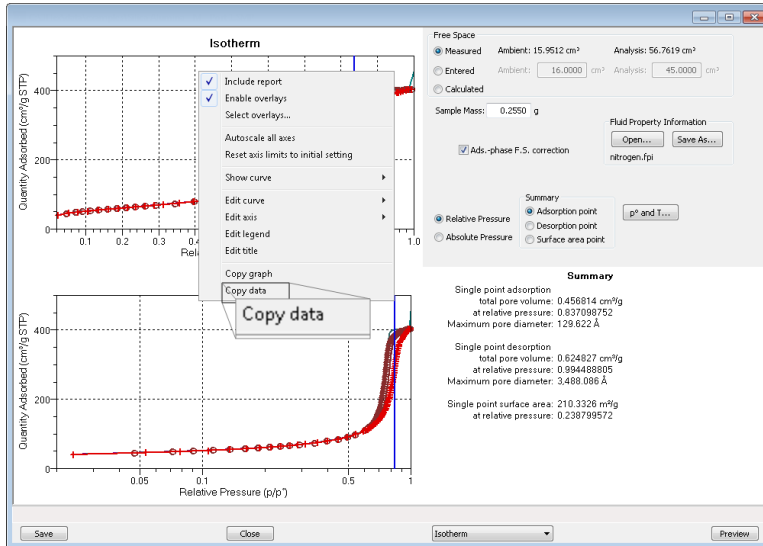

3. Open another sample file using *Advanced* option presentation.
4. On the *Sample Description* tab, select *Manually entered* in the *Type of Data* group box.
5. Click the *Advanced* down arrow at the bottom of the window, then select *Isotherm*.

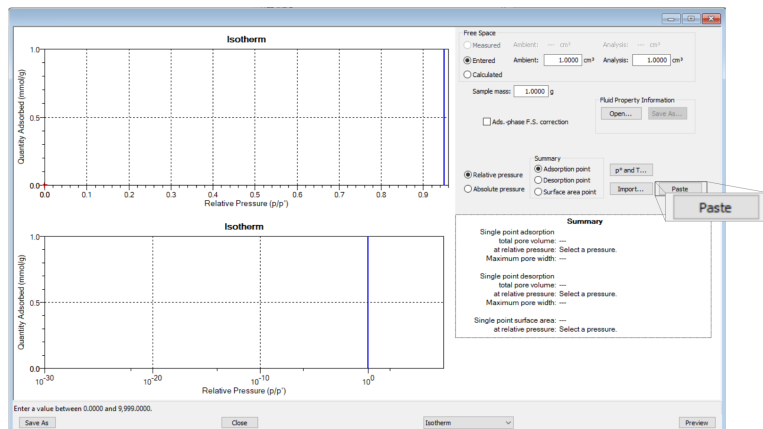

6. Ensure that all parameter fields are set appropriately, then click **Paste**.

IMPORT MANUALLY ENTERED DATA

When importing isotherm data from an external ASCII text file using the **Import** button on the interactive window, the ASCII text file must use the following rules:

ASCII text file format rules

Data must be in two columns and separated by a comma or white-space. Acceptable column headings are:

For Physical Adsorption or Chemical Adsorption:

- Relative Pressure
- Absolute Pressure (mmHg)
- Absolute Pressure (kPa)
- Absolute Pressure (mBar)
- Quantity Adsorbed (mmol/g)
- Quantity Adsorbed (cm³/g STP)
- Quantity Adsorbed (cm³/g STP)

Sample Physical Adsorption ASCII Text File

```

Silica Alumina : Adsorption
Relative Pressure      Quantity Adsorbed (cm3/g STP)
0.108629              50.6657
0.22288               60.7813
0.339909              71.3095
0.459512              84.4172
0.577447              102.672
0.654583              121.707
0.760074              179.096
0.855713              334.565
0.958511              394.675
0.996251              403.793

Silica Alumina : Desorption
Relative Pressure      Quantity Adsorbed (cm3/g STP)
0.996251              403.793
0.86016               389.626
0.753567              256.264
0.664418              133.099
0.542416              96.7366
0.422295              79.7351
0.346371              71.5994
0.2519                62.8256
  
```

0.152718	54.2336
0.103389	49.5803

To import the ASCII text file

1. Open a new sample file in *Advanced* option presentation.
2. On the *Sample Description* tab, select *Manually entered*.
3. Click the *Advanced* down arrow at the bottom of the window, then select *Isotherm*.

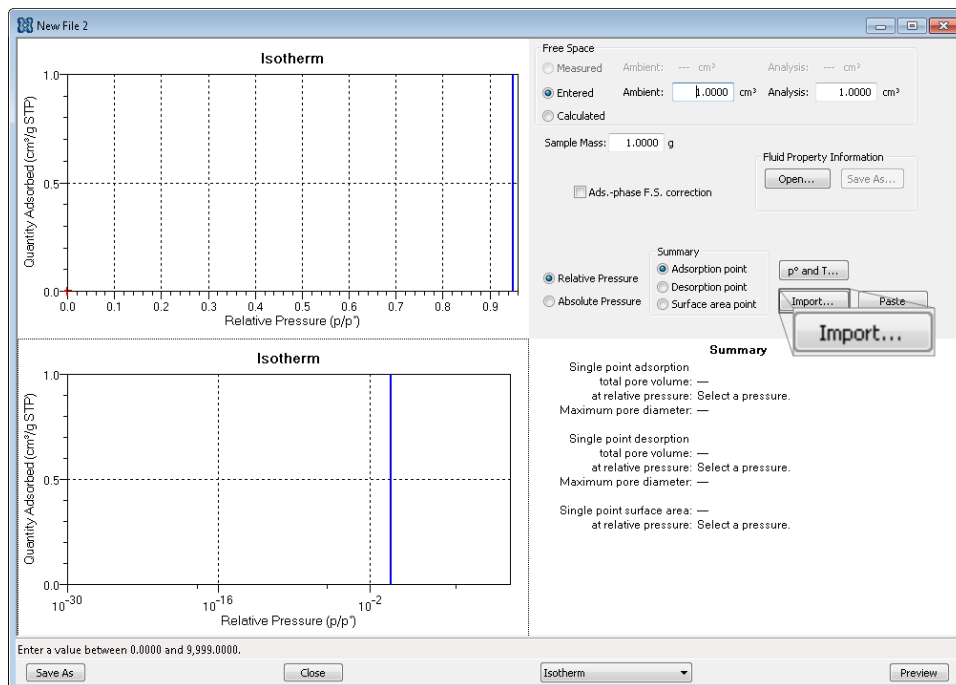

4. Ensure that all parameter fields are set appropriately, then click **Import**.
5. Open the .TXT file. The data from the original sample file is imported and displayed. If an error message appears instead, verify that the .TXT file format is correct.

ACTIVE METALS FOR CHEMICAL ADSORPTION

Options > Active Metals Defaults

(or click [Active Metals](#) on the *Sample Description* tab when using Advanced presentation option)



See also:

[Atomic Weights and Cross Sectional Areas on page A - 1](#)

Up to 20 elements can be specified. At least one element must have a non-zero % of sample weight.

	Element	Atomic Weight	Atomic Cross. Sect. Area (nm ²)	Density (g/cm ³)	% of Sample Weight	% Reduced	MxOy X	MxOy Y
1	chromium	51.996	0.0635	7.190	0.00	100.00	1	0
2	cobalt	58.933	0.0662	8.900	0.00	100.00	1	0
3	copper	63.540	0.0680	8.960	0.00	100.00	1	0
4	molybdenum	95.940	0.0730	10.220	0.00	100.00	1	0
5	nickel	58.710	0.0649	8.902	0.00	100.00	1	0
6	palladium	106.400	0.0787	12.020	0.00	100.00	1	0
7	platinum	195.090	0.0800	21.450	0.00	100.00	1	0
8	rhenium	186.200	0.0649	21.020	0.00	100.00	1	0
9	rhodium	102.905	0.0752	12.410	0.00	100.00	1	0
10	silver	107.868	0.0869	10.500	0.00	100.00	1	0



Enter a unique element name.

OK Cancel

Active Metals

Field or Button	Description
% of Sample Weight * [column]	Percentage, by weight, of each element contained in the sample.
% Reduced * [column]	The percent of metal reduced during preparation.

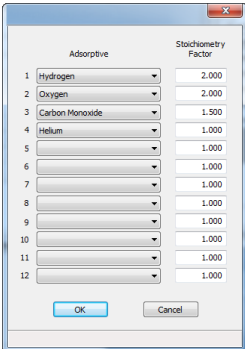
Active Metals (continued)

Field or Button	Description
Adsorptive [button]	<p>Click to display and modify both the adsorptives and their associated stoichiometry factor. Stoichiometry factors for each gas are metal-specific.</p>  <p>Stoichiometry Factor. The stoichiometry factor is defined as the moles of metal species covered per mole of adsorptive.</p>
Atomic Cross Sect. Area (nm ²) [column]	Atomic cross-sectional area of the element.
Atomic Weight [column]	Atomic weight of the element.
Density g/cm³ [column]	Density of the element.
Element [drop-down box]	Select or enter the active metal.
MxOy, X * MxOy, Y * [column]	X and Y values specify the empirical formula for metal and oxygen, respectively, in a metal oxide.
* Options are shown only when using the Active Metals button on the <i>Sample Description</i> tab.	
 <p>For fields and buttons not listed in this table, see Common Fields and Buttons on page 2 - 3.</p>	

4 PARAMETER FILES

Parameter files allow for repeated use of parameter sets. For example — if the same analysis conditions exist for multiple analyses, an *Analysis Conditions* file containing the recurring conditions can be created. When the sample file is created, the *Analysis Conditions* file can be selected for the analysis conditions. Once it becomes part of the new sample file, the new file can be edited as needed without affecting the original *Analysis Conditions* file.

Methods include both analysis conditions and report options, offering the most convenient way to repeat most analyses.

Predefined parameter files are included with the program and can be edited as needed or new parameter files can be created.

The following file types can exist as part of the sample file as well as individual parameter files:

Parameter File Types

File Type	File Extension
Adsorptive Properties	.ADP
Analysis Conditions	.ANC
Degas Conditions P	.DEG
Method	.MTH
Report Options	.RPO
Sample Tube P	.STB

ADSORPTIVE PROPERTIES

File > Open > [.ADP File]

(or click **Edit** next to the *Adsorptive* selection on the *Analysis Conditions* tab when in *Advanced* option presentation)

Adsorptive properties provide the adsorptive (analysis gas) characteristics for the analysis.

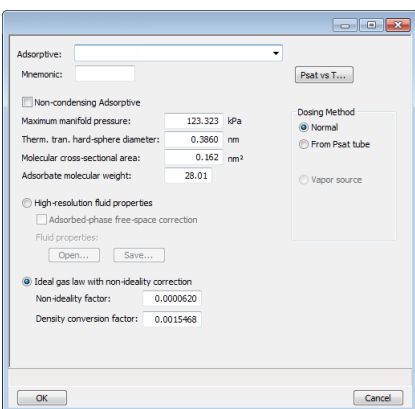

Physical Adsorption

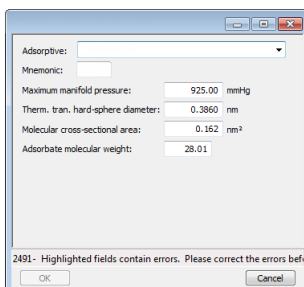

Chemical Adsorption

Adsorptive Properties

Field or Button	Description
Adsorbate molecular weight [text box]	The molecular mass is used for the weight % column of the isotherm tabular report and for the pressure composition isotherm plot.
Adsorbed-phase free-space correction [check box] P	Adsorbed molecules occupy volume in the sample tube, reducing the analysis free space. Select <i>Adsorbed-phase free space correction</i> to adjust the reported quantity adsorbed to correct for this effect. This option is appropriate for all sample analyses that use the real gas equation of state.
Adsorptive [text box]	Name of the adsorptive gas whose properties are being defined.
Density Conversion Factor [text box] P	Factor determined by obtaining the ratio of the gas density (STP) to the liquid volume. This field is disabled if <i>Non-condensing Adsorptive</i> is selected.

Adsorptive Properties (continued)

Field or Button	Description
Dosing Method [group box] P	<p>Normal. Dose from a pressurized tank of gas attached to a gas inlet port.</p> <p>From Psat tube. Select if the Psat tube is to be filled with condensed adsorptive and dosed from the Psat tube. Select this option if using krypton.</p>
High-resolution fluid properties [selection] P	Use to import parameters from a Fluid Properties (.FPI) file. Changing fluid properties should only be necessary if an adsorptive is to be used for which no adsorptive properties are provided. Contact Micromeritics Scientific Services if new fluid properties are required. See Contact Us on page iii .
Ideal gas law with non-ideality correction [selection] P	Use if there is no compressibility table for the gas being used or if you want to match existing data. This factor adjusts the ideal gas law for calculating the quantity of gas in the cold free space. Most gases are nearly ideal near room temperature and at pressures not much above atmospheric pressure, so the cold free space is where the correction is most important. If selected, enter the <i>non-ideality factor</i> field.
Maximum manifold pressure [text box]	The highest pressure to which the manifold will be dosed. To avoid damage to the analyzer, this number is limited to 925 mmHg. Low pressure sources will require lower numbers. For gases to be used for dosing after charging a tube from a gas inlet, enter the maximum pressure for dosing from the inlet, not from the tube of condensate.
Mnemonic [text box]	Enter the mnemonic name for the adsorptive. If this gas is connected to a gas inlet port, this mnemonic must be entered in the <i>Unit Configuration Gas Selection</i> for the inlet port. See Unit Configuration on page 2 - 15
Molecular cross-sectional area [text box]	The area that a single adsorbed molecule occupies on the surface of the sample. It is used in surface area calculations.
Non-condensing Adsorptive [check box] P	Select if using a non-condensing analysis gas. When selected, the <i>Density conversion factor</i> field and the PSAT vs T button are disabled.
Non-ideality factor [text box] P	Compensates for the forces of attraction between molecules in a real gas. This value is used for a calculated free space.
Psat vs T [button] P	Click to edit the <i>Psat vs Temperature</i> table. The table contains saturation pressures and their corresponding temperatures. To edit, click in a field and enter the value.

Adsorptive Properties (continued)

Field or Button	Description
Therm. tran. hard-sphere diameter <i>[text box]</i>	An estimate of molecular size used in calculating the thermal transpiration correction.
 For fields and buttons not listed in this table, see Common Fields and Buttons on page 2 - 3 .	

ANALYSIS CONDITIONS

File > Open > [.ANC File]

(or click the *Analysis Conditions* tab when in *Advanced* option presentation)

Analysis conditions specify the parameters used to guide an analysis.

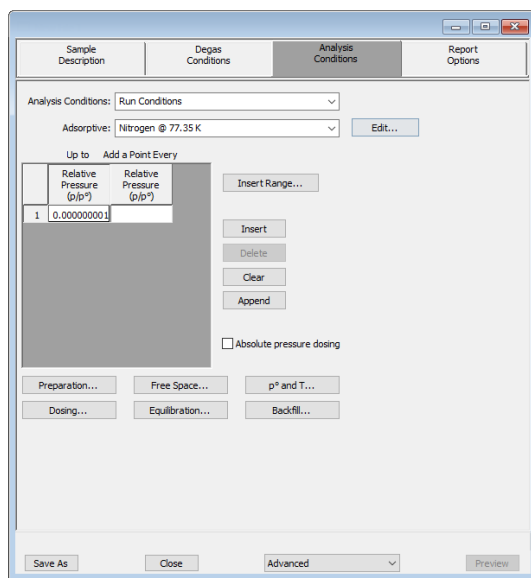

Physical Adsorption

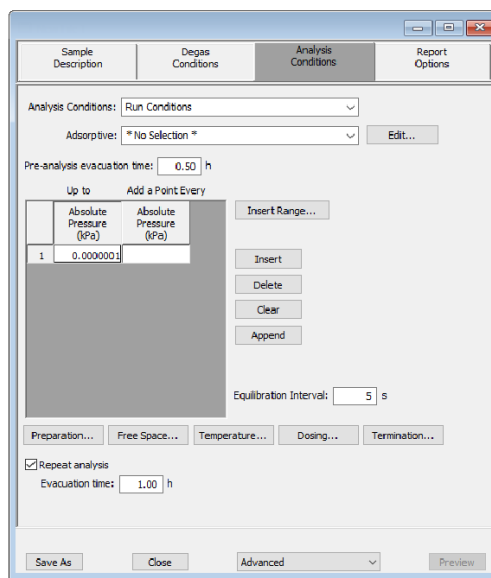



Chemical Adsorption

Analysis Conditions

Field or Button	Description
Absolute pressure dosing [checkbox]	Specifies pressure targets in mmHg, mbar, or kPa instead of relative pressure. If this option is selected, the <i>Relative Pressure</i> labels and entries change to <i>Absolute Pressure</i> in the selected pressure units.
Adsorptive [drop-down box]	Select an <i>Adsorptive Properties</i> file from the list of defined gases to be used for analysis. After selection, click Edit to modify adsorptive properties. See Adsorptive Properties on page 4 - 2 .

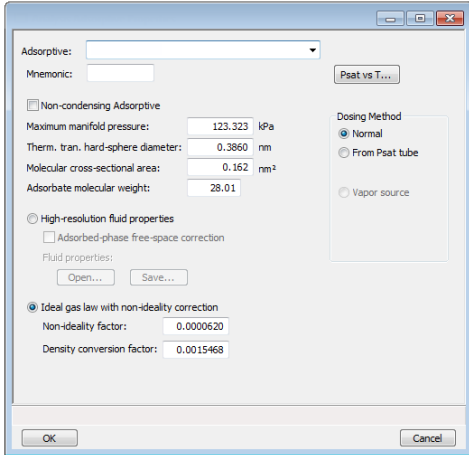
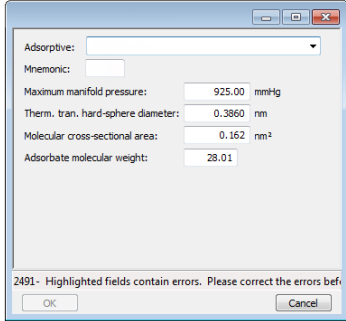
Analysis Conditions (continued)

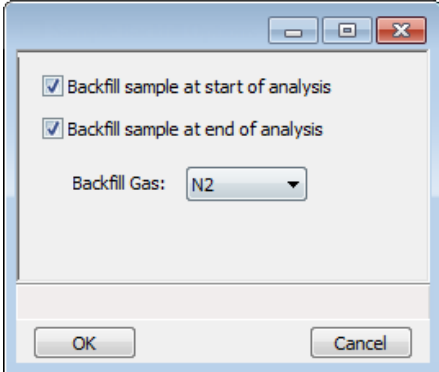
Field or Button	Description
	<div style="display: flex; justify-content: space-around;"> <div style="text-align: center;">  <p>Physical Adsorption</p> </div> <div style="text-align: center;">  <p>Chemical Adsorption</p> </div> </div>
Analysis Conditions [drop-down box]	Use to browse for an <i>Analysis Conditions</i> file that contains analysis condition parameters to be used in the analysis.
Backfill [button] 	<p>Select gas for backfilling the sample tube at the start and end of an analysis.</p>  <p>The options are disabled if the file status is <i>Entered</i>, <i>Complete</i>, or <i>Analyzing</i>.</p>

Analysis Conditions (continued)

Field or Button	Description
Dosing [button]	<p>Options for dosing tolerance, low pressure dosing, and dosing near saturation pressure.</p> <div style="display: flex; justify-content: space-around;"> <div style="border: 1px solid gray; padding: 5px; width: 45%;"> <p> <input type="checkbox"/> First pressure fixed dose: 0.00045 mmol/g <input type="checkbox"/> Maximum volume increment: 1.115369 mmol/g Absolute pressure tolerance: 0.6666 kPa Relative pressure tolerance: 5.0 % <input type="checkbox"/> Low Pressure incremental dose mode Dose amount: 0.00045 mmol/g Equilibration Delay Minimum: 0.00 h Maximum: 999.00 h Maximum number of decants: 6 </p> </div> <div style="border: 1px solid gray; padding: 5px; width: 45%;"> <p> Absolute pressure tolerance: 0.6666 kPa Relative pressure tolerance: 5.0 % <input type="checkbox"/> Low pressure incremental dose mode Dose amount: 0.0446 mmol/g Dose delay: 10 s Enter a value between 0.0000 and 101.3250. </p> </div> </div> <div style="display: flex; justify-content: space-around; margin-top: 10px;"> Physical Adsorption Chemical Adsorption </div> <p>Absolute / Relative pressure tolerance. Values used to determine how close the actual pressure must be to each target pressure from the pressure table. At lower pressures, the relative tolerance value is lower. At higher pressures, the absolute tolerance value is lower. For example:</p> <p>Experiment 1. There might be an absolute tolerance of 5 mmHg, a relative tolerance of 5%, and a target pressure of 40 mmHg; 5% of 40 mmHg is 2 mmHg. Since 2 mmHg (relative tolerance) is lower than 5 mmHg (absolute tolerance), 2 mmHg is used. Therefore a minimum pressure of 38 mmHg (40 - 2) must be attained to collect data for a target pressure of 40 mmHg.</p> <p>Experiment 2. There might be an absolute tolerance of 5 mmHg, a relative tolerance of 5%, and a target pressure of 200 mmHg; 5% of 200 mmHg is 10 mmHg. Since 5 mmHg (absolute tolerance) is lower than 10 mmHg (relative tolerance), 5 mmHg is used. Therefore a minimum pressure of 195 mmHg (200 - 5) must be attained to collect data for a target pressure of 200 mmHg.</p> <p>Normally, surface area measurement points are widely spaced and the resulting measurement is not very sensitive to the precise location of points so wider tolerances may be used. Unnecessarily tight tolerances lengthen the analysis.</p> <p>First pressure fixed dose. </p>



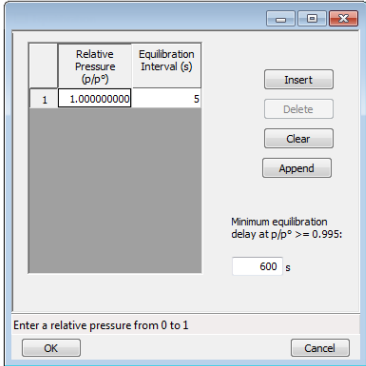

Analysis Conditions (continued)

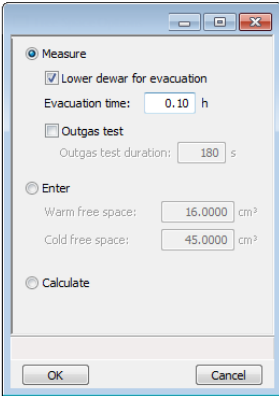
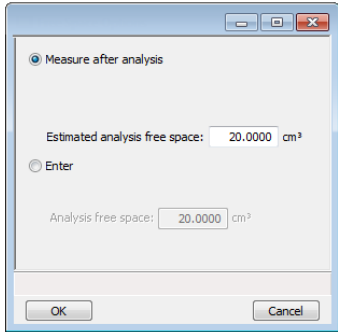
Field or Button	Description
	<p>This option is most frequently used when performing a standard nitrogen analysis of mesoporous materials such as catalysts. If the first pressure table point is low and the gas uptake of the sample is expected to be high, this option can shorten the time required to reach the first point on the pressure table.</p> <p>The sample is dosed repeatedly at low pressures with a specified amount of gas until the first pressure point is reached. This initial dosing quickly meets the adsorptive demand of the sample.</p> <p>The first point on the pressure table is the threshold value, triggering the transition from the <i>Fixed Dose Mode</i> to <i>Pressure Table Mode</i>. When the first pressure table value is reached, <i>Fixed Dose Mode</i> is disabled, and points are equilibrated and recorded in accordance with the specified pressure table.</p> <p>Enter the amount of gas to be added to the sample for each dose cycle.</p> <p>Maximum volume increment. P Select to determine when additional data points are collected between target pressures in regions of adsorption. When the maximum increment has been adsorbed since the last collected data point, another point is equilibrated and collected. During desorption, this field is treated as a maximum volume decrement value.</p>
Equilibration <i>[button]</i> P	<p>Provides options to specify the equilibration interval and delay time.</p> <div style="display: flex; align-items: center; justify-content: center;">  <div style="margin-left: 20px; border: 1px solid gray; border-radius: 10px; padding: 10px; background-color: #f0f0f0;"> <p>Column heading reads Absolute Pressure (mmHg) when Absolute Pressure Dosing is selected.</p> </div> </div> <p>Minimum equilibration delay at $p/p_0 \geq 0.995$. The minimum number of seconds required before equilibration can occur for a</p>

Analysis Conditions (continued)

Field or Button	Description
	<p>relative pressure greater than or equal to 0.995. This field is not available if <i>Absolute pressure dosing</i> is selected on the <i>Analysis Conditions</i> tab.</p> <p>Relative Pressure (p/p⁰) or Absolute Pressure. The pressure the equilibration interval will be applied.</p>
Equilibration interval [text box] C	The number of seconds between successive pressure readings during equilibration. Long equilibration intervals tend to lengthen analyses, however, they do improve data integrity. Short equilibration intervals produce a faster analysis but may reduce the accuracy of data.
Free Space [button]	How the free space is to be measured. <div style="display: flex; justify-content: space-around; align-items: center; margin-top: 20px;"> <div style="text-align: center;">  <p>Physical Adsorption</p> </div> <div style="text-align: center;">  <p>Chemical Adsorption</p> </div> </div>
Free Space P (continued)	<p>Measure</p> <ul style="list-style-type: none"> • Lower dewar for evacuation. If the dewar is to be lowered for evacuation, select this option and enter the length of time for evacuation after the free space measurement in the <i>Evacuation time</i> field. If using a cryostat, the operator must manually move the cryostat assembly when prompted. • Evacuation time. The length of evacuation time prior to free space measurement. • Outgas test. Checks for system leaks or sample outgassing. After free space is measured, the dewar is lowered and the sample evacuated for the specified amount of time. The leak test is performed after evacuation. If the pressure rises more than 0.025 mmHg within the time specified in the <i>Outgas test duration</i> field, outgassing is present. If a leak is found, the leak test repeats nine times, with 30

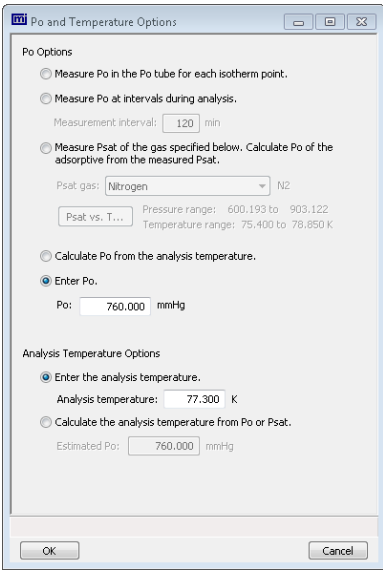

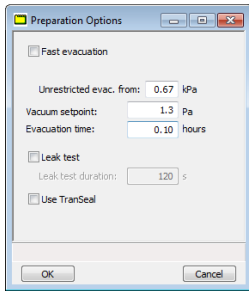
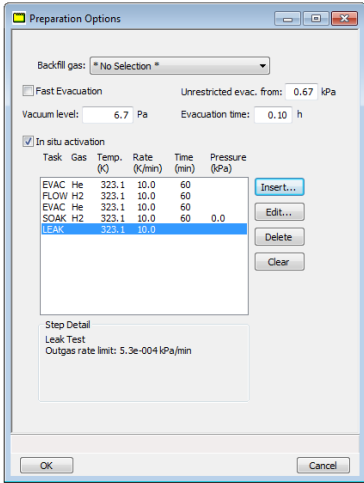

Analysis Conditions (continued)

Field or Button	Description
	<p>minutes evacuation between tests. If the 10th leak check fails, the analysis stops and the operator is notified. While leak testing slightly increases analysis time, it prevents the continuation of analysis and collection of erroneous data if a leak occurs.</p> <p>Enter. Allows manual entry of free space.</p> <p>Calculate. Use to have the free space measurement calculated using the sample and tube parameters.</p>
<p>Free Space  (continued)</p>	<p>Enter. Allows manual entry of free space.</p> <p>Measure after analysis. Measures free space after analysis ends. Enter the estimated free space measurements.</p>
<p>p° and Temperature Options [button] </p>	<p>How the saturation pressure (P_0) is to be measured or calculated and the analysis bath temperature.</p> <div data-bbox="558 856 938 1423" style="border: 1px solid gray; padding: 5px; margin: 10px 0;">  </div> <p>p° Options. Select one option indicating how P_0 is to be measured or calculated.</p> <hr/> <div data-bbox="558 1570 1438 1705" style="border: 1px solid green; padding: 5px; margin: 10px 0;">  <p>If using a cryostat, select either the <i>Calculate p_0</i> or <i>Entered p_0</i> option. Also enter an analysis temperature.</p> </div> <hr/> <p>Analysis Temperature Options. Select an option to enter analysis temperature manually, or choose to have it automatically calculated</p>





Analysis Conditions (continued)

Field or Button	Description
	<p>from p° or P_0. An estimated P_0 can be entered if a <i>measured</i> P_0 option is selected.</p> <p>Psat Gas. If choosing to measure the P_0 for each isotherm point using a gas other than the adsorptive, select the P_0 gas from the drop-down list, then click Edit to modify the P_0 adsorptive properties. Refer to the <i>Adsorptive</i> drop-down list earlier in this table for details on editing this window.</p>
Pre-analysis evacuation time [text box]	<p>Evacuation is required prior to analysis. The default setting is 30 minutes.</p> <p>Preparation. Use to set the evacuation rate, unrestricted pressure, and setpoint.</p> <p>Temperature. Use to set the temperature and ramp rate.</p>
Preparation [button] <div style="display: flex; justify-content: space-around; margin-top: 20px;"> <div style="text-align: center;">  <p>Physical Adsorption</p> </div> <div style="text-align: center;">  <p>Chemical Adsorption</p> </div> </div>	<p>Evacuation rate / time / level, leak test and time values, elevator prompts, and in situ degassing or activation.</p> <p>Evacuation time. The length of time for preliminary evacuation.</p> <p>Fast evacuation. Select for samples (such as pellets) that do not fluidize or shed particles during evacuation.</p> <p>Unrestricted evac. from. The pressure at which unrestricted evacuation is to begin. This option is enabled when <i>Fast evacuation</i> is not selected.</p>

Analysis Conditions (continued)

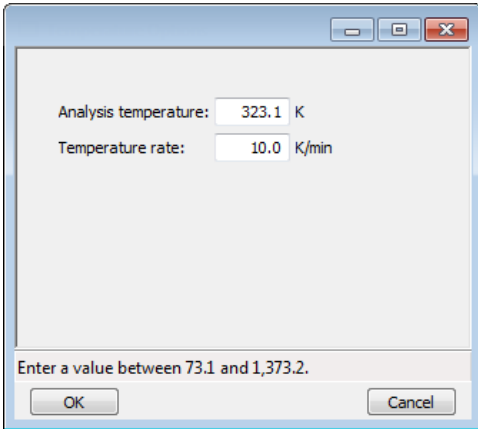
Field or Button	Description
Preparation  (continued)	<p>Leak test. Enables the system to check for leaks or sample outgassing before the analysis. The leak test allows sample pressure to rise during the test. If the pressure rises more than 0.15 mmHg, the analysis does not proceed and the operator is notified. While leak testing slightly increases analysis time, it prevents the continuation of analysis and collection of erroneous data if a leak exists.</p> <p>Use TranSeal. Select if using the TranSeal to transfer the sample from the preparation port to the analysis port under vacuum.</p> <p>Vacuum setpoint. The vacuum level to be achieved before timed evacuation begins.</p>
Preparation  (continued)	<p>Backfill gas. Lists the available backfill gases.</p> <p>Vacuum level. The pressure for unrestricted evacuation.</p> <p>In situ activation. When selected, preparation steps will be done. If not selected, the task table is disabled and analysis starts after the preliminary evacuation.</p> <hr/> <div style="display: flex; align-items: center;">  <p>See Chemical Adsorption Tasks on page 4 - 14 for information on inserting tasks for a chemical adsorption analysis.</p> </div> <hr/>
Repeat analysis <i>[check box]</i> 	<p>Pressure at which heating will stop and hold the sample temperature approximately constant until the pressure falls below the <i>Hold pressure</i>. This feature prevents damage to the sample structure due to 'steaming', as well as sample elutriation due to excessive escaping gas velocity.</p>

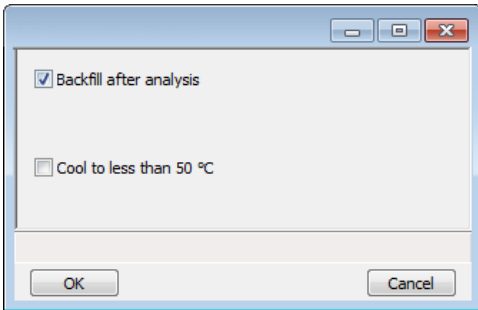
Analysis Conditions (continued)

Field or Button	Description
Temperature [text box] 	Provides access to furnace and accessory temperature control.  Analysis temperature. Enter the analysis temperature. Temperature rate. Enter the analysis temperature rate.
Termination [button] 	Backfill options after analysis.  Select the backfill gas if backfill is to be done after the analysis. Cool to less than 50 °C. Select to enable the cool down option.
 <p>For fields and buttons not listed in this table, see Common Fields and Buttons on page 2 - 3.</p>	

CHEMICAL ADSORPTION TASKS

File > Open > [.SMP File] > Analysis Conditions tab > Preparation > Insert

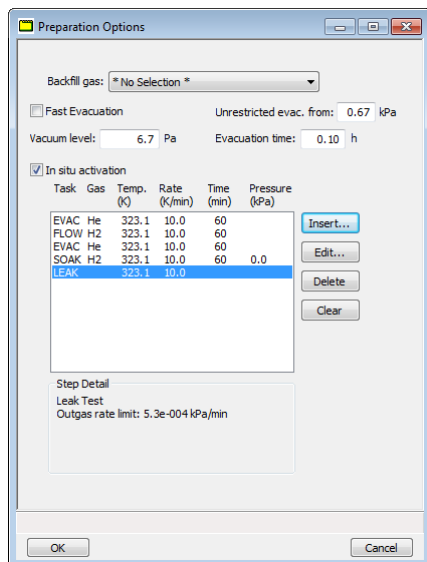

To ensure safe operation and reliable results, an evacuation task should be included:

- between tasks using different gases
- preceding a leak test

An evacuation will be performed at the analysis temperature for the *Pre-analysis Evacuation Time* after the last task and before analysis.

Chemical Adsorption Tasks

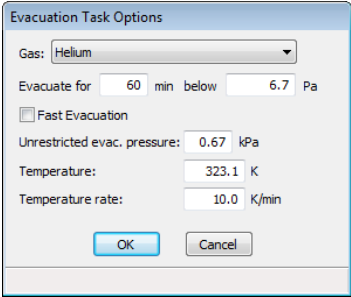
Task	Description
Evacuation [selection]	 <p>Evacuate for [n] below [n]. The minutes and pressure for preliminary evacuation.</p> <p>Evacuation rate. The rate for restricted evacuation.</p>

Chemical Adsorption Tasks (continued)

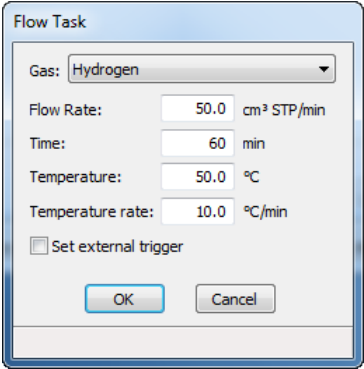
Task	Description
	<p>Fast Evacuation. Select for samples (such as pellets) that do not fluidize or shed particles during evacuation.</p> <p>Gas. Gas used for the evacuation task.</p> <p>Temperature. The temperature to reach during evacuation.</p> <p>Temperature rate. Enter the analysis temperature rate.</p> <p>Unrestricted evac. pressure. The pressure at which unrestricted evacuation is to begin. This option is enabled when <i>Fast evacuation</i> is not selected.</p>
<p>Flow [selection]</p>	<div data-bbox="558 709 919 1075" data-label="Image">  </div> <p>Flow Rate. The rate at which gas is to flow.</p> <p>Gas. Gas used for the flow task.</p> <p>Set external trigger. If selected, the contact closure used to trigger an external Mass Spectrometer or Calorimeter will be activated. If deselected, the contact closure will be deselected.</p> <p>Temperature. The temperature at which the gas will flow for the specified time.</p> <p>Temperature rate. Enter the analysis temperature rate.</p> <p>Time. The duration of time the sample should remain at the specified temperature.</p>

Chemical Adsorption Tasks (continued)

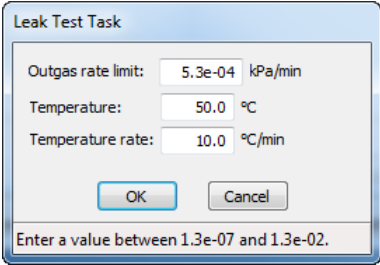
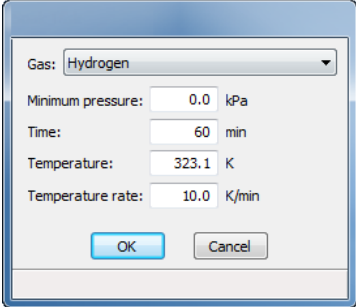
Task	Description
Leak Test <i>[selection]</i>	 <p>Outgas rate limit. If a measured leak or outgas rate exceeds the entered value, the test will be reported as failed. Analysis will not be canceled.</p> <p>Temperature. The target temperature for the leak test.</p> <p>Temperature rate. Enter the analysis temperature rate.</p>
Soak <i>[selection]</i>	 <p>Gas. Gas used during the soak task.</p> <p>Minimum pressure. The minimum pressure to be maintained over the sample during the soak.</p> <p>Temperature. The temperature at which sample is to be soaked.</p> <p>Temperature rate. Enter the analysis temperature rate.</p> <p>Time. The duration of time the sample is to soak at the specified temperature.</p>

EVACUATION RULES FOR CHEMICAL ADSORPTION

Evacuation parameters apply to all four stages of evacuation with the exception of evacuation time. Evacuation time is set using the fields specified in the following evacuation rules.

When an analysis starts, evacuation begins:

1. at ambient temperature before the first preparation step. This step uses the *Evacuation time* field on the *Preparation Options* window.
2. at analysis temperature after preparation and prior to the start of the analysis stage. This step uses the *Pre-analysis evacuation time* field on the *Analysis Conditions* window.
3. at analysis temperature before the repeat analysis if *Repeat analysis* is selected on the *Analysis Conditions* window. This step uses the *Repeat Analysis / Evacuation time* field.
4. at analysis temperature before the free space measurement if *Measure after analysis* is selected on the *Free Space Options* window. This step evacuates for 90 minutes.

DEGAS CONDITIONS

File > Open > [.DEG File]

(or click the *Degas Conditions* tab when in *Advanced* option presentation)

Degassing is a required step in preparation for an analysis. The *Degas Conditions* tab provides settings that will be automatically applied during the degassing procedure.

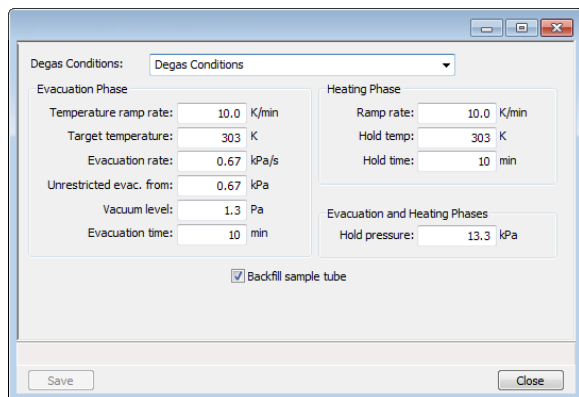

Degas Conditions

Field or Button	Description
Backfill sample tube [checkbox]	Indicate if the sample tube should be backfilled automatically or wait for operator response.
Degas Conditions [drop-down box]	Use to browse for a .DEG file that contains degas condition parameters to be used in the analysis.
Evacuation and Heating Phases [group box]	Hold pressure. Pressure at which heating will stop and hold the sample temperature approximately constant until the pressure falls below the <i>Hold</i> pressure. This prevents damage to the sample structure due to 'steaming' and /or elutriation due to excessive escaping gas velocity.
Evacuation Phase [group box]	Options provide conditions for the evacuation phase of the degassing operation. Temperature ramp rate. Rate at which the temperature is to change when advancing to the target pressure. Target temperature. Targeted temperature for evacuation. Evacuation Rate. Rate used for evacuation. Unrestricted evac. from. Pressure at which the unrestricted

Degas Conditions (continued)

Field or Button	Description
	evacuation is to begin. Vacuum level. Evacuation time starts when the vacuum level is reached. Evacuation time. Length of time for preliminary evacuation before proceeding with the <i>Heating Phase</i> temperature schedule. The timer starts when the vacuum level is reached.
Heating Phase <i>[group box]</i>	Options provide conditions for the heating phase while degassing. Ramp rate. The rate at which the temperature will change while advancing to the hold temperature. Hold temp. Temperature at which the sample is to be held while degassing. Hold time. How long the sample is to be held at the specified temperature before beginning to cool down.
 For fields and buttons not listed in this table, see Common Fields and Buttons on page 2 - 3 .	

REPORT OPTIONS

File > Open > [.RPO File]

(or click the *Report Options* tab when in *Advanced* option presentation)



See also:

- [About Reports on page 7 - 1](#)
- [Selected Reports on page 8 - 1](#)

Log in to your [customer portal](#) to access MicroActive Report Tutorials and the Calculations document.

Additional reports are available using the *Reports* menu.

Use to specify report options for data collected from an analysis or manually entered data. *Report Options* files also help in customizing report details such as axis scale, axis range, column headings, and components of thickness curve equations. These files may contain tabular reports, plots, or both, as well as advanced report tables.

Customized report options files can be created then loaded into a sample file, allowing quick generation of reports.

Report Options files may be defined to include overlay options. This system allows the overlay of up to 25 plots of different samples onto a plot of the same type or overlay one plot type onto a different plot type from the same analysis. See [Graph and Sample Overlays on page 7 - 26](#).



Physical Adsorption

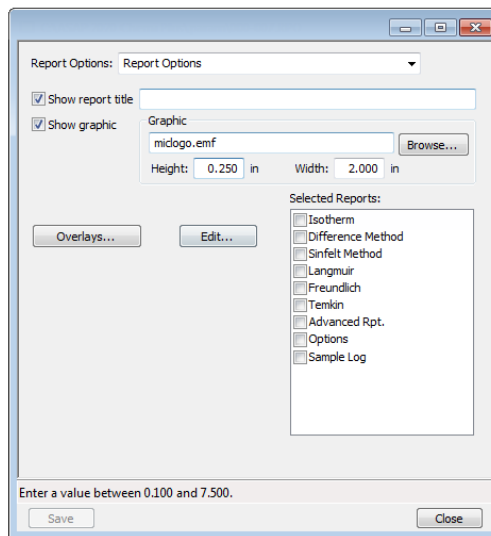

Chemical Adsorption

Report Options

Field or Button	Description
Apply thermal transpiration correction [check box]	Use to correct the temperature-induced pressure difference between the manifold and the chilled sample tube. This option is most significant for pressures less than approximately 1.0 mmHg. Always use thermal transpiration when performing micropore analyses. Inside diameter of sample tube. Enabled when <i>Apply thermal transpiration correction</i> is selected. Enter the inside diameter of the sample tube used in the analysis. See the <i>Thermal Transpiration Correction</i> section of the <i>Calculations</i> document. Log in to your customer portal to access the <i>Calculations</i> document.
Overlays [button]	See Graph and Sample Overlays on page 7 - 26 .
Report Options [drop-down box]	Browse for a .RPO file that contains report options parameters to be used in the report.
Selected Reports [group box]	Select the report names to include in the report.
Show graphic [check box]	Use to show a graphic on the report header. Height/Width. Enter the height and width of the selected graphic. These values determine the graphic appearance on the generated report.

Report Options (continued)

Field or Button	Description
Show report title <i>[check box]</i>	Select and enter a report title to appear on the report header.
	For fields and buttons not listed in this table, see Common Fields and Buttons on page 2 - 3.

SAMPLE TUBE FOR PHYSISORPTION

File > Open > [.STB File]

(or click **Edit** next to the *Sample Tube* selection on the *Sample Description* tab when in *Advanced* option presentation)

Sample Tube files specify information about the sample tube.

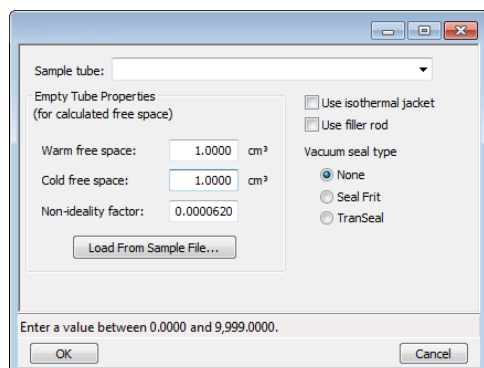

Sample Tube

Field or Button	Description
Cold free space [text box]	Empty sample tube gas capacity measured with the dewar raised.
Load from Sample File [button]	Loads parameters from the selected sample file.
Non-ideality factor [text box]	Compensates for the forces of attraction between molecules in a real gas. This value is used for a calculated free space.
Sample tube [drop-down box]	It is a good practice to label each sample tube with a unique identification. Enter that information here. This information will also appear in the <i>Sample Tube</i> drop-down list on the <i>Sample Description</i> tab.
Use filler rod [check box]	Select if a filler rod is to be used in the sample tube. A filler rod reduces the stem free space volume resulting in reduction of free space error. It is generally a good practice to use filler rods for samples having less than 100 square meters of total surface area.

Sample Tube (continued)

Field or Button	Description
Use isothermal jacket <i>[check box]</i>	Select if an isothermal jacket is to be used. An isothermal jacket maintains a constant temperature profile along the sample tube stem during an extended analysis of more than 1 or 2 hours.
Vacuum seal type <i>[group box]</i>	Select the seal type to be used.
Warm free space <i>[text box]</i>	Empty sample tube gas capacity measured at room temperature.
<div style="display: flex; align-items: center;">  <p> For fields and buttons not listed in this table, see Common Fields and Buttons on page 2 - 3. </p> </div>	

5 DEGASSING

Most solid materials absorb moisture and other contaminants when exposed to the atmosphere. The sample must be clean when an analysis is performed. The degas process heats the sample to remove the moisture and contaminants.

START DEGAS

Unit [n] > Start Degas

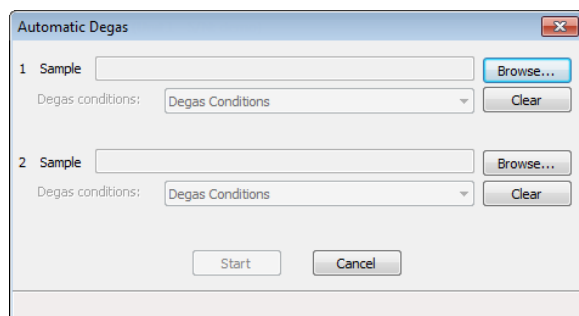

Select the file for each degas port to be used, then load the sample into the sample tube and install the sample tube on the degas port. Allow the sample to cool before transferring to the analysis port to start the analysis.

TRANSFER A DEGASSED PHYSICAL ADSORPTION SAMPLE TO AN ANALYSIS PORT



See also:

[Worksheets on page K - 1](#)

The sample tube must be removed from the degas port, weighed, and then installed onto the analysis port for analysis.



If the sample tube will not be mounted on the analysis port immediately, leave it on the degas port. If it is necessary to remove the sample tube and a Seal Frit was not used, insert a rubber stopper into the sample tube.

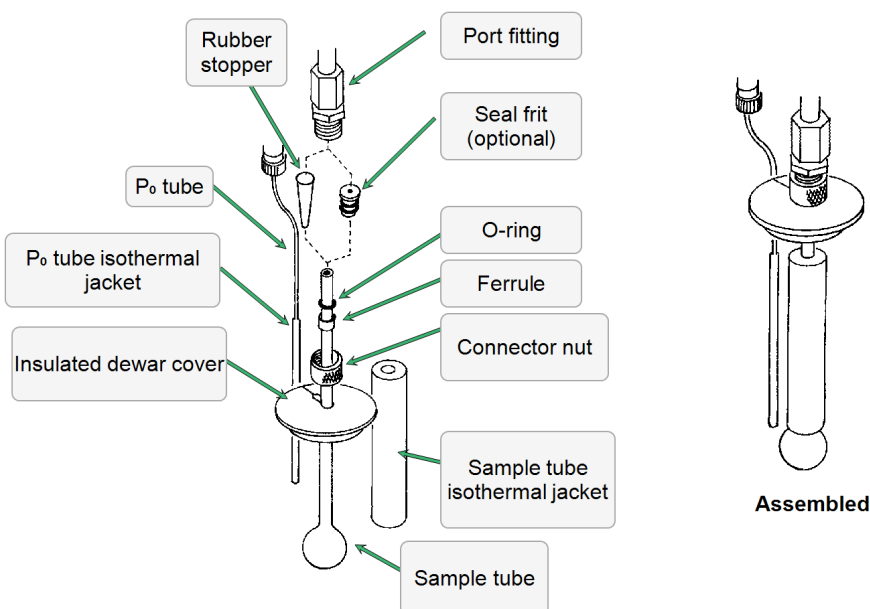

1. Allow the sample tube to cool.



Do not touch the sample tube or the heating mantle until they have reached room temperature. Touching the sample tube, heating mantle, or heating mantle clip before they have cooled could result in burns.

2. Carefully remove the heating mantle clip and the heating mantle from the sample tube.
3. Hold the sample tube, loosen the port connector nut, and remove the sample tube from the degas port.
4. Remove the connector nut, ferrule, and O-ring from sample tube stem.

5. Weigh the sample tube set. Use the *Sample Data Worksheet* to determine the sample mass.
6. Slide an isothermal jacket down over the sample tube stem until it touches the sample tube bulb.
7. Place the connector nut, ferrule, and O-ring onto the sample tube stem.
8. Remove the stopper and immediately attach the sample tube to the analysis port, pushing it fully up into the port. Secure it in place by screwing the connector nut onto the analysis port connector; hand tighten the connector nut. If a Seal Frit was used, it does not have to be removed.
9. Place the dewar cover over the sample tube stem just above the isothermal jacket.

TRANSFER A DEGASSED CHEMICAL ADSORPTION SAMPLE TO AN ANALYSIS PORT



See also:

[Worksheets on page K - 1](#)



If the sample tube will not be mounted on the analysis port immediately, leave it on the degas port. If it is necessary to remove the sample tube and a Seal Frit was not used, insert a rubber stopper into the sample tube.

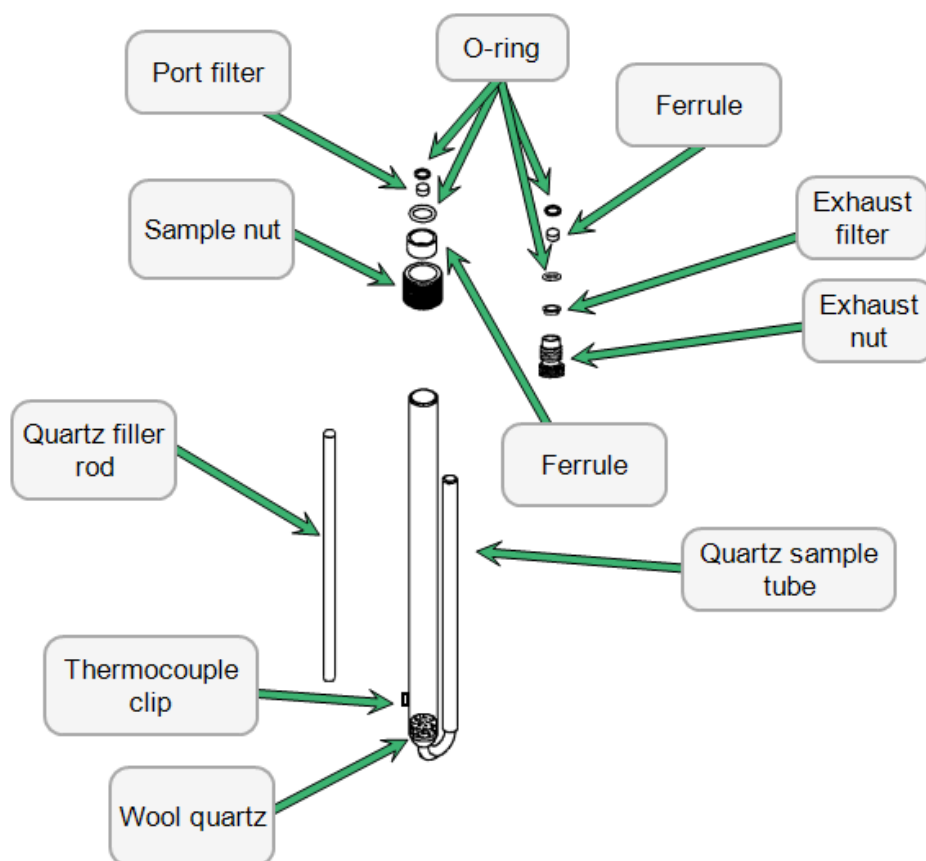

1. Allow the sample tube to cool to room temperature (approximately 15 minutes).



Do not touch the sample tube or the heating mantle until they have reached room temperature. Touching the sample tube, heating mantle, or heating mantle clip before they have cooled could result in burns.

2. While holding the sample tube, loosen the port connector nut and remove the sample tube from the degas port. Immediately insert a rubber stopper into the sample tube.
3. Remove the connector nut, ferrule, and O-ring from sample tube stem.
4. Weigh the sample tube set. Use the *Sample Data Worksheet* to determine the sample mass.
5. Slide an isothermal jacket down over the sample tube stem until it touches the sample tube bulb.
6. Place the connector nut, ferrule, and O-ring onto the sample tube stem.
7. Remove the stopper and immediately attach the sample tube to the analysis port, pushing it fully up into the port. Secure it in place by screwing the connector nut onto the analysis port connector. Hand tighten the connector nut.
8. Insert the temperature thermocouple in to the clip on the sample tube.
9. Place the dewar cover over the sample tube stem just above the isothermal jacket.
10. Place the furnace onto the elevator.
11. Slide the insulator dewar cover onto the sample tube.
12. Open the instrument schematic and raise the elevator.
13. Ensure the insulating dewar cover remains properly seated on the top of the furnace.

ENABLE MANUAL CONTROL OF DEGAS PORTS

Unit [n] > Degas > Enable Manual Control

Unit [n] > Degas > Show Degas Schematic



See also:

See [Show Degas Schematic on page 5 - 7](#)

Use to enable the manual control of degas ports.

SHOW DEGAS STATUS

Unit [n] > Degas > Show Status

Use to show the current status for each port.

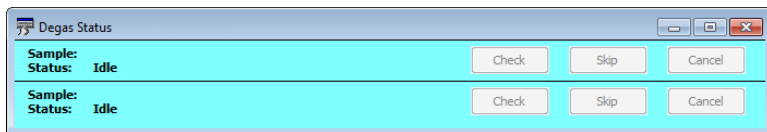

Show Degas Status

Field or Button	Description
Cancel [button]	Discards any changes or cancels the current process.
Check [button]	<p>Click to check the outgassing rate of the sample on the selected port. The following actions occur:</p> <ul style="list-style-type: none"> The current degassing step is suspended (on both ports). Degassing can be checked after the vacuum setpoint has been attained, or during a temperature ramp and hold. If using this option during any other step, a message indicating the <i>SmartVac Prep is not in a valid state</i> is displayed. The vacuum valves are closed and the vacuum level monitored. The <i>Status</i> window is displayed (if not already displayed). The <i>Status</i> window will indicate that the degassing operation is being checked and will display the outgassing rate as it becomes available. <p>During the degas check, the Check button changes to Continue. When Continue is clicked, the valves open, the temperature ramp or hold continues, and the degassing operation resumes. If the outgassing rate indicated that contaminants have been removed from the sample (minimal pressure increase), click Skip to advance to the next state of the degassing operation. For example, if degassing is checked degassing after the setpoint is attained, Skip advances the process to the ramping stage.</p>
Sample	The sample file being used with the degassing operation for each port.
Skip [button]	Skips the current stage of the degassing operation for the selected port.
Status	The current stage of the degassing operation for each port.

SHOW DEGAS SCHEMATIC

Unit [n] > Degas > Show Degas Schematic

Use to display the degas schematic. To operate the valves and elevator from this window, manual control must be enabled (**Unit [n] > Degas > Enable Manual Control**).

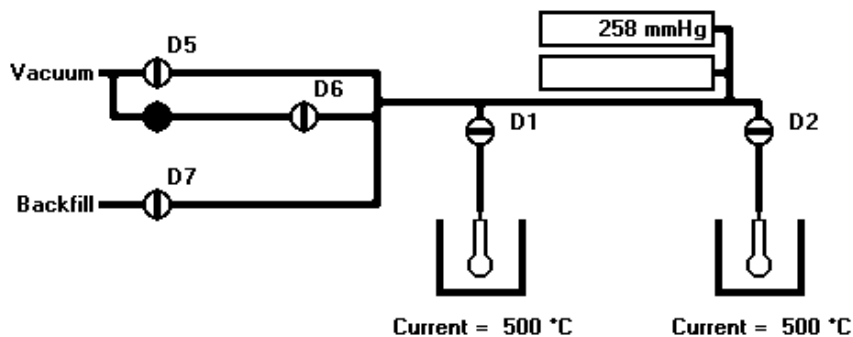

Analyzer Schematic Icons

Icon or Symbol	Description
	Open Valve. Green indicates an open valve.
	Closed Valve. Yellow indicates a closed valve.
	Servo Valve. Closed.
	Servo Valve. Open.
	Elevator.
	Sample Tube. Cannot be manually controlled.

Degas Schematic Components

Schematic Components	Description
D1 and D2	Sample port valves
D5	Vacuum valve
D6	Servo isolation valve
D7	Gas inlet port valve

SCHEMATIC SHORTCUT MENUS

Each manually controlled schematic component has a shortcut menu displaying the operations available for that particular component. To access the shortcut menu, hover the mouse pointer over the component icon and right click.

Schematic Shortcuts

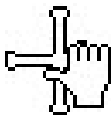
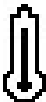
Schematic Shortcut Icon	Available Options:
Valve options 	Open. Opens the selected valve. Close. Closes the selected valve.
Temperature control options 	Disable. Disables the temperature control. Set. Select to set the ramp rate and target temperature.

6 PERFORM AN ANALYSIS



If using a cryostat for analysis, see [CryoStat on page D - 1](#) prior to use.

DEWAR PRECAUTIONS



Always handle glass dewars with care. Any product incorporating a vacuum is a potential safety hazard and should be treated with caution. If in doubt, contact your safety officer.

Do not pour liquid nitrogen directly into a sink. Doing so may cause drain pipes to burst.

When handling dewars containing liquefied gases or cryogenic liquids:

- Wear protective equipment:
 - goggles or face shield
 - an insulated or rubber apron
 - insulated gloves
- When pouring liquefied gases from one container to another:
 - cool the receiving container gradually to minimize thermal shock
 - pour the liquefied gas slowly to prevent splashing
 - vent the receiving container to the atmosphere

FOR GLASS DEWARS

- Use a plastic stirring rod when stirring substances in a dewar containing liquefied gases (or other materials of extremely low temperature). Do not use a glass or metal stirring rod unless it has a protective coating.
- Do not handle heavy objects above the dewar. If unavoidable, place a protective cover over the dewar opening. If an object of sufficient weight is accidentally dropped into the dewar, shattering may occur.
- If the dewar has a protective mesh covering, do not remove it. This cover minimizes the risk of flying particles should the dewar be knocked over, dropped, or broken.

CHECK THE CRYOGEN LEVEL

If performing an analysis that requires use of the cold trap and cryogen, check the cryogen level in the dewar. It should be about 25 mm (1 in.) from the top.



The cryogen must not be cold enough to trap the carrier gas or analysis gas. Do not use liquid nitrogen with argon carrier gas. For example, use an alcohol and liquid nitrogen slurry (-80 °C).



Use appropriate safety procedures when handling all cryogenes. Be sure to wear safety glasses and gloves, and observe the precautions listed earlier.

PREPARE FOR ANALYSIS

The steps in this topic properly prepare the equipment for an analysis. It is recommended to perform the tasks in the provided order.



See also:

- [*Dewar Precautions on page 6 - 1*](#)
- [*Select a Sample Tube on the next page*](#)
- Step 1 - [*Clean and Label Sample Tubes on page 6 - 5*](#)
- Step 2 - [*Create the Sample File on page 6 - 7*](#)
- Step 3 - [*Determine the Sample Mass on page 6 - 8*](#)
- Step 4 - [*Degas the Sample on page 6 - 13*](#)
- Step 5 - [*Sample Tube Installation on page 6 - 16*](#)
- Step 6 - [*Fill and Install the Dewar on page 6 - 19*](#)

SELECT A SAMPLE TUBE

A sample tube set consists of:

- Sample tube
- Stopper or Seal Frit
- Filler rod

Standard sample tubes for the analyzer have a 1.27 cm (1/2 in.) outside diameter (OD). Stepped ferrules, smaller O-rings, isothermal jackets, and filler rods are available for adapting the smaller stems to the degas or analysis ports. The stem diameter selected for use is a matter of accuracy and precision requirements, as well as personal preference and convenience in loading the sample.

A rubber stopper may be used with all size sample tubes; however, seal frits are recommended for 1.27 cm (1/2 in.) OD sample tubes.

Filler rods help to ensure accuracy in samples with lower total surface areas by reducing the free space volume. It is generally a good practice to use filler rods for samples having less than 100 square meters of total surface area. Filler rods are unnecessary for samples with total surface areas greater than 100 square meters.



Filler rods can interfere with thermal transpiration correction and, therefore, should not be used when performing micropore analyses.

The weight of the empty sample tube should be determined after it has been cleaned, degassed, and filled with backfill gas. The sample tube should be allowed to cool to room temperature before backfilling. After the sample tube has cooled, remove it from the degas port and weigh it.



If a Seal Frit is not used, insert a stopper immediately after removing the sample from the degas port.

The mass of the isothermal jacket may vary slightly and cannot be considered as constant; therefore, do not weigh it with the sample tube set.

CLEAN AND LABEL SAMPLE TUBES



The equipment images in this topic may differ slightly from your equipment, however the instructions are the same unless otherwise noted.

Sample tubes and filler rods must be clean and dry before samples are added and weighed. The following table indicates which materials are supplied by Micromeritics and which are supplied by the user. The procedures following the materials table are recommended.

Supplied by Micromeritics	Supplied by User
<ul style="list-style-type: none"> • Filler rod • Funnel • Sample data worksheet • Sample tube • Sample tube brush • Sample tube rack • Sample weighing support (required for chemical adsorption sample tubes) • Stopper for sample tube 	<ul style="list-style-type: none"> • Acetone or isopropyl alcohol • Analytical balance • Cryogen for cold trap dewar • Detergent (such as Alconox) • Drying oven • Forceps • Insulated gloves • Pipe cleaners • Rubber gloves or lint-free cloth • Safety glasses • Ultrasonic cleaning unit • Waste container

1. Preheat drying oven to 110 °C.
2. Verify that the ultrasonic cleaning unit is clean.
3. Use 5 grams of Alconox (or other suitable detergent) per 500 mL of warm water and fill the ultrasonic unit with enough water to cover the sample tubes and filler rods (if used). If too much detergent is used, it may be difficult to rinse from the sample tubes. Ensure the detergent is dissolved before placing the sample tubes and filler rods into the water.
4. Fill the sample tubes with warm water and place them in the ultrasonic cleaning unit, then place the filler rods in the unit. Turn on the ultrasonic cleaning unit for approximately 15 minutes.



5. Use rubber gloves to ensure no oils or residue are transferred to the clean tubes and filler rods, then remove the sample tubes and filler rods from the unit.
6. Clean the interior of the sample tubes with the brush supplied with the analyzer.
7. Rinse the sample tubes and filler rods thoroughly with hot water. Rinse again with isopropyl alcohol or acetone. If isopropyl alcohol or acetone is not available, deionized water may be used.



8. Stand the sample tubes on the sample tube rack and place the filler rods in a basket or in the rack. Bake in a vacuum oven for two hours at 110 °C.



Samples tubes can also be cleaned with high purity acetone or isopropyl alcohol and dried for about 10 minutes under heat. If using this method, continue with step 10.

9. Remove the sample tubes and filler rods from the oven and allow to cool.



Do not insert the filler rods at this time. Filler rods are inserted before the sample tube is installed on the analysis port.

10. Blow out the sample tubes with oil-free compressed air.
11. Rinse the sample tube closure with isopropyl alcohol, then wipe the sample tube closure dry with a clean, lint-free cloth.
12. Label the sample tube and stopper for identification.
13. Replace the rubber stopper.

CREATE THE SAMPLE FILE**See:**[*Create Sample Files on page 3 - 2*](#)

DETERMINE THE SAMPLE MASS



See also:

[Sample Data Worksheet for Gas Adsorption on page K - 2](#)

PHYSICAL ADSORPTION

Clean, dry sample tubes are essential for accurate results. How much sample to use can be determined best by experiment. In general, a sample providing 40 to 120 square meters of total surface area is recommended for nitrogen analysis. Less than 40 square meters may cause unreliable results. More than 120 square meters will extend analysis time.

Smaller quantities are required for samples having high surface areas. These samples require careful weighing after degassing because a small error may represent a considerable percent of total weight. Proper weighing techniques are most important in this case. Use no less than 100 mg to reduce the effect of weighing errors.

Care should be taken when loading powders — the accessory funnel is useful for this purpose. Large granules or chunks may be loaded with forceps.

Analysis results are expressed in units of surface area per gram of sample; therefore, it is important to know the true sample mass.

Follow the instructions on the *Sample Data Worksheet* and complete all fields to find the true sample mass.

1. Record the sample tube identification on the *Sample Data Worksheet*.
2. Place the sample weighing support on the balance. Tare the balance and allow it to stabilize at zero (0).
3. Place the empty sample tube set (empty sample tube and stopper) on the sample weighing support and place it on the balance.
4. Record the stabilized mass on the *Sample Data Worksheet*. Remove the sample tube set from the balance.



Do not touch the sample with bare hands while performing the following steps. Doing so could affect the accuracy of results.

5. Place a sample container on the balance. Tare the balance and allow it to stabilize to zero (0).
6. Slowly pour the specified amount of sample into the sample container.
7. Remove either the rubber stopper, Seal Frit, Check Seal, or TranSeal from the sample tube.

8. Use the sample tube funnel (provided in the accessories kit) and pour the sample from the weighing container into the sample tube.

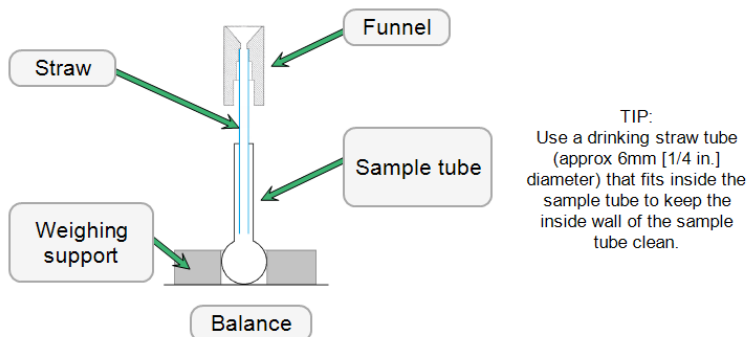

9. Replace either the rubber stopper, Seal Frit, Check Seal, or TranSeal.
10. On the *Sample Data Worksheet*, record the following:
 - a. Mass of the sample tube set with the sample.
 - b. Subtract the *Mass of empty sample tube set* from the *Mass of sample tube set plus sample*.

CHEMICAL ADSORPTION



See also:

[Use Quartz Filter Discs for Chemical Adsorption on the facing page](#)



Bulb sample tubes are for pellets and other samples without loose particles. Using powder samples in bulb tubes may cause the loose particles to go into the analyzer's exhaust.

1. Record the sample tube identification on the *Sample Data Worksheet*.
2. Place the sample weighing support on the balance. Tare the balance and allow it to stabilize at zero.
3. If analyzing a powder or sample made of fine particles, push a piece of quartz wool all the way down into the sample tube. See [Use Quartz Filter Discs for Chemical Adsorption on the facing page](#).
4. If using quartz wool, put a second piece of quartz wool just inside the sample tube. If using filter discs, push a filter disc down into the tube until it sits on top of the quartz wool. Place a second filter disc just inside the sample tube.
5. Place the sample tube set (sample tube with quartz wool or filter discs and stoppers) on the sample support. Record the stabilized mass on the *Sample Data Worksheet*.



6. Remove the sample weighing support and sample tube set from the balance.
7. Place the sample container on the balance and allow the balance to stabilize at zero.



Do not touch the sample with bare hands. Oil from hands could affect the accuracy of results.

8. Slowly add approximately 0.5 to 1.0 gram of sample to the sample container.
9. If a second piece of quartz wool or filter disc was inserted, remove the top portion of the quartz wool or the filter disc from the sample tube.
10. Use a funnel to slowly pour sample from the container into the sample tube on top of the quartz wool in the tube.



Ensure all sample in the container is placed in the sample tube to avoid errors caused by incorrect sample mass.

11. If using quartz wool, insert the top portion of quartz wool into the tube and press it down. If using filter discs, insert the filter disc into the tube and press it down.



Ensure the disc is flat on top of the sample. A seal must be created around the edge to prevent the sample from escaping.

12. Wipe the top of the sample tube with a lint-free cloth, such as a Kimwipe[®], to remove any quartz wool that may have adhered to the surface.
13. Weigh the sample tube set containing the sample and the stoppers. Record this mass as the *Sample + tube*.

Use Quartz Filter Discs for Chemical Adsorption



The equipment images in this topic may differ slightly from your equipment, however the instructions are the same unless otherwise noted.



The use of quartz wool is not mandatory, however it can provide extra protection for light powdered samples.



Wear latex gloves when handling the sample tube. The natural oils in human skin can chemically damage and weaken the quartz tube. It is also important that the sample tube and its components, as well as the sample and exhaust ports, be clean and free of debris. Dust particles from quartz wool or the insulator disc of previous analyses may adhere to the port and/or components, preventing a proper seal of the sample tube.

Use quartz filter discs or quartz wool to aid in chemical adsorption sample preparation. Quartz filter discs (placed both below and above powdered samples) not only provide a more uniform sample surface but also keep the analyzer free of sample debris. The filters can be used up to 900 °C.

1. Insert a small portion of quartz wool into the sample tube to serve as a support for the powdered sample. Use a filler rod or smaller sample tube to push the quartz wool to the bottom of the sample tube.

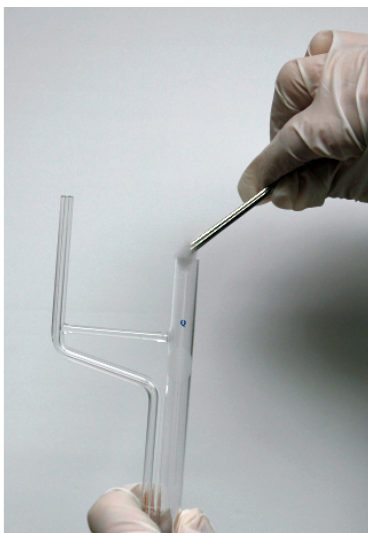

Insert quartz wool and disc

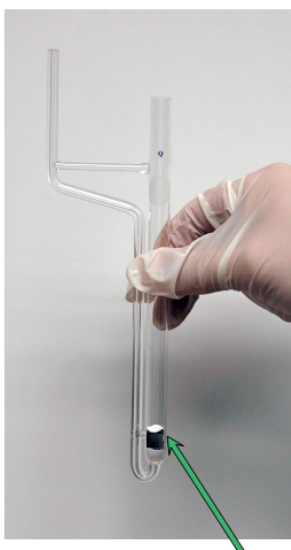

Top disc, powdered sample, bottom disc, quartz wool

2. Insert a quartz disc into the sample tube and push it into the tube until it rests on top of the quartz wool. Inspect the disc to ensure that there is a good seal and that the sample will not go past the filter. An additional filter can be inserted if needed.
3. Insert a second filter disc on top of the quartz wool. Ensure that the filter is placed high enough into the sample tube for easy retrieval.
4. Take the initial tube weight (with both filters).
5. Remove the top filter disc. Place it on a clean surface, then use a funnel to add the powdered sample on the bottom filter disc.
6. Reinsert the top filter disc into the sample tube, then use a rod or smaller sample tube to push it down until it reaches the top of the sample.
7. To remove the quartz wool and disc after analysis, use the quartz wool extractor tool.

DEGAS THE SAMPLE

Unit [n] > Start Degas

Most solid materials absorb moisture and other contaminants when exposed to the atmosphere. The sample must be clean before an analysis is performed. The degassing process involves heating the sample and placing it under vacuum to remove moisture and other contaminants.

Physical Adsorption

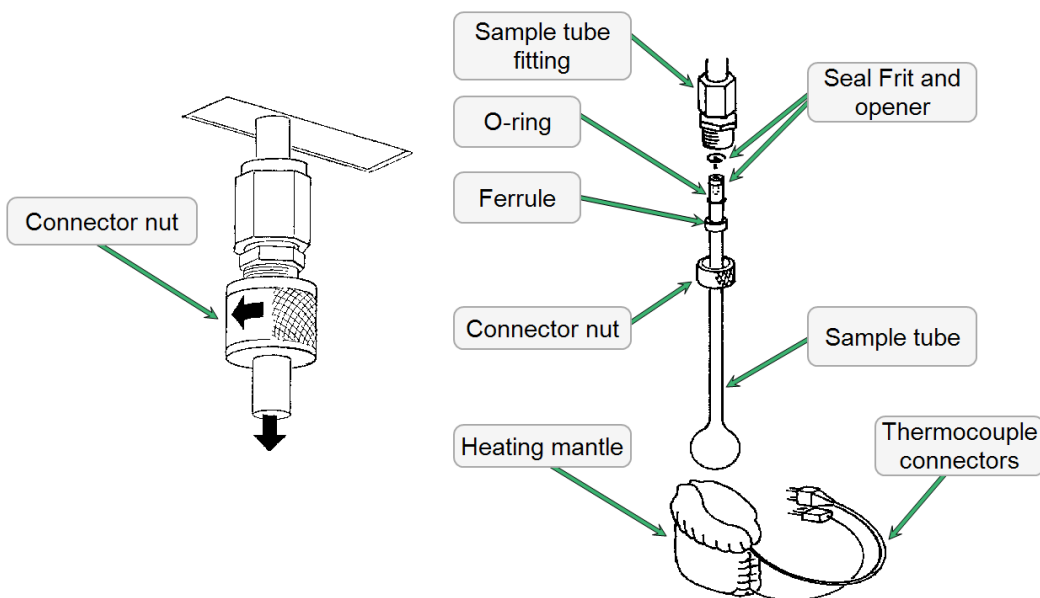

1. While holding the degas port plug, remove the connector nut and plug from the degas port by turning the connector nut counter-clockwise.
2. Place the degas port connector nut, ferrule, and O-ring onto the sample tube set.



The Seal Frit is for 1/2 in. sample tubes only. When using a 1/4 in. or 3/8 in. sample tube, the Seal Frit opener must be removed from the sample connector

3. Remove the rubber stopper from the sample tube and attach the sample tube set to the degas port.
4. Push the sample tube in to a full stop.



Mounting the sample tube at an angle might break the tube and cause injury.

5. Secure the sample tube in place by sliding the connector nut, ferrule, and O-ring up to the degas port and turning the connector nut clockwise.
6. Tighten the connector nut securely by hand.



Never use a tool to tighten the nut; doing so may cause the sample tube to break.

7. Place a heating mantle over the sample tube bulb and secure the mantle in place with a mantle clip.
8. Securely insert the heating mantle thermocouple plug and thermocouple power plug into the thermocouple outlets on the analyzer.
9. Degas the sample.
10. After degassing, transfer the sample tube to the analysis port. See [Transfer a Degassed Physical Adsorption Sample to an Analysis Port on page 5 - 2](#).

Chemical Adsorption

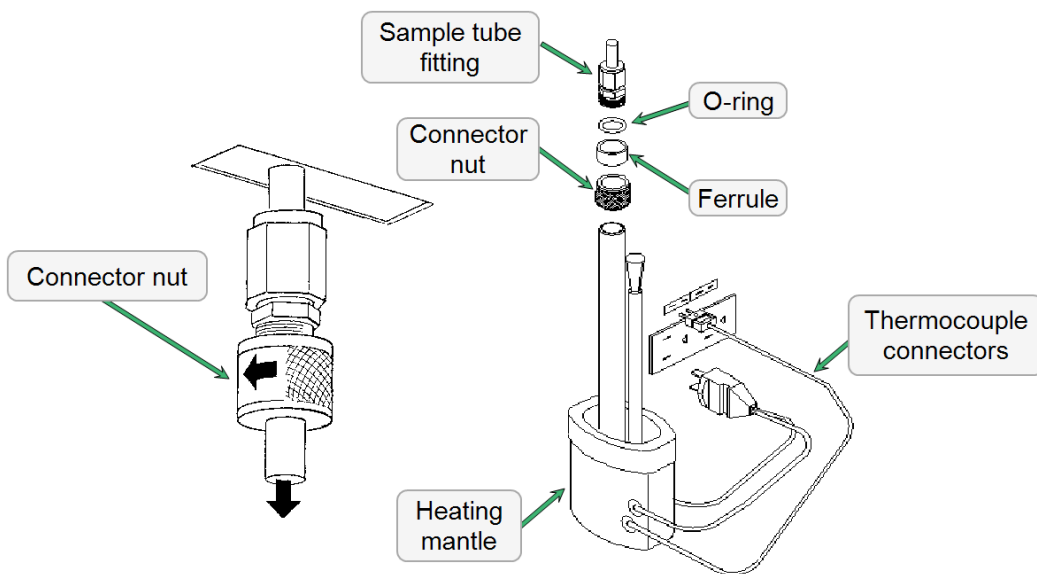

1. While holding the degas port plug, remove the connector nut and plug from the degas port by turning the connector nut counter-clockwise.
2. Place the degas port connector nut, ferrule, and O-ring onto the sample tube set.
3. Remove the rubber stopper from the sample tube and attach the sample tube set to the degas port.
4. Push the sample tube in to a full stop.



Mounting the sample tube at an angle might break the tube and cause injury.

5. Secure the sample tube in place by sliding the connector nut, ferrule, and O-ring up to the degas port and turning the connector nut clockwise.
6. Tighten the connector nut securely by hand.



Never use a tool to tighten the nut; doing so may cause the sample tube to break.

7. Ensure the exhaust tube of the sample tube has been capped.
8. Place a heating mantle over the sample tube bulb and secure the mantle in place with a mantle clip.
9. Securely insert the heating mantle thermocouple plug and thermocouple power plug into the thermocouple outlets on the analyzer.
10. Degas the sample.

SAMPLE TUBE INSTALLATION

PHYSICAL ADSORPTION

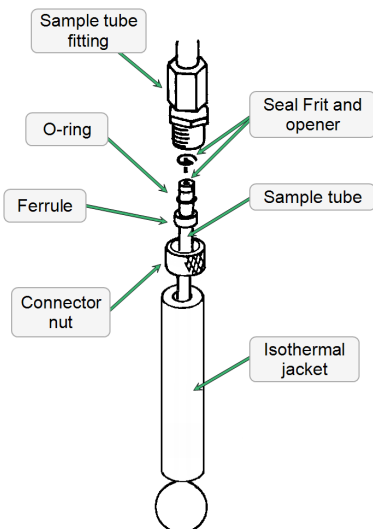

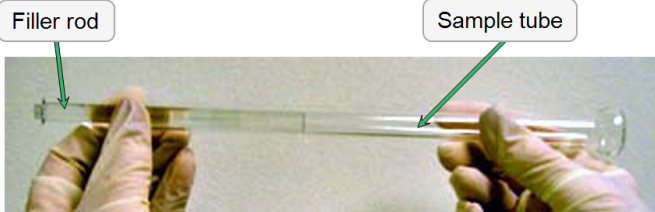
If using...	Then...
A rubber stopper	Remove it.
An isothermal jacket	Slide the jacket down over the stem of the sample tube until it touches the sample tube bulb.
A filler rod	<p>Hold the sample tube horizontally and carefully slide the filler rod into the tube.</p> <div style="text-align: center;">  </div> <div style="border: 1px solid black; padding: 5px; margin-top: 10px;"> <p>CAUTION Do not hold the rod vertically and drop the rod into the tube; this could break the rod and/or tube.</p> </div>

1. Loosen the connector nut on the P₀ tube and rotate the P₀ tube out of the way.
2. If using a TranSeal and/or isothermal jacket, install it.
3. Place the connector nut, ferrule, and O-ring onto the sample tube stem.

4. Insert the sample tube into the analysis port and ensure it is completely in the port. Securely hand tighten the connector nut onto the analysis port.
5. Position the dewar cover approximately 3/4 in (19 mm) below the connector nut.

CHEMICAL ADSORPTION



Wear latex gloves when handling the sample tube. The natural oils in human skin can chemically damage and weaken the quartz tube. It is also important that the sample tube and its components, as well as the sample and exhaust ports, be clean and free of debris. Dust particles from quartz wool or the insulator disc of previous analyses may adhere to the port and/or components, preventing a proper seal of the sample tube.

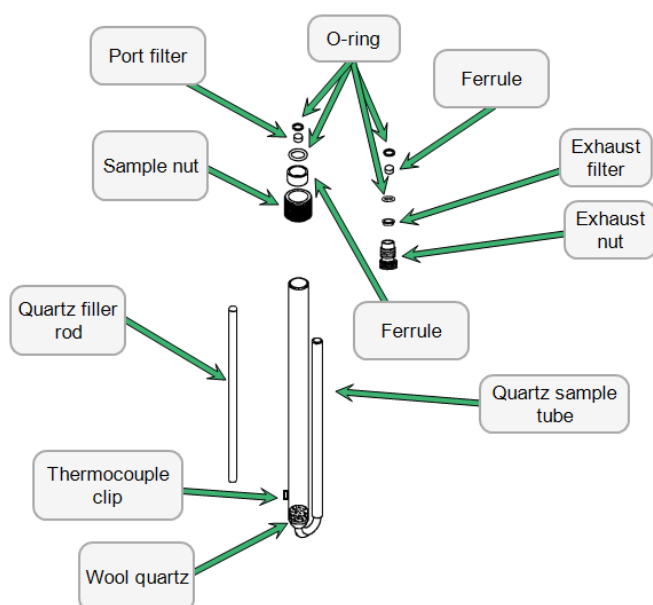

1. Use a lint-free swab moistened with IPA and wipe the interior rims of the sample and exhaust ports.
2. Use a lint-free tissue moistened with IPA and wipe the O-ring, ferrule, and connector nuts for the sample and exhaust tubes. Place on a lint-free tissue.



Sample and exhaust ports, as well as all components that contact the sample and exhaust ports, must be clean, therefore it is recommended that the previous steps be repeated each time a sample tube is installed onto a port

3. If using a hanging filler rod (recommended), hold the sample tube slightly tilted and carefully place the filler rod into the tube.
4. Assemble and install the sample and exhaust tube components.
5. Insert the assembled sample tube into the exhaust port.

6. Slide the connector nuts up the stems and screw the nuts clockwise to secure the tube in place. Hand tighten both connector nuts until snug.
7. Insert the temperature thermocouple into the thermocouple clip on the sample tube.
8. Ensure the furnace is on the elevator shelf and manually raise the elevator using the instrument schematic. On the schematic, right click the furnace icon and select *Raise* to raise the elevator. If it is necessary to stop the elevator, right click the elevator icon again and select *Stop*.

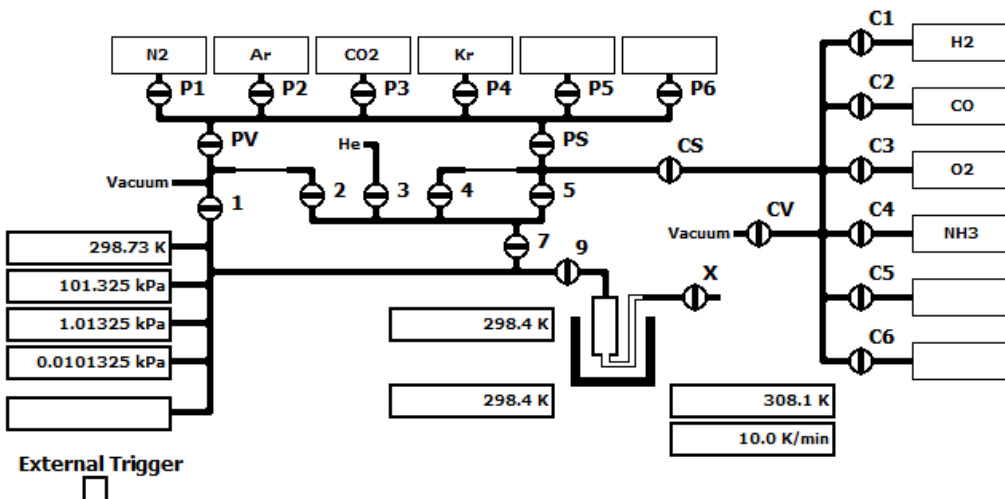

8. When the elevator reaches the top, insert the two furnace disk halves on top of the furnace opening. Place the first disk behind the sample tube and the second disk in front of the sample tube. Ensure the clip remains above the furnace disks.
9. Install the safety shield to cover the furnace.

FILL AND INSTALL THE DEWAR



The equipment images in this topic may differ slightly from your equipment, however the instructions are the same unless otherwise noted.



See also:

[Dewar Precautions on page 6 - 1](#)



1. Fill the dewar with the analysis bath liquid (such as liquid nitrogen) to no higher than 2 1/4 in. (5.7 cm) from the top. Filling the dewar higher than this will cause an error in the free space measurement.



Incorrect fluid levels can lead to measurement errors. Check the level of the bath liquid before each analysis.

2. Insert the dipstick and check the level of the analysis bath liquid. Condensation should not exceed the level indicator mark.



Wetness or frozen condensation indicates bath liquid level

Level indicator mark

3. For best results, if the dewar has not been used for a while, allow approximately 30 minutes for the temperature of the dewar to stabilize with the bath liquid, then recheck the level of the bath liquid. Add additional liquid if necessary.
4. Slide the dewar cover to ensure a proper seal on the top of the dewar.
5. Place the dewar on the elevator.

PERFORM A SAMPLE ANALYSIS

Unit [n] > Sample Analysis

Sample Stage	Last Point	p (kPa)	p/p ^o	Q (mmol/g)	p ^o (kPa)	Run Time
Idle	0	0.0000000	0.1035915	0.00000	101.3250	0:00



P Use caution when removing the sample tube if using a hanging filler rod. The sample tube O-ring or dewar cover may snag the filler rod retaining ring. Loosen the snag gently; excessive force may break the tip of the filler rod.

Sample Analysis

Field or Button	Description
Density / Mass / Sample + Tube / Empty Tube [text box]	Enter values for the sample's mass and density. These values may be edited after analysis.
New [button]	Creates a new sample file.
	For fields and buttons not listed in this table, see Common Fields and Buttons on page 2 - 3 .

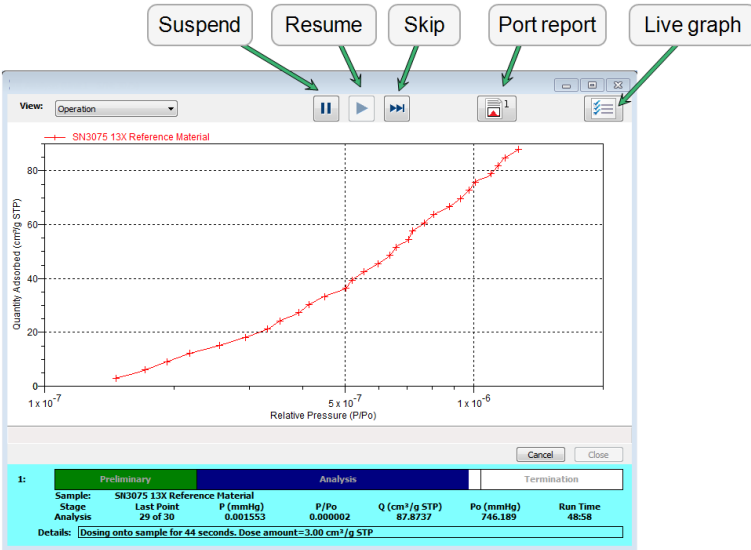

Sample Analysis Graph

Field or Button	Description
Live Graph Settings [button]	Select Thermal transpiration, x-axis Quantity (relative or absolute pressure), and the x-axis Scale (linear or logarithmic).
Report after analysis [button]	Generates reports to the selected destination when the analysis is complete.
Port [button]	Generates a report on data being collected. The reports are displayed on the computer monitor only.
Resume [button]	Restarts the suspended analysis.
Skip [button]	Moves to the next step. Select the ports to skip.
Status window	Displays the last point pressure and relative pressure for each port.
Suspend [button]	Suspends an analysis in progress.



For fields and buttons not listed in this table, see [Common Fields and Buttons on page 2 - 3](#).

PERFORM AN ANALYSIS SEQUENCE FOR CHEMICAL ADSORPTION

Unit [n] > Analysis Sequence



See also:

[Use Quartz Filter Discs for Chemical Adsorption on page 6 - 11](#)

Use to perform a sequence of analyses. If the *Analysis Sequence* option is selected and a sequence analysis is already in progress, the program continues to run the four steps for the analysis in progress. Files can be added and removed from the sequence while it is in progress.



Sample files must be created prior to performing an analysis sequence. See [Sample Files on page 3 - 1](#).



Ensure the furnace is raised to its uppermost position otherwise hazardous conditions can result.

Operator intervention will be required between analyses in the sequence if the temperature control type changes. Intervention will be required if at the beginning of the analysis.

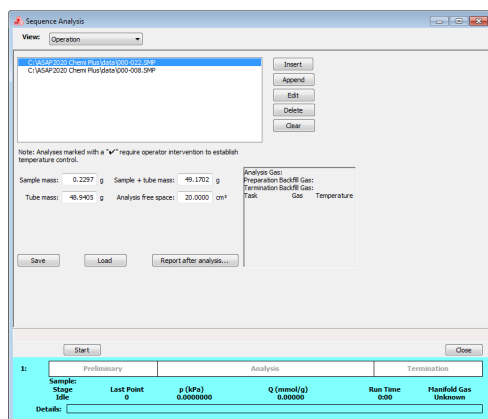

Use caution when removing the sample tube if using a hanging filler rod. The sample tube O-ring or dewar cover may snag the filler rod retaining ring. Loosen the snag gently; excessive force may break the tip of the filler rod.

Analysis Sequence

Field or Button	Description
Analysis free space <i>[text box]</i>	Free space used for analysis.
Report after analysis <i>[button]</i>	Generates reports to the selected destination when the analysis is complete.
Sample + tube mass <i>[text box]</i>	Sample tube weight plus sample weight.
Sample mass <i>[text box]</i>	Sample weight.
Tube mass <i>[text box]</i>	Sample tube weight.

 For fields and buttons not listed in this table, see [Common Fields and Buttons on page 2 - 3](#).

7 ABOUT REPORTS

Reports > Open Report > [.REP file]

Opens a saved report.

Reports > Close Reports

Closes all open reports. This option is unavailable if reports are being generated.

Reports > Start Report

Generates a report on a sample analysis.

Reports can be generated for data collected on a sample that has completed analysis, collected on a sample currently being analyzed, or manually entered.

HEAT OF ADSORPTION REPORT

Reports > Heat of Adsorption

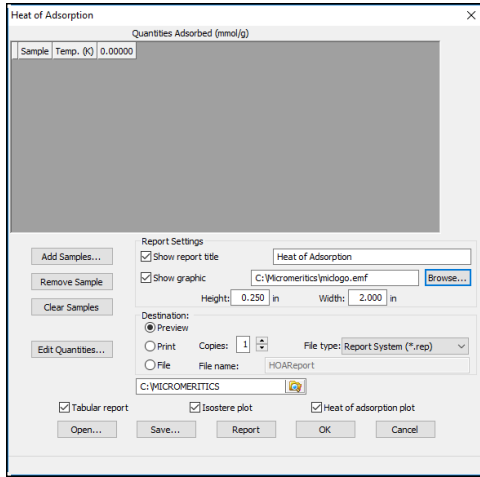

Use to select sample files, define quantities, and generate a *Heat of Adsorption* report. The isosteric heat of adsorption is an important parameter for characterizing the surface heterogeneity and for providing information about the adsorbent and the adsorption capacity. Multiple adsorption isotherms are obtained on the same sample using the same adsorptive but at different temperatures to obtain the heat of adsorption.

Heat of Adsorption Report

Field or Button	Description
Add Samples [button]	Adds a sample file to the table.
Clear Samples [button]	Removes all entries from the table.
Edit Quantities [button]	Use to specify the range of surface coverage to include in the report.

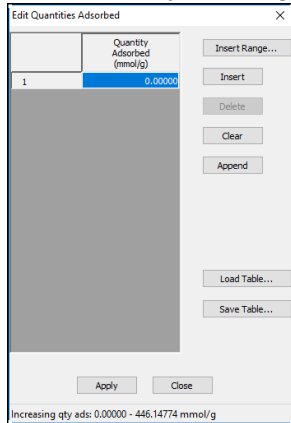

Heat of Adsorption Report (continued)

Field or Button	Description
	<p>Insert Range. Click to specify the starting and ending quantities adsorbed and number of points to insert.</p> <p>Load Table. Imports values from another file.</p> <p>Save Table. Saves the current table as a .QNT file.</p> <p>Apply. Applies all table changes.</p>
Heat of adsorption plot [selection]	Generates the <i>Heat of Adsorption</i> data in a graphical format.
Isostere plot [selection]	Generates a graph showing quantities of gas adsorbed versus the temperature.
Remove Sample [button]	Removes the selected sample from the list.
Show graphic [checkbox]	Use to show a graphic on the report header. Height/Width. Enter the height and width of the selected graphic. These values determine the graphic appearance on the generated report.
Show report title [checkbox]	Select and enter a report title to appear on the report header.
Tabular report [checkbox]	Generates a tabular report of the included samples. A tabular report contains the numeric values contributed by each sample.
	For fields and buttons not listed in this table, see Common Fields and Buttons on page 2 - 3 .

SPC REPORT FOR PHYSICAL ADSORPTION

Use to generate reports with various SPC (Statistical Process Control) options. All selected variables must be computed for each sample file used in an SPC report; therefore, it is more efficient to select only the necessary variables.

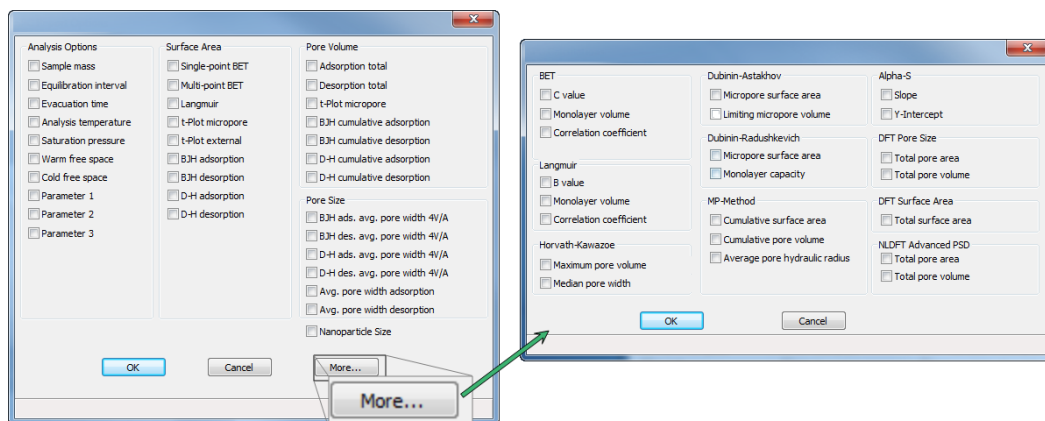

The selected items display as graph variable selections in **Reports > Regression Report** and graph selections in **Reports > Control Chart**. If report options for NLDFT Advanced PSD are required, click [More](#).

REGRESSION REPORT FOR PHYSICAL ADSORPTION

Reports > Regression Report

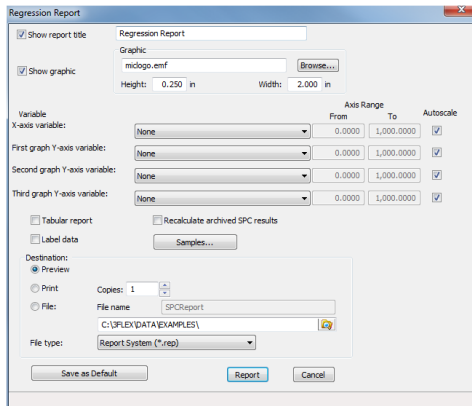

Use to generate a Statistical Process Control (SPC) Regression report to determine the interdependency between two variables. Up to three dependent variables (y-axis) may be plotted against a single independent variable (x-axis). The degree of correlation between the variables is also reported.



Regression Report

Field or Button	Description
Autoscale [checkbox]	When enabled, allows the x- and y-axes to be scaled automatically.
Axis Range [text box]	Enter the beginning and ending values for the x- and y-axis ranges. These fields are disabled if <i>Autoscale</i> is selected.
Label data [checkbox]	Use to label the points on the plot to correspond with the values in the sample files.
Recalculate archived SPC results [checkbox]	Use to have archived SPC values recalculated ensuring any changes made to the SPC Report Options are included in the new report. This option lengthens the time required to generate the report. <div style="border: 1px solid green; padding: 5px; margin: 5px 0;"> If this recalculation option is enabled and sample files from an earlier application version are selected, it is recommended that copies of the archived sample files be used rather than the original. Selecting this option will make some archived sample files unreadable by the original application. If an earlier application version will not be reused, this warning message can be safely disregarded. </div>
	When this option is selected, this message will display:

Regression Report (continued)

Field or Button	Description
	<p>Saving the recalculated SPC data may render some files unreadable by the original application. Saving the SPC data speeds up future SPC reports.</p> <hr/> <p> If <i>Do not show me this message again</i> is selected, the message cannot be redisplayed without Micromeritics assistance.</p> <hr/> <p>The first time this option is used, the time it takes to generate the report is lengthened. The second time the report is generated, if using the same sample files used in the initial calculation, it is recommended that this option not be selected since the data was recalculated previously. If a sample file is added or removed from the report after the initial recalculation, this option should be selected again to ensure the data from the newly added or removed sample file is recalculated.</p>
Samples [button]	Select additional sample files to add to the report.
Save as Default [button]	Click to save selected report options as default report settings.
Show graphic [checkbox]	Use to show a graphic on the report header. Height/Width. Enter the height and width of the selected graphic. These values determine the graphic appearance on the generated report.
Show report title [checkbox]	Select and enter a report title to appear on the report header.
Tabular report [checkbox]	Generates a tabular report of the included samples. A tabular report contains the numeric values contributed by each sample.
X- and Y-Axis Variable [drop-down box]	Use to designate the x- and y-axes variables. The variables in the drop-down lists are those selected in the Reports > SPC Report Options window. Use these options to plot the regression of up to three y-axis variables against the x-axis variable.
	For fields and buttons not listed in this table, see Common Fields and Buttons on page 2 - 3.

CONTROL CHART REPORT FOR PHYSICAL ADSORPTION

Reports > Control Chart

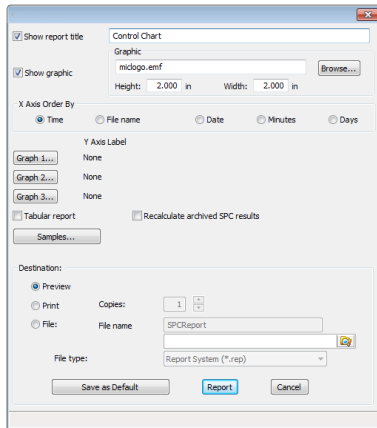

Generates a Statistical Process Control (SPC) chart report which plots the changes in a statistic.

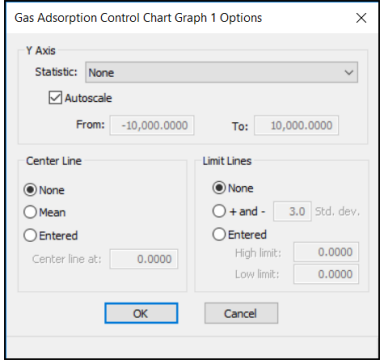

Control Chart Report

Field or Button	Description
Graph [n] [button]	<p>Defines the y-axis of each graph.</p>  <p>Statistic. Displays the SPC variables selected on the Reports > SPC Report Options window. The selected variable will be plotted for each selected sample. This selection also becomes the y-axis label.</p> <p>Autoscale. Allows the y-axis to be scaled automatically. To specify a range, deselect this option and enter a range in the <i>From</i> and <i>To</i> fields.</p> <p>Center Line. Displays placement options for the center line in the graph. Select <i>Entered</i> to specify placement of the line or <i>Mean</i> to place</p>

Control Chart Report (continued)

Field or Button	Description
	<p>the center line at the calculated mean value for the selected samples.</p> <p>Limit Lines. Displays limiting lines options. Lines can be placed at some multiple of the standard deviation or at specified positions (<i>Entered</i>). When <i>Entered</i> is selected, enter the <i>High limit</i> and <i>Low limit</i> fields with appropriate values.</p>
<p>Recalculate archived SPC results <i>[check box]</i></p>	<p>Use to have archived SPC values recalculated ensuring any changes made to the SPC Report Options are included in the new report. This option lengthens the time required to generate the report.</p> <hr/> <div style="display: flex; align-items: flex-start;">  <div> <p>If this recalculation option is enabled and sample files from an earlier application version are selected, it is recommended that copies of the archived sample files be used rather than the original. Selecting this option will make some archived sample files unreadable by the original application. If an earlier application version will not be reused, this warning message can be safely disregarded.</p> </div> </div> <hr/> <p>When this option is selected, this message will display:</p> <div style="background-color: #f0f0f0; padding: 5px; margin: 5px 0;"> <p>Saving the recalculated SPC data may render some files unreadable by the original application. Saving the SPC data speeds up future SPC reports.</p> </div> <hr/> <div style="display: flex; align-items: flex-start;">  <div> <p>If <i>Do not show me this message again</i> is selected, the message cannot be redisplayed without Micromeritics assistance.</p> </div> </div> <hr/> <p>The first time this option is used, the time it takes to generate the report is lengthened. The second time the report is generated, if using the same sample files used in the initial calculation, it is recommended that this option not be selected since the data was recalculated previously. If a sample file is added or removed from the report after the initial recalculation, this option should be selected again to ensure the data from the newly added or removed sample file is recalculated.</p>
<p>Report <i>[button]</i></p>	<p>Generates the report.</p>
<p>Samples <i>[button]</i></p>	<p>Select additional sample files to add to the report.</p>

Control Chart Report (continued)

Field or Button	Description
Show graphic <i>[check box]</i>	Use to show a graphic on the report header. Height/Width. Enter the height and width of the selected graphic. These values determine the graphic appearance on the generated report.
Show report title <i>[check box]</i>	Select and enter a report title to appear on the report header.
Tabular report <i>[check box]</i>	Generates a tabular report of the included samples. A tabular report contains the numeric values contributed by each sample.
X Axis Order by <i>[group box]</i>	Select the order in which x-axis statistics are placed. Sort by: Time. Time the files were analyzed. File name. Alphanumeric order. Date. Date the files were analyzed. Minutes. Minutes elapsed from the first file placed on the list, which is the earliest-analyzed file. Days. Number of days elapsed from the first file placed on the list, which is the earliest-analyzed file.
	For fields and buttons not listed in this table, see Common Fields and Buttons on page 2 - 3 .

INTERACTIVE REPORTS

When opening a sample file that contains data from a complete or in-progress analysis, the interactive reporting feature is enabled.

- When opening a sample file that contains analysis data, a window with the following information will display:
 - a linear plot and log plot of the data collected during analysis
 - a summary of the analysis giving a single total pore volume and surface area

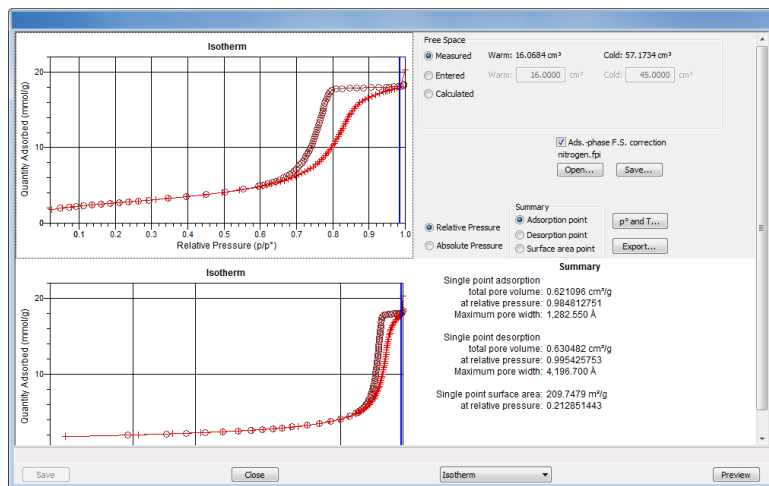

- To view the plots in either relative or absolute pressure, select either the *Relative Pressure* or *Absolute Pressure* option.
- To view the reports selected for generation during the analysis, click **Preview**.
- From the drop-down list at the bottom of the window:
 - change the option presentation of the sample information window to either *Basic* or *Advanced* to modify certain file parameters, or
 - select another plot from the list and edit the data contained in the plot.
- When ranges are edited, the changes are reflected immediately in the plots and the summary data displayed in the window. Some editing options are:
 - Drag the blue bars to increase or decrease the range of data included in the plot.
 - Edit the Isotherm Linear Plot to include or omit the data point from the BET plot.
 - Right click to display a popup menu to include reports; enable or select overlays; edit curves, axes, legends, titles; and copy and paste the data in a graph or in tabular format.
- Click **Save**.

MICROACTIVE REPORTS

MicroActive reports are generated automatically after an analysis is performed. This feature provides a quick and easy way to investigate and manipulate analysis data using a variety of reporting methods.

When a sample file with a status of *Complete*, *Analyzing* or *Entered* is opened, a linear plot and log plot of the data collected during analysis are displayed as well as a summary of the analysis giving the total pore volume. Numerous reports are accessible from a drop-down menu.

When a report is opened, plots and summary data are displayed, and in some reports certain parameters (for example, thickness curve type, pore geometry, and interaction parameters) are also displayed. Plots may be edited by selecting the data points or data point range to be included in the plots and modifying the parameters. When a report is edited, the results are immediately reflected in the plots and summary data.

Log in to your [customer portal](#) to access MicroActive Report Tutorials.

EVALUATE REPORT RESULTS

Analysis reports provide a record of test conditions, experimental data, and information extracted from the experimental data by application of various reduction methods. This topic discusses the elements of various reports presented by Micromeritics' static volumetric physical adsorption analyzers and suggests ways by which the merit of the reported information may be evaluated.

Regardless of the precautions exercised before the analysis, problems still may occur during the analysis, or as a result of using inappropriate parameters or even inappropriate methods. The analysis data should be inspected for evidence of experimental error. The traditional method of confirming the quality of the experiment is to repeat the analysis. Toward that end, Micromeritics' analyzers log and report the exact conditions of each analysis.

Analysis data can be evaluated by:

- Viewing the Validation Report
- Inspecting the Isotherm Plot
- Evaluating the Isotherm Tabular Data Set
- Reviewing Reduced Data

VIEW THE VALIDATION REPORT

The *Validation* report shows whether the data collected during an analysis are within typical ranges. Select the types of reports to include by selecting the report in the *Validation Report Options* window.

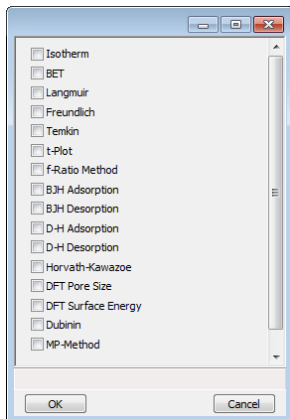

When a selected report is generated, if errors occur, a message is displayed across the top portion of the report and a unique symbol displays on the graph.

INSPECT THE ISOTHERM PLOT

Evaluation of data should begin with a visual inspection of the isotherm plot. The plot should be composed of data which have not been subjected to mathematical smoothing as far as possible. If the data describe a Type I isotherm, then the plot is best shown on a logarithmic pressure axis so that details of the low pressure region are revealed. Data in this region are important particularly for micropore studies. Examine the plot to determine if any points are outliers or if a region of the isotherm exhibits characteristics (spikes, steps, etc.) which are inconsistent with the physical process being monitored. The philosophical question of whether or not these suspected extraneous data points should be removed from the raw data is not considered here, but it may be appropriate to exclude an outlier from reduced data. Too many outliers can cause the integrity of the total data set to come under suspicion.

Examine specific reported values to confirm that the isotherm data were collected under reasonable conditions and using reasonable parameters. For example, confirm that the free space values reported are typical for the sample holder and bath in use. A problem with either ambient or analysis free space values may indicate a free space measurement error and affect all calculations of quantity adsorbed.

The raw data should be carefully examined before it is reduced. Errors that occur in raw data will only be exacerbated in reduced data.¹⁾

¹⁾ The information in this article is extracted from *Analytical Methods in Fine Particle Technology*, Webb, P. and Orr, C., (1997).

EVALUATE THE ISOTHERM TABULAR DATA SET

Another place to look for reasonableness of the data is the adsorptive uptake by the sample in the BET range ($P/P_0 = 0.05$ to 0.30). Total uptake is the specific quantity adsorbed ($\text{cm}^3/\text{g STP}$) times the sample mass (g). As an example, the level of uncertainty in this range typically is less than $0.1 \text{ cm}^3 \text{ STP}$ for a high performance system. Total uptake quantities should be some multiple of this level of uncertainty. Otherwise, an unfavorable signal-to-noise ratio and unreliable data result. The solution is to use a greater quantity of sample to increase adsorptive uptake.

Another valuable bit of information resides in the tabulated saturation pressure. This pressure is expected to change somewhat over the duration of an analysis, but it is not expected to do so with large or abrupt transitions. Unreasonable saturation pressures or unusual changes may indicate that a gas different from the adsorptive was used in determining P_0 , that the level of the cryogen fell too far, or that the cryogen is impure or inappropriate.

With experience, obvious signs of problems can be detected by a quick inspection of the tabular and graphical data. If the data appear satisfactory, the next step is to evaluate the reduced data.¹⁾

REVIEW REDUCED DATA

Isotherm data may be analyzed by any one of several reduction methods depending on the analyzer model and pressure range employed. The quality of the results depends on the quality of the isotherm, the congruity of the data reduction parameters with experimental conditions, the agreement of the theoretical model with the physical gas-solid system, and compliance to the pressure range over which the method is valid. Typically, results can be appraised by examining a few salient areas of the report as described in the following topics.²⁾

PHYSICAL PARAMETERS

The value of physical parameters which are used only in data reduction routines should be reviewed to assure that they agree with experimental conditions. These parameters can be changed and the experimental data recalculated if an error is discovered or if exploring an alternate value is desired. Analysis condition values used in the calculation of quantity adsorbed can be changed also. These are typically the manually entered free space(s), nonideality correction factor, and bath temperature.

¹⁾ Most of the information in this article is extracted from Analytical Methods in Fine Particle Technology, Webb, P. and Orr, C., (1997).

²⁾ Most of the information in this article is extracted from Analytical Methods in Fine Particle Technology, Webb, P. and Orr, C., (1997).

The area occupied by a single adsorbed molecule is a required parameter in the calculation of surface area by the BET and Langmuir methods. The software provides a default value, but other values are found in the literature. McClellan and Harnsberger¹⁾ provide a comprehensive review of such values.

The volume of pores of a specific size range is calculated from the gas quantity adsorbed in them by converting the quantity to its liquid equivalent volume. This is achieved through use of a density conversion factor calculated from the ratio of molar densities of the condensed adsorbate at bath temperature to the gaseous phase at STP. The necessary information is found in handbooks. The software contains default values for common adsorptives; values for other adsorptives must be calculated.

The terms for liquid surface tension γ , contact angle between solid and liquid phase θ , molar volume of the adsorbate n , gas constant R , and sample temperature T are treated as one constant, the adsorbate property factor A expressed by:

$$A = \frac{2\gamma n \cos \theta}{RT}$$

using which, the Kelvin equation²⁾ reduces to

$$\ln \frac{P^*}{P_o} = \frac{A}{r_m}$$

Either surface tension, contact angle, or molar volume can be revised individually to give a new value for the factor A , or A can simply be altered arbitrarily for exploratory purposes.

The thermal transpiration correction requires two parameters which may be adjusted from those of the default values. The first is the inside stem (neck) diameter of the sample holder, and the second is the hard-sphere diameter of the adsorptive molecule. The sample holder inside diameter is available from the documentation provided with it or is measurable. Information on hard-sphere diameters of molecules may be obtained from handbooks.

For terms such as the interaction parameter found in the Horvath-Kawazoe calculation³⁾, the Dubinin affinity coefficient, or Astakhov exponent⁴⁾, the default values as provided by the software generally are adequate. A search of the technical literature is required if the analysis involves a gas-solid system other than that covered by the default values.

1) McClellan, A.L., and Harnsberger, H.F., Journal of Colloid and Interface Science, 23, 577 (1967).

2) Thomson, W., Phil. Mag. S., 42, 448 (1871).

3) Everett, D.H. and Powl, J.C., J. Chem Soc., Faraday Trans. 1, 72, 619 (1976).

4) Dubinin, M. and Radushkevich, L.V., Proc. Acad. Sci. USSR, 55, 331 (1947).

The t-Plot method plots quantity adsorbed (V_a) against thickness (t) derived from a thickness equation, and the Dubinin transform plots quantity adsorbed against $\log(P/P_0)^n$. All of these data reduction methods were first proposed for specific applications. The user must make a judgment as to the applicability of the method to a gas-solid system.

If applied appropriately, all transform plots will exhibit a linear range and the regression analysis must be applied only over the linear range and within the range of application. Fitting a regression line to surface area transformation plots should yield a correlation coefficient of 0.9999 or better and for t-plots and Dubinin plots the correlation coefficient should be 0.99 or better.

If the data reduction model does not apply to the gas-solid system under examination, then it may be that either no linear range exists within the pressure range of validity, or that solutions derived from the regression line of the linear range are intuitively incorrect, that is, they have no relevance to the physical situation, such as a negative C-value from a BET transform.

BET C-VALUE

BET theory assumes uniform surface coverage with no favored adsorption sites and it also assumes that the gas is more strongly attracted to the surface than to other gas molecules. The typical range of BET C-values is from about 5 to well over 100. Values much less than 5 imply that the gas-to-gas affinity is competing with the gas-to-solid affinity which conflicts with the basic assumptions of BET theory. C-values much greater than 100 indicate very strong attraction for the surface or preferential adsorption.

Provided the isotherm was determined with negligible error and the regression line to the BET transformation data was fit properly, then an out-of-range C-value probably indicates that the gas-solid interaction for the particular sample material does not conform to the BET model. An inappropriate adsorption model may be indicated also by the coefficient of correlation of the regression line, 0.999 being about the minimum value expected with five more or less equally spaced points. In the case of indications of poor conformance to the BET model, the Langmuir data reduction method should be examined.

DATA ANALYSES BY THE BJH METHOD

In general, this method visualizes the incremental decomposition of an experimental isotherm, starting at the highest relative pressure or pore size. At each step the quantity of adsorptive involved is divided between pore-emptying and film-thinning processes and is accounted for totally. This computational algorithm frequently leads to inconsistencies when carried to small mesopore sizes. If the thickness curve used is too steep, ultimately it will predict a larger increment of adsorptive for a given pressure increment than is actually observed. The algorithm must stop since a negative pore volume is nonphysical. Accumulated error results in the calculation of a too large volume of (possibly nonexistent) small pores if the thickness curve used underestimates film thinning.

REPORT FEATURES AND SHORTCUTS

Reports can be customized and manipulated using the toolbar, shortcut menus, the zoom feature, or axis cross-hairs.

- After analysis, reports can be viewed, printed, and/or copied and pasted into other documents.
- The report zoom feature provides the viewing of fine graph details and the ability to shift the axes.
- All reports contain a header displaying file statistics.

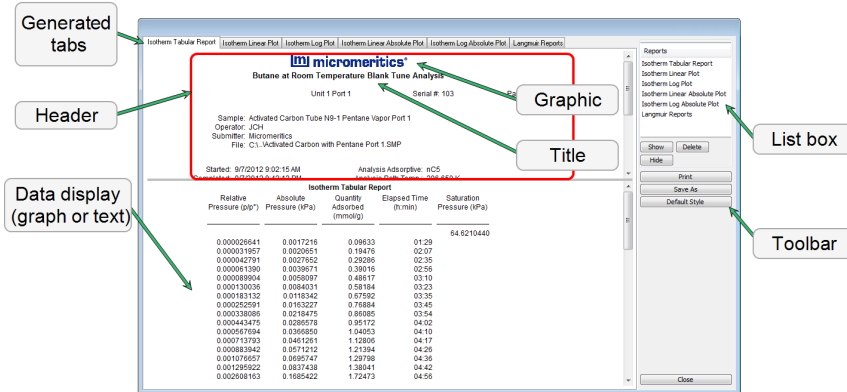

The screenshot shows a report window titled "micromeritics® Butane at Room Temperature Blank Turn Analysis". The window is annotated with callouts for various features:

- Generated tabs:** Located at the top left, pointing to the report title bar.
- Header:** Points to the text area containing sample and analysis information.
- Data display (graph or text):** Points to the table of data at the bottom of the report.
- Graphic:** Points to a small graphic element in the header.
- Title:** Points to the main title of the report.
- List box:** Points to a list of report types on the right side of the window.
- Toolbar:** Points to a set of control buttons (Show, Delete, Hide, Print, Save As, Default Style, Close) on the right side.

Relative Pressure (ppb)	Absolute Pressure (PPa)	Quantity Adjusted (mmol/g)	Elapsed Time (h:min)	Saturation Pressure (PPa)
0.00026641	0.0017216	0.09833	01:29	64.6210440
0.00031967	0.0020951	0.18476	02:07	
0.00042791	0.0027852	0.29285	02:35	
0.00051300	0.0036974	0.39015	02:56	
0.00089904	0.0058097	0.48817	03:10	
0.00138105	0.0084831	0.58184	03:23	
0.00183132	0.0118342	0.67592	03:35	
0.00252591	0.0163227	0.76884	03:45	
0.00333695	0.0218476	0.86065	03:54	
0.00443475	0.0289578	0.95172	04:02	
0.00597684	0.0386650	1.04203	04:10	
0.00713793	0.0481261	1.12805	04:17	
0.00883942	0.0571512	1.21294	04:25	
0.01076657	0.0695747	1.29798	04:36	
0.01289522	0.0837438	1.38041	04:42	
0.02068163	0.1665422	1.72473	04:56	

If configured, the report header can also contain a graphic and/or a title.

- Tabular and graphical reports contain sample and analyzer statistics such as analysis date/time, analysis conditions, etc.
- The headers contain notes of sample file changes occurring after analysis.
- Summary report headers contain the same information as tabular and graphical reports with the exception of notes.

REPORT HEADER SHORTCUTS

Display header shortcuts by right clicking in the report header.

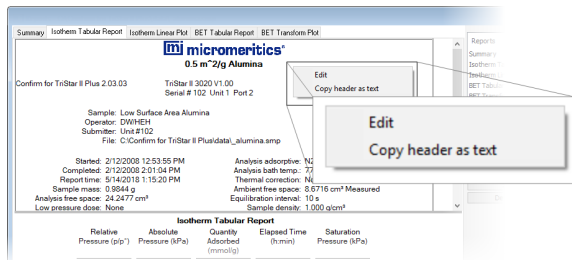

Report Header Shortcuts

Field or Button	Description
Copy header as text	Use to copy the report header as text. Text is copied to the clipboard and then can be pasted into other documents.
Edit	Use to edit the report title and/or graphic in the report header.

REPORT TOOLBAR

The *Report* window has a toolbar on the right portion of the window and selectable tabs at the top of the report header. To view a specific report, either select the tab or the report in the *Reports* list box, then click **Show**.

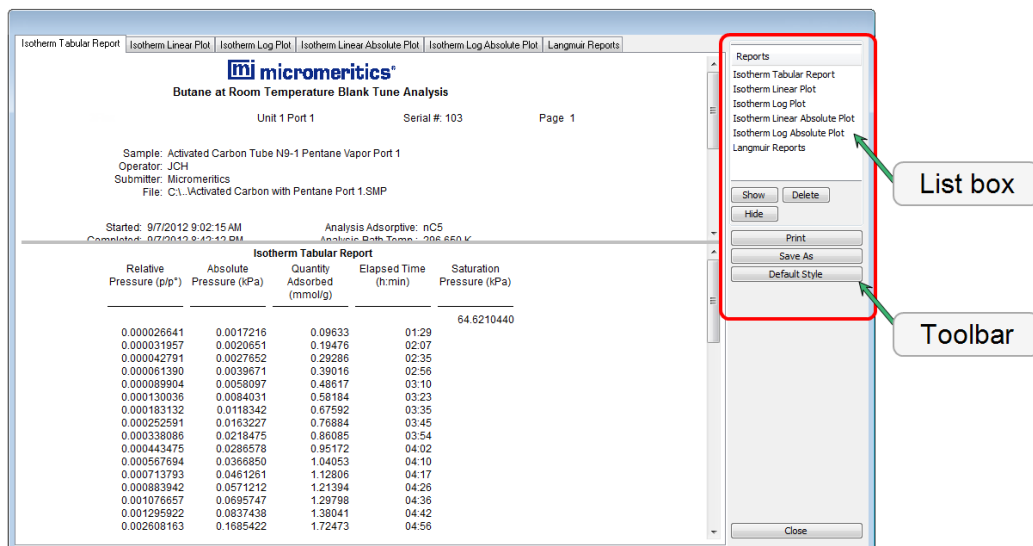

Report Toolbar

Field or Button	Description
Default Style [button]	Specify default report parameters for fonts and curve properties.
Delete [button]	Deletes the selected report in the <i>Reports</i> list box. Deleted reports will have to be regenerated if deleted in error.
Hide [button]	Hides (or temporarily removes) the selected report from the tabbed view. The report name remains in the <i>Reports</i> list box.
Print [button]	Displays the <i>Print</i> window for report output.
Reports [group box]	Contains a list of all generated reports. The same reports display as tabs at the top of the report header unless the report has been hidden using the Hide button.
Show [button]	Displays the selected or hidden report in the <i>Reports</i> list box.
	For fields and buttons not listed in this table, see Common Fields and Buttons on page 2 - 3 .

TABULAR REPORT FEATURES AND SHORTCUTS

Display tabular report shortcuts by right clicking in the body of the tabular report. Column shortcuts require right clicking on the column to be modified.

The screenshot shows the Micromeritics software interface. At the top, there are navigation tabs: Summary, Error, Tabular Report, Cum. Vol. vs Size, Inc. Vol. vs Size, Diff. Vol. vs Size 1, Cum. Area vs Size, Log Diff. Vol. vs Size 1, and Volume Scale. Below the tabs, the software title 'micromeritics' and 'MICROMERITICS INSTRUMENT CORPORATION' are displayed. The report details include: AutoPore, Serial # 379 Port 2/2, Page 1, Sample: Rock Sample, Operator: N. KELLY, Submitter: Research Lab, File: C:\AutoPore\data\examples\ROCK.SMP. Analysis times for LP, HP, and Report are listed. A 'Tabular Report' table is shown with columns: Pressure (psia), Pore Diameter (nm), Incremental Pore Volume (mL/g), and Cumulative Pore Volume (mL/g). A context menu is open over the table, listing options: Resize column, Rename column, Move column, Align column, Show column, Table data font, Table header font, Edit title..., and Copy table as text.

Pressure (psia)	Pore Diameter (nm)	Incremental Pore Volume (mL/g)	Cumulative Pore Volume (mL/g)
1.60	113035.46	0.0000	0.0000
2.10	86323.90	0.0003	0.0003
3.08	59736.92	0.0010	0.0013
4.08	44325.32	0.0009	0.0022
5.58	32383.88	0.0012	0.0035
7.08	25549.88	0.0013	0.0048
8.55	21151.94	0.0015	0.0063
10.54	17163.30	0.0026	0.0088
13.04	13871.48	0.0052	0.0140
14.74	12272.43	0.0030	0.0170
16.02	11290.45	0.0021	0.0191
20.01	9039.95	0.0046	0.0237
20.51	8918.71	0.0005	0.0242
			0.008
			0.000

Tabular Report Shortcuts

Field or Button	Description
Align column	Select to change the column alignment to either left, right, or centered.
Copy table as text	Use to copy the report contents to the clipboard as tab-delimited text. It can then be pasted into another document.
Edit title	Use to edit the report title and/or title font attributes. Click Font to modify font attributes.
Move column	Right click the column to be moved. Select <i>Move column</i> on the shortcut menu and select <i>Left</i> or <i>Right</i> for the move.
Rename column	Right click the column to be renamed. Select <i>Rename column</i> on the shortcut menu and enter the new column name.
Resize column	Right click the column to be resized. Select <i>Resize column</i> on the shortcut menu and enter the new column width in inches.
Show column	Displays a list of all columns. Click a column to add a checkmark to show the column or remove the checkmark to hide the column.
Table data font	Right click in the report data. Select <i>Table data font</i> on the shortcut menu.
Table header font	Right click in the report data. Select <i>Table header font</i> on the shortcut menu.



For fields and buttons not listed in this table, see [Common Fields and Buttons on page 2 - 3](#).

GRAPH FEATURES AND SHORTCUTS

Right click in the graph area to display graph report shortcuts.

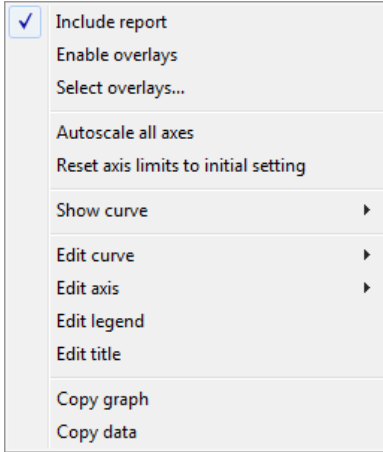

Graph Shortcuts

Field or Button	Description
Autoscale all axes	Returns the report to full view after using the zoom feature.
Copy graph	Copies the graph to the clipboard. It can then be pasted into other software programs.
Edit axis	Use to edit the selected axis properties. <div style="text-align: center; margin: 10px 0;"> </div> <p>Grid lines. Use to change how to display major / minor grid lines.</p> <p>Scale. <i>[group box]</i></p> <ul style="list-style-type: none"> • Autoscale minimum/maximum. <i>[checkbox]</i> To manually specify minimum / maximum autoscale, deselect the option and enter the

Graph Shortcuts (continued)

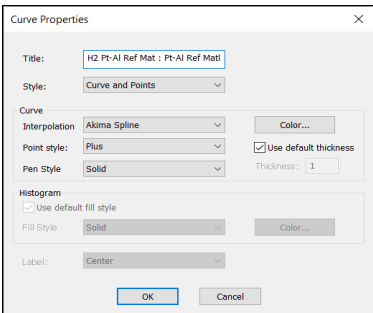
Field or Button	Description
	<p>new amount in the text box.</p> <ul style="list-style-type: none"> • Invert scale. [<i>checkbox</i>] Use to invert the scale. • Linear/Logarithmic. [<i>selection</i>] Select the option to scale the graph as linear or logarithmic. • Scale font. [<i>button</i>] Use to modify the font for the scale label. Deselect <i>Use default font</i> to enable font options. <p>Title. [<i>text box</i>] Use to edit the selected axis label.</p> <p>Title font. [<i>button</i>] Use to modify the font for the selected axis label. Deselect <i>Use default font</i>. Select new font attributes for report data. Enable <i>Use default font</i> to reset default fonts.</p>
Edit curve	<p>Use to edit selected curve properties.</p>  <p>Color. [<i>button</i>] Click to change the curve color.</p> <p>Curve. [<i>group box</i>] Use to change the interpolation, point style, and pen style for the selected curve. These options are disabled if <i>Use default fill style</i> is selected in the <i>Histogram</i> group box.</p> <p>Histogram. [<i>group box</i>] Enabled only if <i>Histogram</i> is selected in the <i>Style</i> drop-down list. Use to specify the type of fill, fill color, and label position for the selected curve.</p> <p>Label. [<i>drop-down box</i>] Select where the graph point labels will display (left, right, center, etc.) on the SPC report.</p>

Graph Shortcuts (continued)

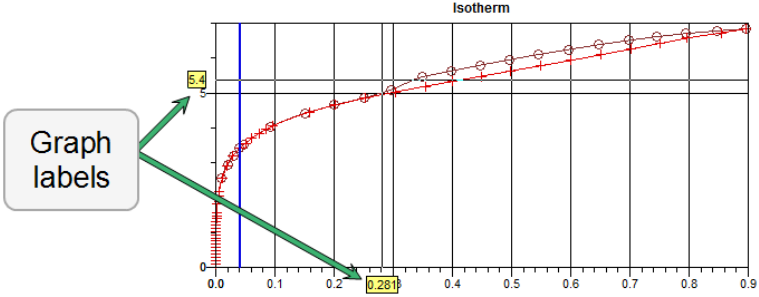
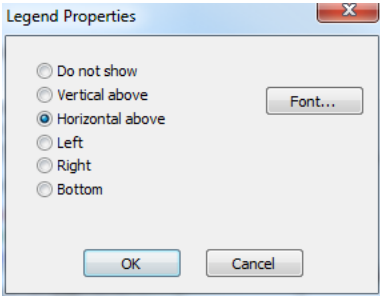
Field or Button	Description
	<div data-bbox="618 310 1372 604" style="text-align: center;">  </div> <p data-bbox="553 657 1382 720">Style. <i>[drop-down box]</i> Use to select another style for the collected data curve.</p> <p data-bbox="553 758 1300 789">Title. <i>[text box]</i> Use to change the title of the selected curve.</p> <p data-bbox="553 827 1425 890">Use default thickness. <i>[check box]</i> Uses the default curve thickness. Deselect to enter a new thickness number in the <i>Thickness</i> text box.</p>
Edit legend	<p data-bbox="553 909 1089 940">Use to change the legend location and font.</p> <div data-bbox="558 968 935 1262" style="text-align: center;">  </div>
Edit title	Select to change the report title.
Enable overlays	If overlays have been selected, this option displays (or hides) the overlays.
Include report	When selected, places a checkmark to the left of the report in the <i>Select Reports</i> list box on the <i>Report Options</i> tab.
Reset axis limits to initial setting	Removes the cross-hair and returns the graph back to the initial setting.

Graph Shortcuts (continued)

Field or Button	Description
Select overlays...	Displays the option to select files to overlay onto the active graph. To view the overlays, click <i>Enable Overlays</i> on the shortcut menu.
Show curve	Displays a list of all curves. Select the curve(s) to display.
 For fields and buttons not listed in this table, see Common Fields and Buttons on page 2 - 3 .	

AXIS CROSS-HAIR

Left click on the graph to view the cross-hair coordinates.

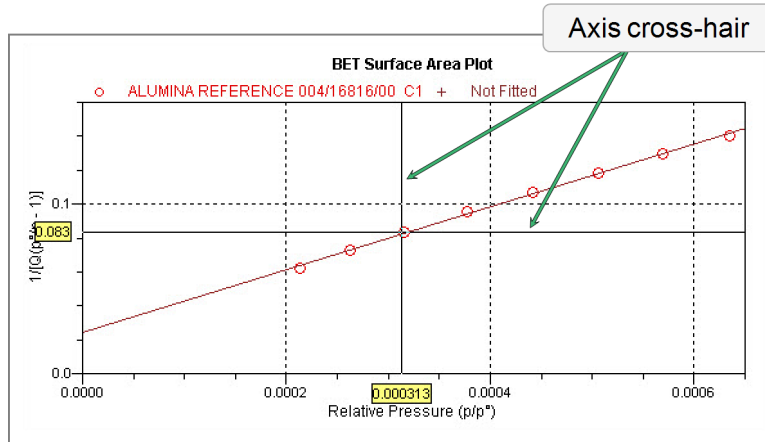

ZOOM FEATURE

Use the zoom feature to examine graph details. Click, hold, and drag the left mouse button on the graphical area to be enlarged. A box will display in the area to be enlarged. To return to normal view, right click in the graph and select *Autoscale all axes*.

GRAPH GRID LINES

Options > Graph Grid Lines

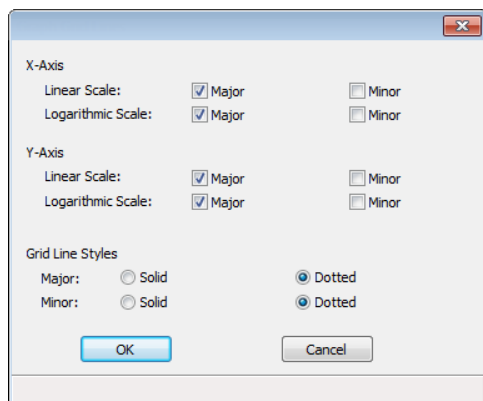

Use to select how grid lines appear on reports. This menu option is not available if using *Restricted* option presentation.

Graph Grid Lines

Field or Button	Description
Grid Line Styles [selection]	Select if the major and/or minor grid lines should appear as solid or dotted lines.
X-Axis / Y-Axis [selection]	Select major and/or minor lines to display in reports for the logarithmic and linear scales. Deselect this option to remove the grid lines.
 For fields and buttons not listed in this table, see Common Fields and Buttons on page 2 - 3 .	

GRAPH AND SAMPLE OVERLAYS

Use the graph overlay functions to compare multiple graph options. Graphical lines are differentiated by the use of varying colored symbols outlined on a legend. Overlays may be generated in two ways:

- **Multiple Graph Overlays.** Overlay two different types of graphs from one sample.
- **Multiple Sample Overlays.** Overlay graphs of the same type with that of the current plot.



This feature is available only when using *Advanced* option presentation. Go to **Options > Option Presentation > Advanced**.

GENERATE PORE SIZE DISTRIBUTION GRAPH OVERLAYS

The following reports in the physical adsorption applications can produce graphical results for a sample material's pore size distribution:



See also:

- [BJH Adsorption/Desorption Report Options on page 8 - 6](#)
- [DFT Pore Size Report Options on page 8 - 12](#)
- [Dollimore-Heal Adsorption/Desorption Report Options on page 8 - 18](#)
- [Horvath-Kawazoe Report Options on page 8 - 33](#)

Two methods can be used to import and overlay report data into another interactive graph using shortcut menu options:

- **Import ASCII text data.** Data can be imported from an ASCII text file into the interactive graph. The ASCII text file must follow certain rules.
- **Copy/paste.** Data can be copied from one sample file (source) and pasted into another sample file (target).

Pore size distribution report overlays menu selections are:

- **Copy data.** Used to copy data sets.
- **Paste data.** Used to paste data sets.
- **Edit Imported Data.** Used to edit data sets.
- **Display Imported Data.** Used to hide or show the imported data.

IMPORT ASCII TEXT DATA

ASCII text file format rules

- The header must consist of one line to include title, two unit specifications, and distribution type:
 - Accepted pore dimension units are: A, nm, um
 - Accepted pore volume units are: cm³/g, cm³/g, ml/g
 - Accepted distribution types are: cumulative, incremental

Two examples of a header format:

```
My Title (A, cm3/g, incremental)
My Title (A, cm3/g, cumulative)
```

- The data must be in two columns and should be separated by a comma or white-space.
- The data lines must be ordered so that pore dimensions are monotonically increasing or decreasing.

Sample ASCII Text File

```
silica alumina bjh (A, cm3/g, cumulative)

456.657          0.0133559
444.847          0.0546427
429.168          0.0869924
425.419          0.119721
419.629          0.132681
360.634          0.156611
340.859          0.197672
326.601          0.233092
```

Window appearance will vary depending on the selected report. This function can be performed on samples files with a *Complete* status or during an analysis.

1. Create the ASCII text file using the proper format as indicated above.
2. In the analyzer application, go to **File > Open**. Select a sample file to overlay graphs on to. Click **Open** (or double-click the file name).
3. Right click in the graph area and select *Edit imported data*.
4. In the *Select Imported Overlays* window, if the ASCII text file does not display, click **Import** to locate the file. Select the ASCII text file in the *Select Imported Overlays* window, then click **OK**. If an error message will display instead, verify that the .TXT file format is in the correct format.
5. To include the overlay data in a printed report, see [Print Pore Size Distribution Overlay Data in Reports on the next page](#).

OVERLAY PORE SIZE DISTRIBUTION DATA USING COPY/PASTE

1. Open a source sample file and a target sample file; both should have a *Complete* status. The report will open to the interactive reports window.
2. In the source sample file, right click on the graph and select *Show Curve*. Deselect any differential curve data to hide them in the graph.
3. Right click in the graph area again and select *Copy Data*.
4. Change to the target sample file, right click the graph, and select *Paste data*. The graph now displays overlaid data from the source sample file.

Typically, one new graph will appear showing both the cumulative and differential curves. To show or hide individual curves, right click the graph and select (or deselect) *Display imported data*.

5. Ensure that all parameter fields are set appropriately, then click **Paste**.
6. To include the overlay data in a printed report, see [Print Pore Size Distribution Overlay Data in Reports below](#).

PRINT PORE SIZE DISTRIBUTION OVERLAY DATA IN REPORTS

1. Open the sample file containing the overlay data and select *Advanced* from the drop-down list at the bottom of the window.
2. Click the *Report Options* tab.
3. In the *Selected Reports* list box, select the cumulative, differential, or incremental intrusion graph to show the imported distribution data, then click **Edit** (or double-click the selected report).
4. In the *Overlay* drop-down box, select *Imported*.
5. Click **OK** to close the window.
6. Click **Preview** on the *Report Options* tab. Click **Print** in the reports toolbar section to display print options.

OVERLAY MULTIPLE SAMPLE FILES

To overlay the same type of graph on multiple samples:

1. Go to **File > Open**.
2. Select a .SMP file, then click **Open**. If the Isotherm plot displays, select *Advanced* from the drop-down list at the bottom of the window to display the tabbed window view.
3. Click the *Report Options* tab.
4. In the *Selected Reports* list box, highlight a report then click **Edit**. Use the following table to complete the process for the selected report.

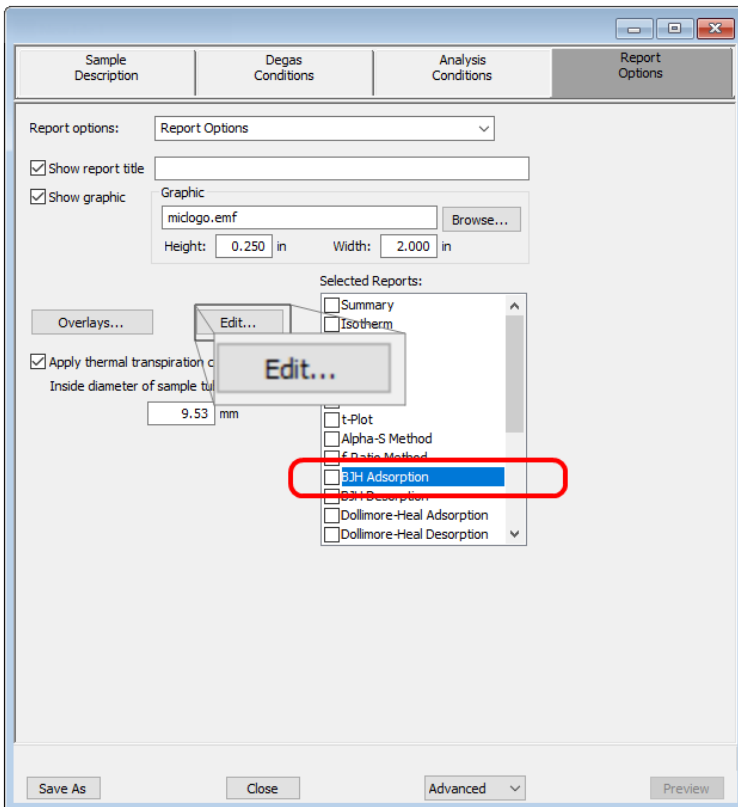

If overlaying this type of report...	Then...
<ul style="list-style-type: none"> • Isotherm 	<ol style="list-style-type: none"> On the <i>Isotherm Report Options</i> window, select one or more plots in the <i>Selected Reports</i> group box, then click Options to the right of the selected plot. On the <i>Plot Options</i> window, select <i>Plot curve</i> and/or <i>Plot points</i> if they are to be included in the overlay. If the x- and/or y-axes are to be autoscaled, enable <i>Autoscale</i>; otherwise, enter the <i>From</i> and <i>To</i> points for the axes. Click OK. On the <i>Isotherm Report Options</i> window, in the <i>Plot Options</i> group box, select <i>Plot overlays</i>. Click OK. Continue to Step 5.
<ul style="list-style-type: none"> • Alpha-S Method • BET Surface Area • <i>f</i>-Ratio Method • Freundlich • Langmuir Surface Area • <i>t</i>-plot • Temkin 	<ol style="list-style-type: none"> On the pop-up window, select <i>Overlay samples</i>. Verify other fields. Click OK. Continue to Step 5.
<ul style="list-style-type: none"> • BJH • Dollimore-Heal • MP-Method 	<ol style="list-style-type: none"> Select the report variable from the <i>Selected Reports</i> group box, then click Edit. Click the down arrow on the <i>Overlay</i> field, then select the <i>Samples</i> option. Verify other fields. Click OK. Click OK again.

5. On the *Report Options* tab, click **Overlays**.

6. On the *Plot Overlay Sample Selection* window, move up to 25 files from the *Available Files* box to the *Selected Files* box:

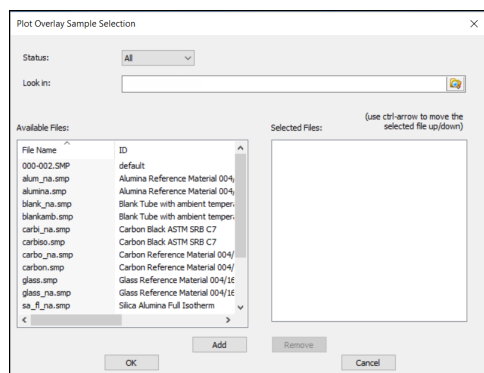

7. Click **OK**.

8. To view the report, click **Preview**.

Plot Overlay Sample Selection

Field	Description
Status <i>[drop-down box]</i>	Select the status of files to be combined.
Look in <i>[button]</i>	Click the Browse icon to change the file folder location.
Available Files <i>[selection]</i>	Lists files that meet the selected criteria. Select the files to be combined, then click Add . The selected files are moved to the <i>Selected Files</i> list box.
Selected Files <i>[selection]</i>	Lists the files selected to be combined. Click OK to combine the files.
	For fields and buttons not listed in this table, see Common Fields and Buttons on page 2 - 3 .

IMPORT ASCII PORE DISTRIBUTION DATA

Import an ASCII Text File using Graph Shortcuts

1. Create an ASCII text file. See [Manually Enter Data on page 3 - 5](#).
2. Open a report with a *Complete* status.
3. Select a pore-size distribution report from the drop-down list at the bottom of the window.
4. Right click on the graph and select *Edit imported data* on the shortcut menu.

If the ASCII text file does not display on the *Selected Imported Overlays* window, click **Import**. Locate and select the file, then click **Open**. Header information from the ASCII text file will appear in the *Select Imported Overlays* window. Select the entry, then click **OK**. If an error message appears, verify that the .TXT file format is correct.

5. To hide or show imported data, right click in the graph area and use the *Display imported data* option on the shortcut menu.

Copy/Paste an ASCII Text File using Graph Shortcuts

1. Create an ASCII text file. See [Manually Enter Data on page 3 - 5](#).
2. Copy the ASCII text data to the clipboard.
3. Open a report with a *Complete* status.
4. Select a pore-size distribution report from the drop-down list at the bottom of the window.
5. Right click on the graph and select *Paste data* on the shortcut menu.
6. To hide or show imported data, right click in the graph area and use the *Display imported data* option on the shortcut menu.

Copy/Paste Graph Data from Another Graph

1. Open a source pore distribution data report with a *Complete* status.
2. Right click on the graph and select *Copy Data* on the shortcut menu.
3. Open the target pore distribution data report.
4. Right click on the graph and select *Paste Data* on the shortcut menu.
5. To hide or show imported data, right click in the graph area and use the *Display imported data* option on the shortcut menu.

REPORT EXAMPLES

HORVATH-KAWAZOE DIFFERENTIAL PORE VOLUME PLOT

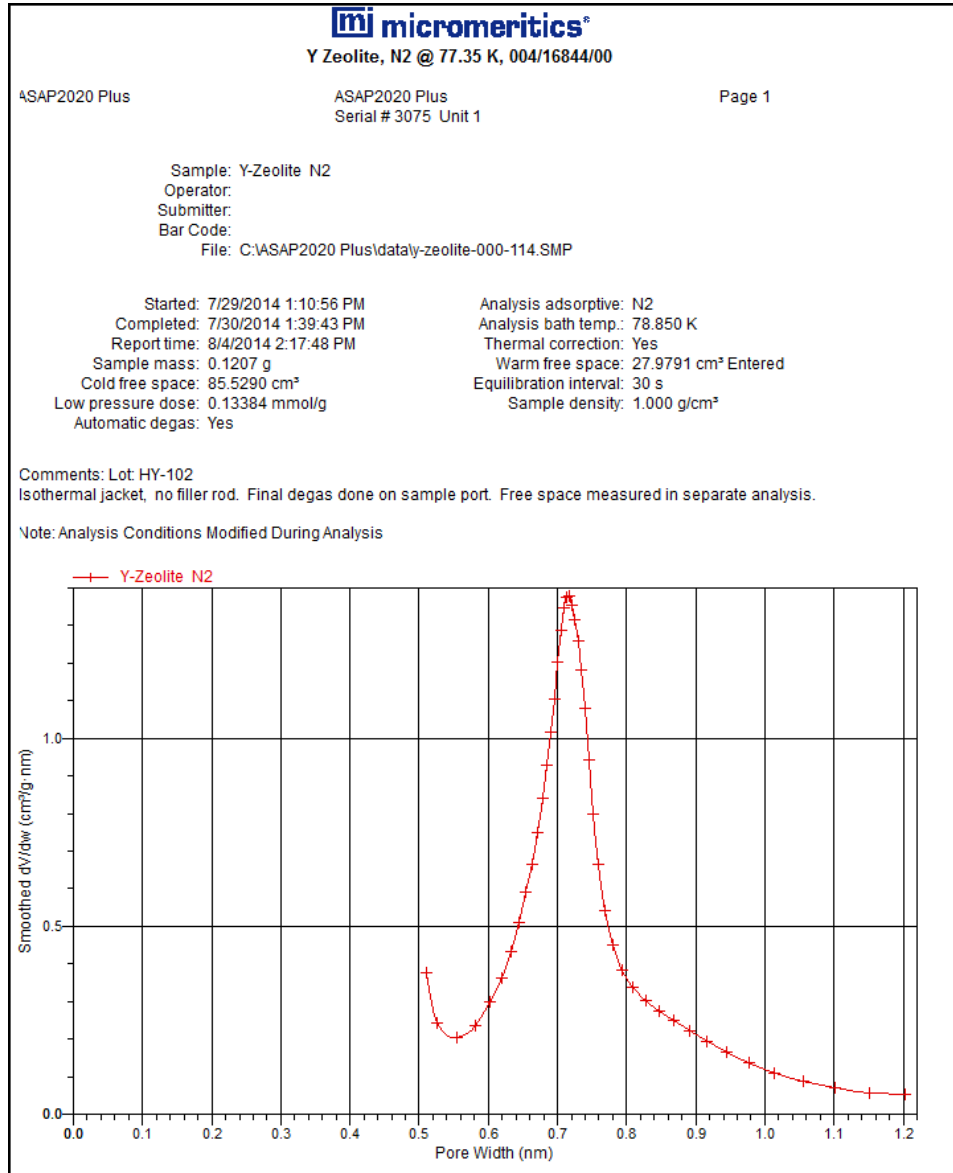

ISOTHERM LOG REPORT

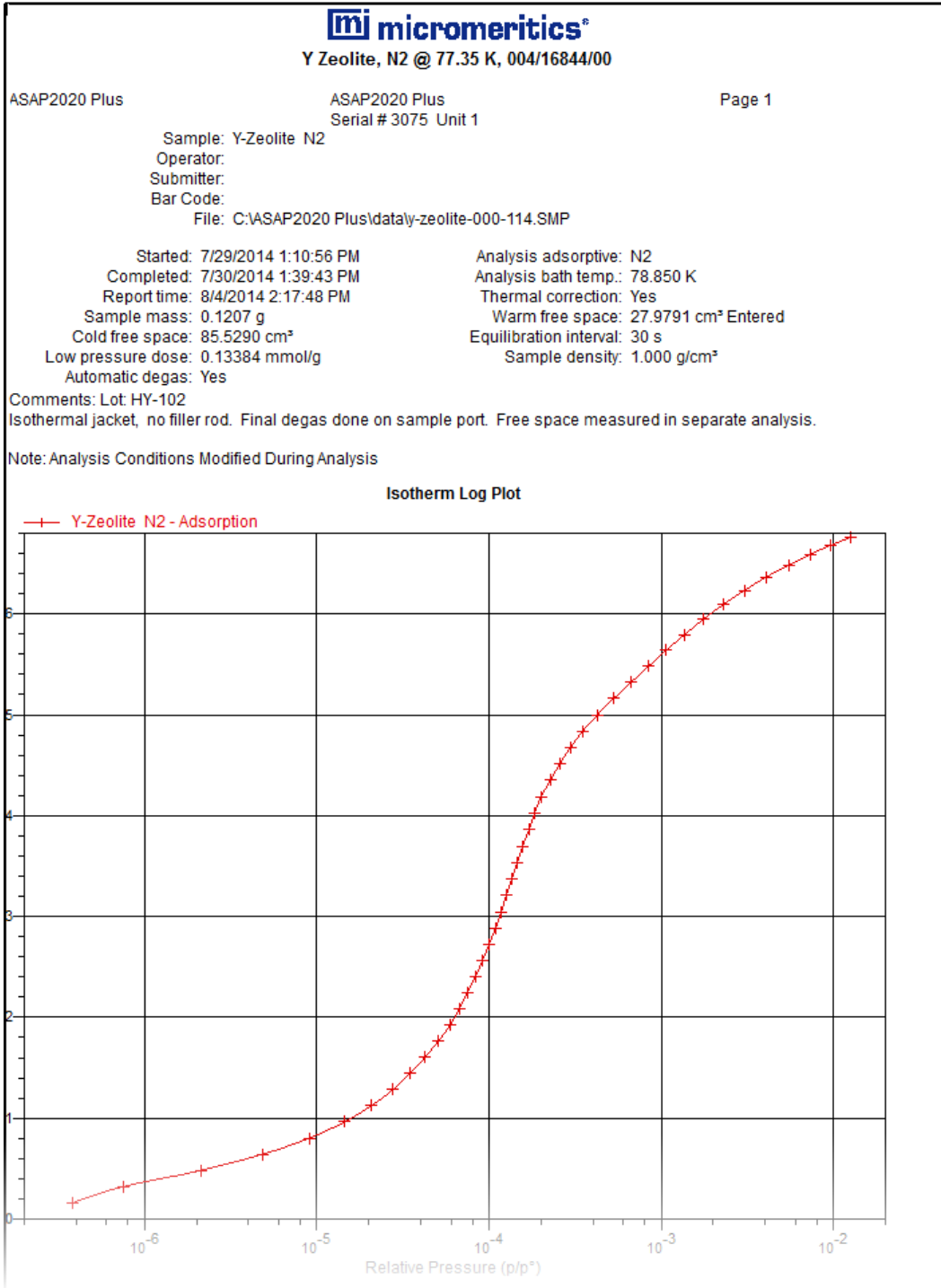

ISOTHERM TABULAR REPORT

Y Zeolite, N2 @ 77.35 K, 004/16844/00					
ASAP2020 Plus	ASAP2020 Plus	Page 1			
	Serial # 3075 Unit 1				
Sample: Y-Zeolite N2 Operator: Submitter: Bar Code: File: C:\ASAP2020 Plus\data\y-zeolite-000-114.SMP					
Started: 7/29/2014 1:10:56 PM		Analysis adsorptive: N2			
Completed: 7/30/2014 1:39:43 PM		Analysis bath temp.: 78.850 K			
Report time: 8/4/2014 2:17:48 PM		Thermal correction: Yes			
Sample mass: 0.1207 g		Warm free space: 27.9791 cm ³ Entered			
Cold free space: 85.5290 cm ³		Equilibration interval: 30 s			
Low pressure dose: 0.13384 mmol/g		Sample density: 1.000 g/cm ³			
Automatic degas: Yes					
Comments: Lot: HY-102					
Isothermal jacket, no filler rod. Final degas done on sample port. Free space measured in separate analysis.					
Note: Analysis Conditions Modified During Analysis					
Isotherm Tabular Report					
Relative Pressure (p/p [*])	Absolute Pressure (kPa)	Quantity Adsorbed (mmol/g)	Elapsed Time (h:min)	Time Between Points (min)	Saturation Pressure (kPa)
0.000000379	0.0000374	0.16089	01:33	0093	98.6415445
0.000000748	0.0000737	0.32188	02:29	0056	98.5841762
0.000002107	0.0002076	0.48270	03:24	0055	98.5437579
0.000004872	0.0004800	0.64328	04:16	0052	98.5329515
0.000009019	0.0008884	0.80340	05:05	0049	98.5096136
0.000014358	0.0014145	0.96301	05:55	0050	98.5161479
0.000020608	0.0020305	1.12242	06:44	0049	98.5262870
0.000027523	0.0027124	1.28173	07:31	0047	98.5478999
0.000034883	0.0034383	1.44122	08:15	0044	98.5664367
0.000042604	0.0042003	1.60092	08:53	0038	98.5895143
0.000050740	0.0050027	1.76120	09:28	0035	98.5963171
0.000058894	0.0058071	1.92139	10:04	0036	98.6039255
0.000067104	0.0066175	2.08141	10:40	0036	98.6143251
0.000075401	0.0074352	2.24125	11:15	0035	98.6093938
0.000083640	0.0082472	2.40112	11:52	0037	98.6028595
0.000091982	0.0090674	2.56077	12:29	0037	98.5779104
0.000100342	0.0098896	2.72038	13:05	0036	98.5584377
0.000108362	0.0106771	2.88335	13:42	0037	98.5322924
0.000116805	0.0115079	3.04630	14:18	0036	98.5217464
0.000125579	0.0123729	3.20924	14:55	0037	98.5261487
0.000134742	0.0132750	3.37219	15:31	0036	98.5218847
0.000146134	0.0143988	3.53512	16:07	0036	98.5312183
0.000157082	0.0154792	3.69806	16:42	0035	98.5421630
0.000169574	0.0167131	3.86101	17:17	0035	98.5592352
0.000184211	0.0181585	4.02398	17:50	0033	98.5743056
0.000202514	0.0199685	4.18692	18:22	0032	98.6032583

OPTIONS REPORT

																														
Y Zeolite, N2 @ 77.35 K, 004/16844/00																														
ASAP2020 Plus	ASAP2020 Plus Serial # 3075 Unit 1	Page 1																												
Sample: Y-Zeolite N2 Operator: Submitter: Bar Code: File: C:\ASAP2020 Plus\data\y-zeolite-000-114.SMP																														
<table border="0" style="width: 100%;"> <tr> <td style="width: 50%;">Started: 7/29/2014 1:10:56 PM</td> <td style="width: 50%;">Analysis adsorptive: N2</td> </tr> <tr> <td>Completed: 7/30/2014 1:39:43 PM</td> <td>Analysis bath temp.: 78.850 K</td> </tr> <tr> <td>Report time: 8/5/2014 7:35:34 AM</td> <td>Thermal correction: Yes</td> </tr> <tr> <td>Sample mass: 0.1207 g</td> <td>Warm free space: 27.9791 cm³ Entered</td> </tr> <tr> <td>Cold free space: 85.5290 cm³</td> <td>Equilibration interval: 30 s</td> </tr> <tr> <td>Low pressure dose: 0.13384 mmol/g</td> <td>Sample density: 1.000 g/cm³</td> </tr> <tr> <td>Automatic degas: Yes</td> <td></td> </tr> </table>			Started: 7/29/2014 1:10:56 PM	Analysis adsorptive: N2	Completed: 7/30/2014 1:39:43 PM	Analysis bath temp.: 78.850 K	Report time: 8/5/2014 7:35:34 AM	Thermal correction: Yes	Sample mass: 0.1207 g	Warm free space: 27.9791 cm ³ Entered	Cold free space: 85.5290 cm ³	Equilibration interval: 30 s	Low pressure dose: 0.13384 mmol/g	Sample density: 1.000 g/cm ³	Automatic degas: Yes															
Started: 7/29/2014 1:10:56 PM	Analysis adsorptive: N2																													
Completed: 7/30/2014 1:39:43 PM	Analysis bath temp.: 78.850 K																													
Report time: 8/5/2014 7:35:34 AM	Thermal correction: Yes																													
Sample mass: 0.1207 g	Warm free space: 27.9791 cm ³ Entered																													
Cold free space: 85.5290 cm ³	Equilibration interval: 30 s																													
Low pressure dose: 0.13384 mmol/g	Sample density: 1.000 g/cm ³																													
Automatic degas: Yes																														
Comments: Lot: HY-102 Isothermal jacket, no filler rod. Final degas done on sample port. Free space measured in separate analysis.																														
Note: Analysis Conditions Modified During Analysis																														
Sample Information																														
<table border="0" style="width: 100%;"> <tr><td style="width: 50%;">Sample: Y-Zeolite N2</td><td style="width: 50%;"></td></tr> <tr><td>Operator:</td><td></td></tr> <tr><td>Submitter:</td><td></td></tr> <tr><td>Bar Code:</td><td></td></tr> <tr><td>Mass type: Calculated</td><td></td></tr> <tr><td>Empty tube: 36.9063 g</td><td></td></tr> <tr><td>Sample + tube: 37.0270 g</td><td></td></tr> <tr><td>Sample mass: 0.1207 g</td><td></td></tr> <tr><td>Density: 1.000 g/cm³</td><td></td></tr> <tr><td>Type of data: Automatically collected</td><td></td></tr> <tr><td>Instrument type: 2020</td><td></td></tr> <tr><td>Original instrument type: 2020</td><td></td></tr> <tr><td>Comments: Lot: HY-102</td><td></td></tr> <tr><td style="padding-left: 20px;">Isothermal jacket, no filler rod. Final degas done on sample port. Free space measured in separate analysis.</td><td></td></tr> </table>			Sample: Y-Zeolite N2		Operator:		Submitter:		Bar Code:		Mass type: Calculated		Empty tube: 36.9063 g		Sample + tube: 37.0270 g		Sample mass: 0.1207 g		Density: 1.000 g/cm ³		Type of data: Automatically collected		Instrument type: 2020		Original instrument type: 2020		Comments: Lot: HY-102		Isothermal jacket, no filler rod. Final degas done on sample port. Free space measured in separate analysis.	
Sample: Y-Zeolite N2																														
Operator:																														
Submitter:																														
Bar Code:																														
Mass type: Calculated																														
Empty tube: 36.9063 g																														
Sample + tube: 37.0270 g																														
Sample mass: 0.1207 g																														
Density: 1.000 g/cm ³																														
Type of data: Automatically collected																														
Instrument type: 2020																														
Original instrument type: 2020																														
Comments: Lot: HY-102																														
Isothermal jacket, no filler rod. Final degas done on sample port. Free space measured in separate analysis.																														
Sample Tube																														
<table border="0" style="width: 100%;"> <tr><td style="width: 50%;">Sample tube: Sample Tube</td><td style="width: 50%;"></td></tr> <tr><td>Warm free space: 1.0000 cm³</td><td></td></tr> <tr><td>Cold free space: 1.0000 cm³</td><td></td></tr> <tr><td>Non-ideality factor: 0.0000620</td><td></td></tr> <tr><td>Use isothermal jacket: Yes</td><td></td></tr> <tr><td>Use filler rod: No</td><td></td></tr> <tr><td>Vacuum seal type: Seal Frit</td><td></td></tr> </table>			Sample tube: Sample Tube		Warm free space: 1.0000 cm ³		Cold free space: 1.0000 cm ³		Non-ideality factor: 0.0000620		Use isothermal jacket: Yes		Use filler rod: No		Vacuum seal type: Seal Frit															
Sample tube: Sample Tube																														
Warm free space: 1.0000 cm ³																														
Cold free space: 1.0000 cm ³																														
Non-ideality factor: 0.0000620																														
Use isothermal jacket: Yes																														
Use filler rod: No																														
Vacuum seal type: Seal Frit																														
Degas Conditions																														
Degas conditions: Y Zeolite Degas Conditions, 004/16844/00																														

8 SELECTED REPORTS



To edit reports, open the *Sample* file then select the *Report Options* tab. Highlight the report name in the *Selected Reports* list box and click **Edit**.

Log in to your [customer portal](#) to access MicroActive Report Tutorials.

ADVANCED REPORT OPTIONS



See:

[Advanced Reports - Python Module on page I - 1](#)

ALPHA-S METHOD REPORT OPTIONS

The *Alpha-S* plot converts the standard adsorption isotherm into a dimensionless isotherm using the quantity adsorbed at a relative pressure of 0.4.

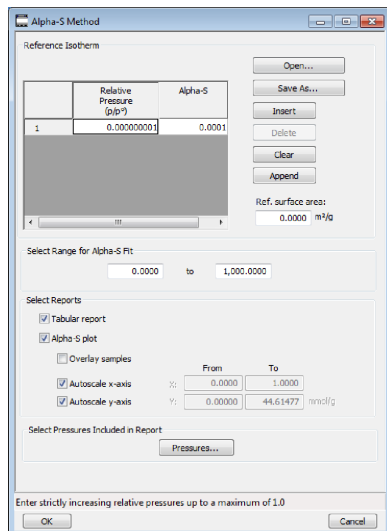

One predefined curve is located in the *Reference* file directory. Use the table buttons to enter relative pressure and the alpha-s values.

Alpha-S Method Reports

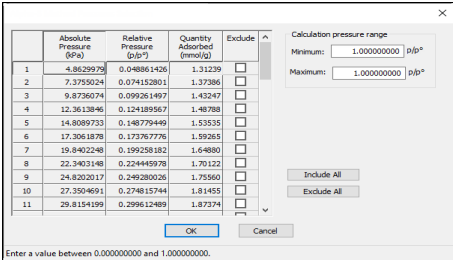
Field or Button	Description
Open [button]	Use to import values from an existing thickness curve (.ALS). The table to be imported must be saved as ASCII text with a .ALS file extension. It must have a two-column format with the relative pressures in the first column and the alpha-s values in the second column. Columns must be separated by a space or a tab.
Pressures [button]	Use to select a pressure range for report calculations and points for exclusion from calculations. <div data-bbox="558 1398 1008 1656" style="border: 1px solid black; padding: 5px; margin-top: 10px;">  <p>Enter a value between 0.000000000 and 1.000000000.</p> </div> <p>Calculation pressure range. Enter the minimum and maximum pressures to be used in the pressure table. To exclude a point from the</p>

Alpha-S Method Reports (continued)

Field or Button	Description
	calculations used to generate the report, select <i>Exclude</i> . Exclude All. Select to exclude all pressure points in the table. Include All. Select to include all pressure points in the table.
Ref. surface area <i>[text box]</i>	Enter the surface area from the reference curve. This value is used to calculate the sample surface area.
Select Range for Alpha-S Fit <i>[group box]</i>	Enter minimum and maximum relative pressures to determine the fit.
Selected Reports <i>[group box]</i>	Alpha-S Plot. Use to plot data in graph format. <ul style="list-style-type: none"> • Autoscale x-axis. The x-axis field shows the relative pressure. • Autoscale y-axis. The y-axis field shows the quantity of gas adsorbed. • Overlay samples. Use to overlay sample files on the plot. Tabular Report. Use to have a tabular report of data generated.
 For fields and buttons not listed in this table, see Common Fields and Buttons on page 2 - 3 .	

BET SURFACE AREA REPORT OPTIONS

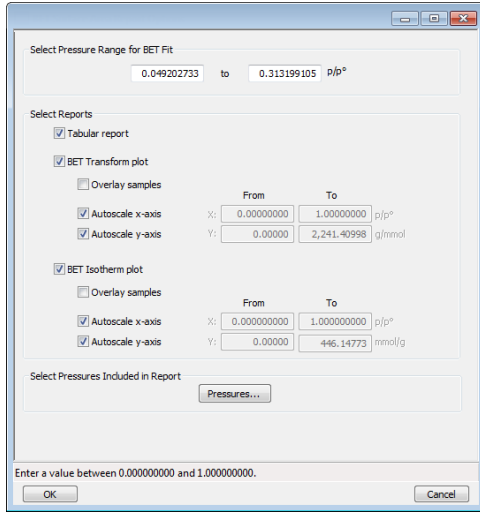

The BET calculation obtains the sample surface area value by determining the monolayer volume of adsorbed gas from the isotherm data. BET uses a multilayer model.

BET Reports

Field or Button	Description
Pressures [button]	<p>This option is available when the sample file has a status of <i>Analyzing</i> or <i>Complete</i>. Use to enter a range of pressure points to be included in the report or to modify table values for pressure points.</p> <p>Calculation pressure range. Enter the minimum and maximum pressures to be used in the pressure table if not using the <i>Use Interpolation</i> option.</p> <p>Exclude All. Select to exclude all pressure points in the table.</p>

BET Reports (continued)

Field or Button	Description
	<p>Include All. Select to include all pressure points in the table.</p> <p>Insert Predefined. Click to insert a predefined (default) set of points into the report. <i>Use Interpolation</i> must be selected to enable this button. This button displays for BET reports only.</p> <p>Use Interpolation. Use to indicate if the system should use the table or interpolated data. This option is available for BET and Langmuir reports only.</p>
Select Pressure Range for BET fit <i>[text box]</i>	Enter values to indicate the fitted pressure range.
Selected Reports <i>[group box]</i>	<p>BET Isotherm plot. Uses BET monolayer volume and constant to produce an isotherm.</p> <ul style="list-style-type: none"> • Autoscale x-axis. Linear x-axes begin at zero. The x-axis field shows the relative pressure for BET. • Autoscale y-axis. The y-axis field shows the quantity of gas adsorbed. • Overlay samples. Use to overlay sample files on the BET isotherm plot. <p>BET Transform plot. Use to generate a traditional BET surface area plot used to determine monolayer volume and BET C constant.</p> <ul style="list-style-type: none"> • Autoscale x-axis. Linear x-axes begin at zero. The x-axis field shows the relative pressure for BET. • Autoscale y-axis. The y-axis field shows BET transformation. • Overlay samples. Use to overlay sample files on the BET transform plot. <p>Tabular report. Use to have a table of measured and calculated values generated.</p>
	For fields and buttons not listed in this table, see Common Fields and Buttons on page 2 - 3 .

BJH ADSORPTION/DESORPTION REPORT OPTIONS

The BJH calculation determines the mesopore volume/area distribution, which accounts for both the change in adsorbate layer thickness and the liquid condensed in pore cores. Reports can be generated from both adsorption and desorption data. The fields for both *BJH Adsorption Report Options* and *BJH Desorption Report Options* are identical unless otherwise specified.



An incomplete pore distribution may be generated if a thickness curve selection is not a good match for the sample being analyzed.

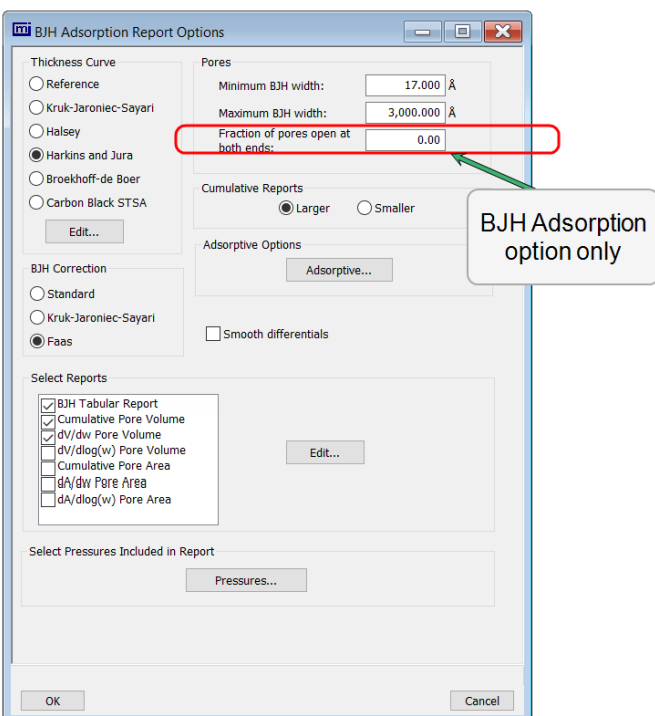

BJH Adsorption/Desorption Reports

Field or Button	Description
Adsorptive [button]	Displays the <i>Adsorptive Options</i> window. The recommended adsorptives and their values are shown. Up to eight adsorptive and adsorbate property factor combinations may be specified.



BJH Adsorption/Desorption Reports (continued)

Field or Button	Description
BJH Correction <i>[group box]</i>	<p>Select the type of correction to apply to calculations. The selected type will display in the report header.</p> <p>Faas. Good for statistical thickness curves.</p> <p>Kruk-Jaroniec-Sayari. Good for reference thickness curves.</p> <p>Standard. Uses original BJH models.</p>
Cumulative Reports <i>[group box]</i>	<p>Larger. Use to report the total volume found in pores larger than the current pore size.</p> <p>Smaller. Use to report the total volume found in pores smaller than the current pore size.</p>
Pores <i>[group box]</i>	<p>Enter the minimum and maximum diameter (radius or width) of pores to include in the BJH reports.</p> <p>Fraction of pores open at both ends. This field is not available for the <i>BJH Desorption Report Options</i> window.</p> <p>During adsorption calculations, the analysis program assumes that all pores are closed at one end. Occasionally, a percentage of pores may be open at both ends causing disagreement in the adsorption and desorption data or in the values for total volume and total BJH pore volume. Enter the fraction of pores open at both ends to compensate for this error.</p>

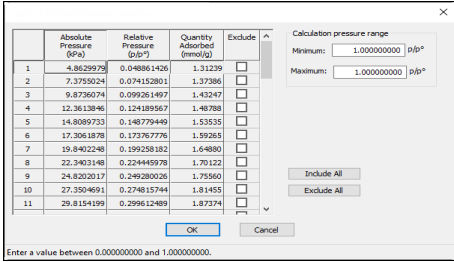
BJH Adsorption/Desorption Reports (continued)

Field or Button	Description
Pressures [button]	<p>Use to select a pressure range for report calculations and points for exclusion from calculations.</p>  <p>Calculation pressure range. Enter the minimum and maximum pressures to be used in the pressure table. To exclude a point from the calculations used to generate the report, select <i>Exclude</i>.</p> <p>Exclude All. Select to exclude all pressure points in the table.</p> <p>Include All. Select to include all pressure points in the table.</p>
Select Reports [group box]	Select the report names to include in the report. Highlight the report name, then click Edit to modify report parameters.
Smooth differentials [check box]	Use to smooth all differential calculations, thus eliminating variations in the differential computation caused by noise in the input data.
Thickness Curve [group box]	<p>Select the thickness curve, then click Edit to modify the values in the equation for the selected curve. The Frenkel-Halsey-Hill thickness curve can be applied using the Halsey option.</p> <p>Kruk-Jaroniec-Sayari / Halsey / Harkins and Jura / Broekhoff-de Boer / Carbon Black STSA. Select the thickness curve option, then click Edit. Modify the equation for the selected curve as needed.</p> <p>Reference. Select <i>Reference</i>, then click Edit to define a t-curve by entering both the relative pressure and thickness values. One predefined curve is shipped with the analysis program and is found in the <i>Reference</i> directory.</p>

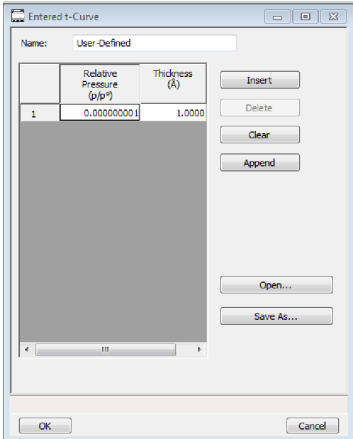
BJH Adsorption/Desorption Reports (continued)

Field or Button	Description
	 <p>To import values from an existing thickness curve (.THK file), click Open, then select the file containing the values. The table to be imported must have a .TXT or .THK file extension and have a two-column format with the relative pressures in the first column and the thickness values in the second column. Columns must be separated by a space or a tab.</p>
	<p>For fields and buttons not listed in this table, see Common Fields and Buttons on page 2 - 3.</p>

BJH PLOT OPTIONS

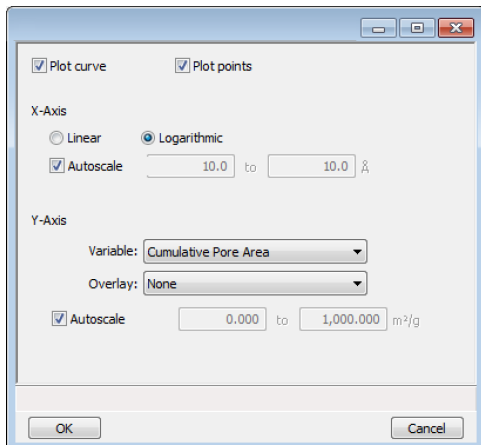

The fields for all plot options are identical for specifying plotting methods and customizing plots. Highlight any plot option in the *Selected Reports* list box in the *BJH Report Options* window, then click [Edit](#).

BJH Plot Reports

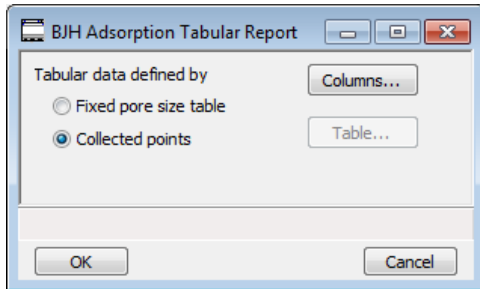

Field or Button	Description
Autoscale [check box]	When enabled on the report parameters windows, allows the x- and y- axes to be scaled automatically. <i>Autoscale</i> means that the x- and y- ranges will be set so that all the data is shown. If <i>Autoscale</i> is not selected, the entered range is used.
Plot curve / Plot points [check box]	Select to plot points on the graph.
X-Axis [group box]	Use to have the x-axis on a logarithmic or linear scale.
Y-Axis [group box]	Overlay. Select an option to overlay onto the current report. Variable. Select a variable.
	For fields and buttons not listed in this table, see Common Fields and Buttons on page 2 - 3 .

BJH TABULAR REPORT OPTIONS

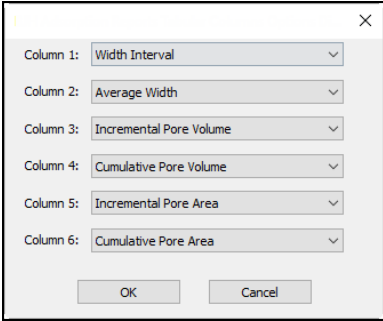

Highlight *BJH Tabular Report* in the *Selected Reports* list box on the *BJH Adsorption Report Options* window, then click **Edit** to specify the method of data reduction.

BJH Tabular Reports

Field or Button	Description
Collected points <i>[selection]</i>	Use to include all relative pressure points collected. Refer to the Columns button below.
Columns <i>[button]</i>	Select the data types to include in the report. <i>Column [n]</i> indicates the column order and data contents for the report. 
Fixed pore size table <i>[selection]</i>	Use to specify exact pore sizes for volume or area data. Click Table to modify the fixed pore size table. Refer to Table and Columns buttons elsewhere in this table.
Table <i>[button]</i>	The fixed pore size table must contain a minimum of two points. The points must be strictly decreasing. Enabled only when <i>Fixed pore size table</i> is selected.
 For fields and buttons not listed in this table, see Common Fields and Buttons on page 2 - 3.	

DFT PORE SIZE REPORT OPTIONS

The *DFT Pore Size* report contains the results of pore size distribution analyses using a non-local DFT range of micro and mesopore ranges.

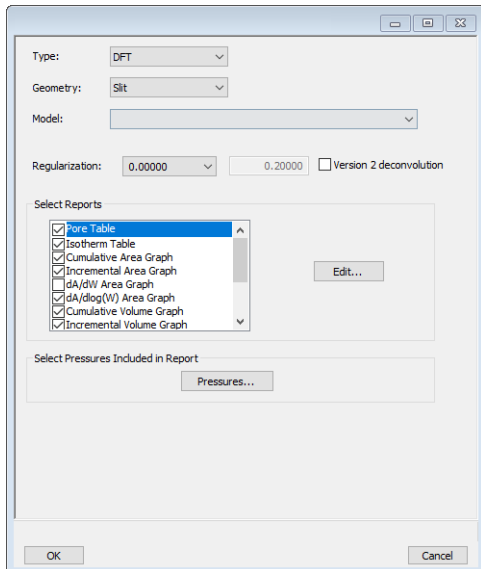

DFT Pore Size Reports

Field or Button	Description																																																												
Geometry [drop-down box]	Select the pore shape.																																																												
Model [drop-down box]	Lists the models that meet the specified criteria and match the adsorbate and temperature of the sample data. If no models appear, no models meet the selected criteria. One model must be selected.																																																												
Pressures [button]	Use to select a pressure range for report calculations and points for exclusion from calculations. <div data-bbox="557 1352 1008 1612" style="border: 1px solid black; padding: 5px; margin-top: 10px;"> <table border="1"> <thead> <tr> <th></th> <th>Absolute Pressure (Pa)</th> <th>Relative Pressure (p/p⁰)</th> <th>Quantity Adsorbed (mmol/g)</th> <th>Exclude</th> </tr> </thead> <tbody> <tr><td>1</td><td>4.86259726</td><td>0.048861426</td><td>1.31239</td><td><input type="checkbox"/></td></tr> <tr><td>2</td><td>7.3755024</td><td>0.074152801</td><td>1.37386</td><td><input type="checkbox"/></td></tr> <tr><td>3</td><td>9.8726074</td><td>0.099261497</td><td>1.43247</td><td><input type="checkbox"/></td></tr> <tr><td>4</td><td>12.3612846</td><td>0.124189507</td><td>1.48788</td><td><input type="checkbox"/></td></tr> <tr><td>5</td><td>14.8089733</td><td>0.148779449</td><td>1.53535</td><td><input type="checkbox"/></td></tr> <tr><td>6</td><td>17.3061878</td><td>0.172767776</td><td>1.59265</td><td><input type="checkbox"/></td></tr> <tr><td>7</td><td>19.8402248</td><td>0.199258182</td><td>1.64880</td><td><input type="checkbox"/></td></tr> <tr><td>8</td><td>22.3403148</td><td>0.224445978</td><td>1.70122</td><td><input type="checkbox"/></td></tr> <tr><td>9</td><td>24.8202017</td><td>0.249280026</td><td>1.75560</td><td><input type="checkbox"/></td></tr> <tr><td>10</td><td>27.3504691</td><td>0.274815744</td><td>1.81455</td><td><input type="checkbox"/></td></tr> <tr><td>11</td><td>29.8154199</td><td>0.299612488</td><td>1.87374</td><td><input type="checkbox"/></td></tr> </tbody> </table> <p>Calculation pressure range Minimum: 1.000000000 p/p⁰ Maximum: 1.000000000 p/p⁰</p> <p>Include All Exclude All</p> <p>OK Cancel</p> <p>Enter a value between 0.000000000 and 1.000000000.</p> </div>		Absolute Pressure (Pa)	Relative Pressure (p/p ⁰)	Quantity Adsorbed (mmol/g)	Exclude	1	4.86259726	0.048861426	1.31239	<input type="checkbox"/>	2	7.3755024	0.074152801	1.37386	<input type="checkbox"/>	3	9.8726074	0.099261497	1.43247	<input type="checkbox"/>	4	12.3612846	0.124189507	1.48788	<input type="checkbox"/>	5	14.8089733	0.148779449	1.53535	<input type="checkbox"/>	6	17.3061878	0.172767776	1.59265	<input type="checkbox"/>	7	19.8402248	0.199258182	1.64880	<input type="checkbox"/>	8	22.3403148	0.224445978	1.70122	<input type="checkbox"/>	9	24.8202017	0.249280026	1.75560	<input type="checkbox"/>	10	27.3504691	0.274815744	1.81455	<input type="checkbox"/>	11	29.8154199	0.299612488	1.87374	<input type="checkbox"/>
	Absolute Pressure (Pa)	Relative Pressure (p/p ⁰)	Quantity Adsorbed (mmol/g)	Exclude																																																									
1	4.86259726	0.048861426	1.31239	<input type="checkbox"/>																																																									
2	7.3755024	0.074152801	1.37386	<input type="checkbox"/>																																																									
3	9.8726074	0.099261497	1.43247	<input type="checkbox"/>																																																									
4	12.3612846	0.124189507	1.48788	<input type="checkbox"/>																																																									
5	14.8089733	0.148779449	1.53535	<input type="checkbox"/>																																																									
6	17.3061878	0.172767776	1.59265	<input type="checkbox"/>																																																									
7	19.8402248	0.199258182	1.64880	<input type="checkbox"/>																																																									
8	22.3403148	0.224445978	1.70122	<input type="checkbox"/>																																																									
9	24.8202017	0.249280026	1.75560	<input type="checkbox"/>																																																									
10	27.3504691	0.274815744	1.81455	<input type="checkbox"/>																																																									
11	29.8154199	0.299612488	1.87374	<input type="checkbox"/>																																																									
	Calculation pressure range. Enter the minimum and maximum pressures to be used in the pressure table. To exclude a point from the calculations used to generate the report, select <i>Exclude</i> .																																																												

DFT Pore Size Reports (continued)

Field or Button	Description
	<p>Exclude All. Select to exclude all pressure points in the table.</p> <p>Include All. Select to include all pressure points in the table.</p>
Regularization <i>[drop-down box]</i>	Select the extent of smoothing to apply to the data. If <i>0.20000 (user)</i> is selected, enter a number in the text box giving a relative weight for the smoothing during deconvolution. Larger values produce more smoothing.
Select Reports <i>[group box]</i>	<p>Select the reports to generate. To edit graph details, highlight the graph option and click Edit. The <i>Log Goodness of Fit</i> and <i>Goodness of Fit</i> graphs cannot be edited.</p> <div style="text-align: center;"> </div> <p>Autoscale Options. Use to autoscale the x-axis and/or y-axes.</p> <p>Axis Range. <i>From/To</i> fields are enabled when <i>Autoscale</i> options are not selected. Enter the starting and ending values for the x- and/or y-axes.</p> <ul style="list-style-type: none"> • x-axis. Shows the pore size. • y-axis. Shows the area. <p>Overlay. Select an overlay for the report.</p> <p>Plot Type. Select the method for data display.</p>

DFT Pore Size Reports (continued)

Field or Button	Description
Type <i>[drop-down box]</i>	<p>Classical. Model based on the Kelvin equation and thickness for determining the pore size distribution. See DFT Models on page F - 1.</p> <p>DFT. Model based on the density functional theory.</p>
<p>For fields and buttons not listed in this table, see Common Fields and Buttons on page 2 - 3.</p>	

DFT SURFACE ENERGY REPORT OPTIONS

See also:

[DFT Pore Size Report Options on page 8 - 12](#)

The *DFT Surface Energy* report contains the results of surface energy distribution analyses.

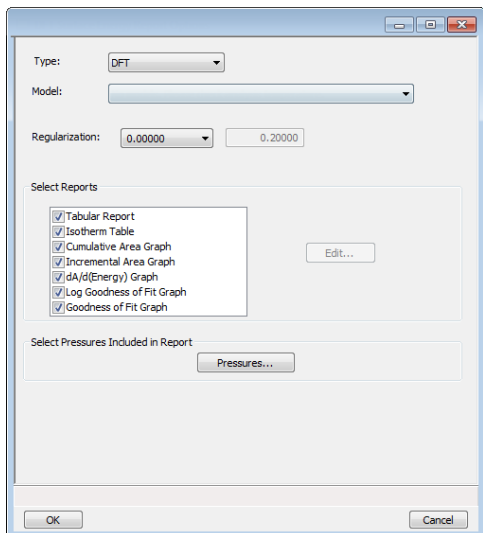

DFT Surface Energy Report Options fields and buttons are identical to the *DFT Pore Size Report Options*.

DIFFERENCE METHOD REPORT OPTIONS FOR CHEMICAL ADSORPTION

The *Difference Method Report* and the *Sinfelt Method Report* windows are identical unless otherwise specified.

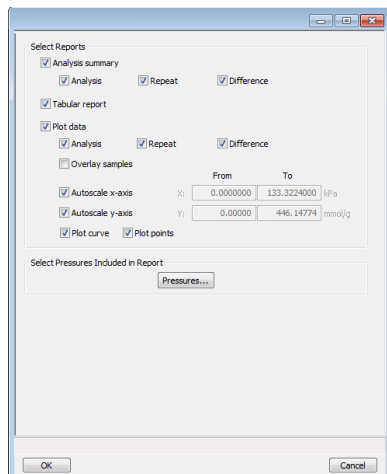

The y-intercept quantity adsorbed (Q_0) is used for several calculations in the *Difference* and *Sinfelt* reports. This value can be determined in two ways. If one point is selected, Q_0 is the quantity adsorbed for that point.

Difference Method. The repeat isotherm data are subtracted from the primary isotherm. Q_0 is the y-intercept of a straight line through the difference data.

Sinfelt Method. Both the primary and repeat isotherms are fitted to a straight line. Q_0 is the difference between the y-intercepts of the fit lines.

Difference and Sinfelt Reports

Field or Button	Description
Analysis summary [selection]	<p>Analysis. Generates a summary of the following for the first analysis:</p> <ul style="list-style-type: none"> • Percent metal dispersion • Metallic surface area • Volume adsorbed • Slope • Correlation coefficient <p>Difference. Generates a summary of the differences between the following information for the first and repeat analyses:</p> <ul style="list-style-type: none"> • Percent metal dispersion • Metallic surface area

Difference and Sinfelt Reports (continued)

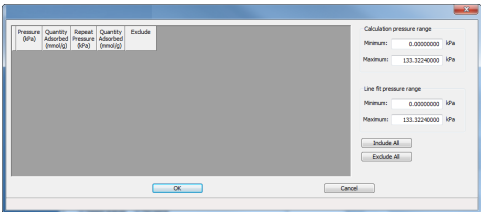
Field or Button	Description
	<ul style="list-style-type: none"> Average difference volume <p>Repeat. (Sinfelt report only). Generates a line fit plot for the secondary analysis.</p>
Plot data [selection]	<p>Analysis. Includes a line fit plot for the primary analysis.</p> <p>Autoscale x-axis / Autoscale y-axis. Select to have the x- and/or y- axes automatically scaled. The application uses the highest values collected during analysis as the ending points for an axis range. X-axis shows the pressure. Y-axis shows the quantity of gas adsorbed.</p> <p>Difference. Plots the difference between the analysis and repeat analysis lines.</p> <p>Overlay samples. Overlays data from the current sample with that of other samples. Click Overlays on the <i>Report Options</i> window to choose other sample files.</p> <p>Plot curve and Plot points. Use to specify how to plot data. Plot data as a curve, points, or both.</p> <p>Repeat. Includes a line fit plot for the secondary analysis.</p>
Pressures [button]	<p>Use to enter a range of pressure points to be included in the report or to modify table values for pressure points.</p>  <p>Calculation pressure range. Enter the minimum and maximum pressures to be used in the pressure table.</p> <p>Exclude All. Select to exclude all pressure points in the table.</p> <p>Include All. Select to include all pressure points in the table.</p> <p>Line fit pressure range. Enter the minimum and maximum pressures for line fit.</p>

Difference and Sinfelt Reports (continued)

Field or Button	Description
Tabular report [<i>selection</i>]	Select to have a report of the pressure points generated.
 For fields and buttons not listed in this table, see Common Fields and Buttons on page 2 - 3 .	

DOLLIMORE-HEAL ADSORPTION/DESORPTION REPORT OPTIONS



See also:

[BJH Adsorption/Desorption Report Options on page 8 - 6](#) for additional information on field and buttons for this report.

The *Dollimore-Heal Adsorption Report Option* and the *Dollimore-Heal Desorption Report Option* generate reports from both adsorption and desorption data.

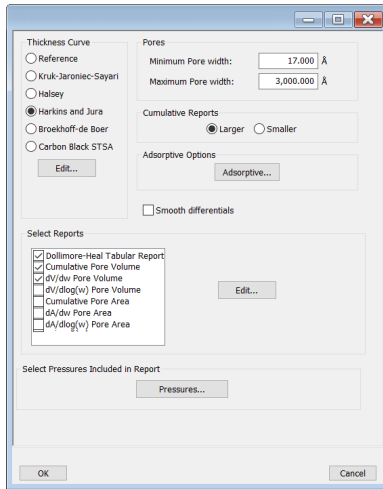

Dollimore-Heal Adsorption/Desorption Reports

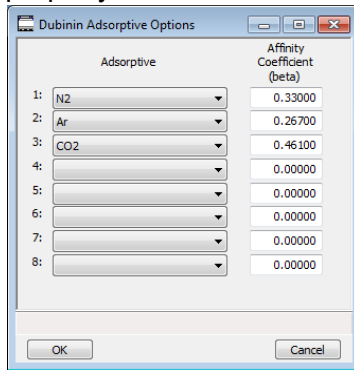

Field or Button	Description
Adsorptive [button]	Displays the <i>Adsorptive Options</i> window. The recommended adsorptives and their values are shown. Up to eight adsorptive and adsorbate property factor combinations may be specified.

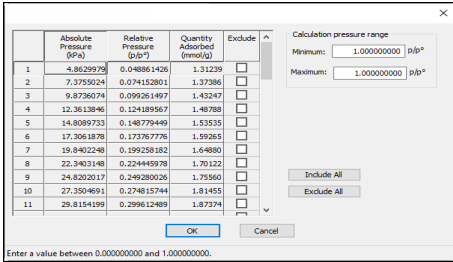

Dollimore-Heal Adsorption/Desorption Reports (continued)

Field or Button	Description
Cumulative Reports <i>[group box]</i>	<p>Larger. Use to report the total volume found in pores larger than the current pore size.</p> <p>Smaller. Use to report the total volume found in pores smaller than the current pore size.</p>
Pores <i>[group box]</i>	Enter the minimum and maximum diameter (radius or width) of pores to include in the BJH reports.
Pressures <i>[button]</i>	<p>Use to select a pressure range for report calculations and points for exclusion from calculations.</p>  <p>Calculation pressure range. Enter the minimum and maximum pressures to be used in the pressure table. To exclude a point from the calculations used to generate the report, select <i>Exclude</i>.</p> <p>Exclude All. Select to exclude all pressure points in the table.</p> <p>Include All. Select to include all pressure points in the table.</p>
Select Reports <i>[group box]</i>	Select the report names to include in the report. Highlight the report name, then click Edit to modify report parameters.
Smooth differentials <i>[check box]</i>	Use to smooth all differential calculations, thus eliminating variations in the differential computation caused by noise in the input data.
Thickness Curve <i>[group box]</i>	<p>Select the thickness curve, then click Edit to modify the values in the equation for the selected curve. The Frenkel-Halsey-Hill thickness curve can be applied using the Halsey option.</p> <p>Kruk-Jaroniec-Sayari / Halsey / Harkins and Jura / Broekhoff-de Boer / Carbon Black STSA. Select the thickness curve option, then click Edit. Modify the equation for the selected curve as needed.</p> <p>Reference. Select <i>Reference</i>, then click Edit to define a t-curve by entering both the relative pressure and thickness values. One predefined curve is shipped with the analysis program and is found in the <i>Reference</i> directory.</p>

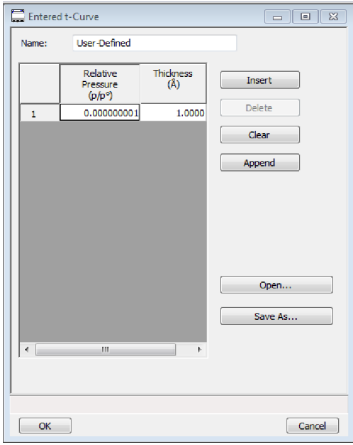
Dollimore-Heal Adsorption/Desorption Reports (continued)

Field or Button	Description
	 <p>To import values from an existing thickness curve (.THK file), click Open, then select the file containing the values. The table to be imported must have a .TXT or .THK file extension and have a two-column format with the relative pressures in the first column and the thickness values in the second column. Columns must be separated by a space or a tab.</p>
	<p>For fields and buttons not listed in this table, see Common Fields and Buttons on page 2 - 3.</p>

DOLLIMORE-HEAL PLOT OPTIONS



See also:

[BJH Plot Options on page 8 - 10](#)

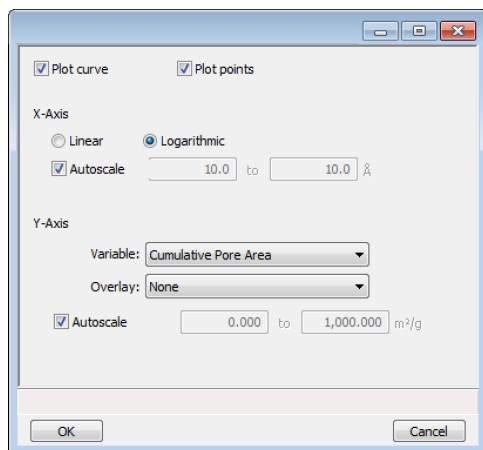

The fields for all plot options are identical for specifying plotting methods and customizing plots. Highlight any plot option in the *Selected Reports* list box in the *Dollimore-Heal Report Options* window, then click **Edit**. The fields and buttons for these reports are identical to the *BJH Plot Report Options*.

DOLLIMORE-HEAL TABULAR REPORT OPTIONS



See also:

[*BJH Tabular Report Options on page 8 - 11*](#)

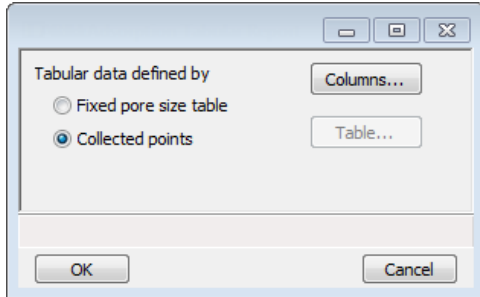

Dollimore-Heal Tabular Report Options are identical to the *BJH Tabular Report Options*.

DUBININ REPORT OPTIONS

The *Dubinin* method provides pore volume distributions for microporous materials by making use of an expression for the adsorption potential.

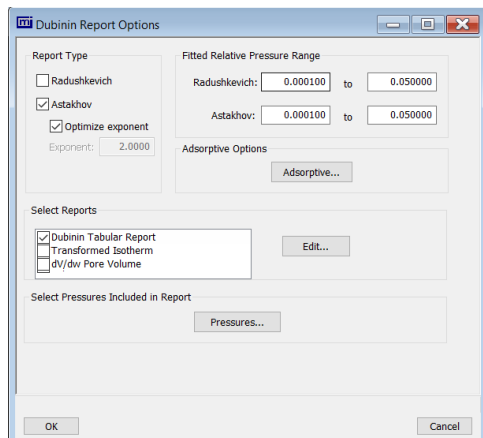

Dubinin Reports

Field or Button	Description
Adsorptive [<i>button</i>]	Displays the <i>Adsorptive Options</i> window. The recommended adsorptives and their values are shown. Up to eight adsorptive and adsorbate property factor combinations may be specified. <div style="text-align: center;"> </div>
Fitted Relative Pressure Range [<i>group box</i>]	Enter the minimum and maximum limits for Radushkevich or Astakhov relative pressures included in the line fit.

Dubin Reports (continued)

Field or Button	Description
Pressures [button]	<p>Use to select a pressure range for report calculations and points for exclusion from calculations.</p> <p>Calculation pressure range. Enter the minimum and maximum pressures to be used in the pressure table. To exclude a point from the calculations used to generate the report, select <i>Exclude</i>.</p> <p>Exclude All. Select to exclude all pressure points in the table.</p> <p>Include All. Select to include all pressure points in the table.</p>
Report Type [group box]	Select report types. If <i>Astakhov</i> is selected, either select <i>Optimize exponent</i> or enter an appropriate exponent value in the text box.
Select Reports [group box]	Select the reports to generate. Highlight the report, then click Edit to modify report options.
<p>For fields and buttons not listed in this table, see Common Fields and Buttons on page 2 - 3.</p>	

DUBININ PORE VOLUME REPORT OPTIONS

In the *Dubinin Report Options* window, highlight *dV/dw Pore Volume* in the *Selected Reports* list box, then click [Edit](#).

This option plots differential pore volume as a function of pore width.

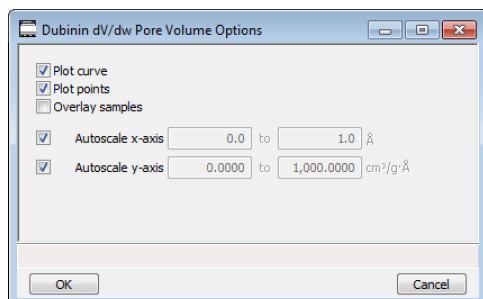

Dubinin Pore Volume Reports

Field or Button	Description
Autoscale x-axis / Autoscale y-axis [check box]	Select an option to have the x- and/or y-axes scaled automatically. Both axes begin at 0; the system uses the highest values collected during analysis as the ending points for axis ranges. Enable to enter beginning and ending values manually.
Overlay samples [selection]	Use to overlay sample files on the plot.
Plot curve / Plot points [selection]	Select to plot points on the graph.
 For fields and buttons not listed in this table, see Common Fields and Buttons on page 2 - 3 .	

DUBININ TABULAR REPORT OPTIONS

In the *Dubinin Report Options* window, highlight *Dubinin Tabular Report* in the *Selected Reports* list box, then click **Edit**. *Column [n]* indicates the column order and data contents for the report.

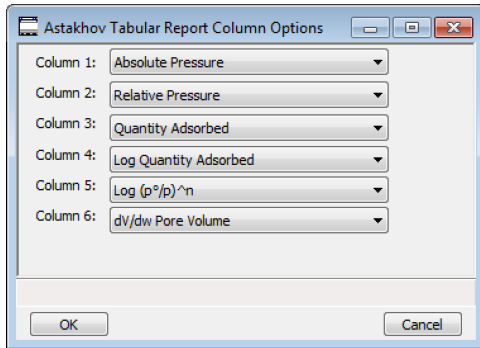

Log (p°/p)^n. The value for *[n]* is the optimized exponent if *Optimize exponent* is selected on the *Dubinin Report Options* window. If not, then the value for *[n]* is the entered exponent value.

DUBININ TRANSFORMED ISOTHERM PLOT OPTIONS

Highlight *Transformed Isotherm* in the *Selected Reports* list box in the *Dubinin Report Options* window, then click **Edit**.

The transformed Dubinin isotherm is the logarithm of quantity adsorbed as a function of the log of relative pressure raised to a power. Isotherms for which the Dubinin method is applicable produce straight lines when transformed in this way.

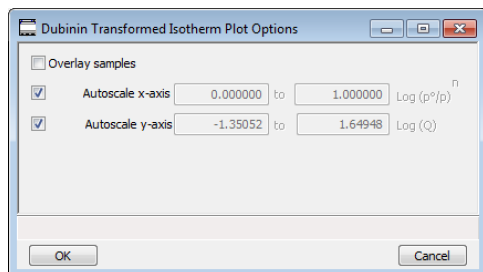

Dubinin Transformed Isotherm Plot Reports

Field or Button	Description
Autoscale x-axis / Autoscale y-axis [checkbox]	<p>Select an option to have the x- and/or y-axes scaled automatically. Both axes begin at 0; the system uses the highest values collected during analysis as the ending points for axis ranges.</p> <p>Deselect to enter beginning and ending values manually.</p> <p>Autoscale x-axis. Shows the quantity of gas adsorbed at standard temperature and pressure.</p> <p>Autoscale y-axis. Shows the log of relative pressure.</p>
Overlay Samples [checkbox]	Use to overlay sample files on the plot.
 <p>For fields and buttons not listed in this table, see Common Fields and Buttons on page 2 - 3.</p>	

F-RATIO METHOD REPORT OPTIONS

The *f*-Ratio report uses the measured isotherm and normalizes it using a reference isotherm.

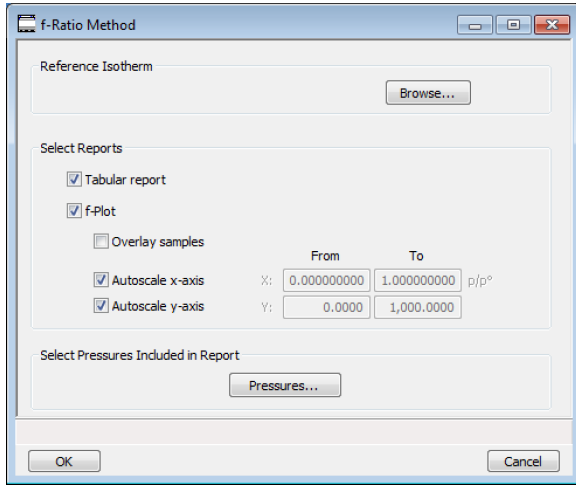

f-Ratio Reports

Field or Button	Description
Pressures [button]	<p>Use to select a pressure range for report calculations and points for exclusion from calculations.</p> <p>Calculation pressure range. Enter the minimum and maximum pressures to be used in the pressure table. To exclude a point from the calculations used to generate the report, select <i>Exclude</i>.</p> <p>Exclude All. Select to exclude all pressure points in the table.</p> <p>Include All. Select to include all pressure points in the table.</p>

f-Ratio Reports (continued)

Field or Button	Description
Reference isotherm <i>[group box]</i>	Browse to select a sample file to use as a reference for the isotherm. Select a file containing an isotherm measured from a non-porous sample of the same material as the current sample.
Selected Reports <i>[group box]</i>	<p>Tabular Report. Use to have a tabular report of data generated.</p> <p>f-Plot. Use to generate a normalized isotherm.</p> <ul style="list-style-type: none"> • Autoscale x-axis. The x-axis field is dimensionless in units of f-ratio. • Autoscale y-axis. The y-axis field shows the quantity of gas adsorbed. • Overlay samples. Use to overlay sample files on the f-plot.
	<p>For fields and buttons not listed in this table, see Common Fields and Buttons on page 2 - 3.</p>

FREUNDLICH REPORT OPTIONS

The *Freundlich Isotherm* is an empirical isotherm used to model low-pressure adsorption data. It can also be applied to model some micropore isotherms. In the *Selected Reports* list box, highlight *Freundlich*, then click **Edit**.

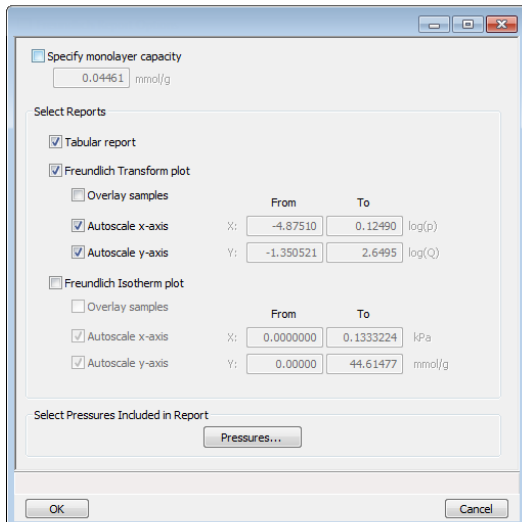

Specify monolayer capacity: 0.04461 mmol/g

Select Reports:

- Tabular report
- Freundlich Transform plot
 - Overlay samples
 - Autoscope x-axis: X: -4.87510 To: 0.12490 log(p)
 - Autoscope y-axis: Y: -1.350521 To: 2.6495 log(Q)
- Freundlich Isotherm plot
 - Overlay samples
 - Autoscope x-axis: X: 0.0000000 To: 0.1333224 kPa
 - Autoscope y-axis: Y: 0.00000 To: 44.61477 mmol/g

Select Pressures Included in Report: Pressures...

Physical Adsorption

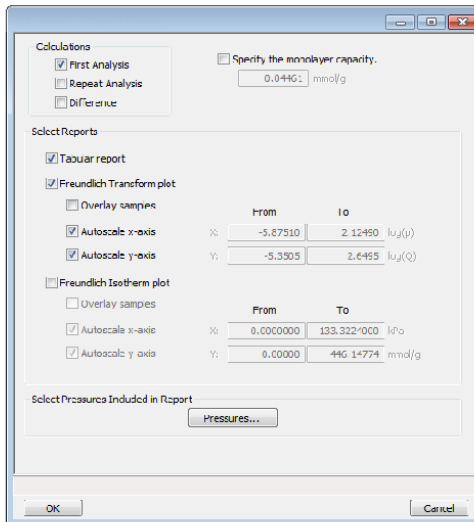

Calculations:

- First Analysis
- Repeat Analysis
- Difference

Specify the monolayer capacity: 0.04461 mmol/g

Select Reports:

- Tabular report
- Freundlich Transform plot
 - Overlay samples
 - Autoscope x-axis: X: -5.87510 To: 2.12490 log(p)
 - Autoscope y-axis: Y: -5.3505 To: 2.6495 log(Q)
- Freundlich Isotherm plot
 - Overlay samples
 - Autoscope x-axis: X: 0.0000000 To: 133.322*000 kPa
 - Autoscope y-axis: Y: 0.00000 To: 44.614774 mmol/g

Select Pressures Included in Report: Pressures...

Chemical Adsorption

Freundlich Reports

Field or Button	Description
Calculations [group box] 	Select from the various calculation options. Difference. Plots the difference between the analysis and repeat analysis lines. First Analysis. Includes a line fit plot for the primary analysis. Repeat Analysis. Includes a line fit plot for the secondary analysis.

Freundlich Reports (continued)

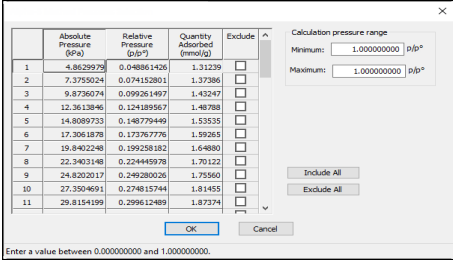
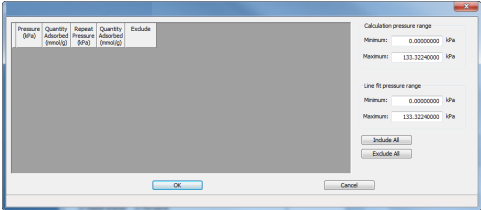
Field or Button	Description
Pressures [button] P	<p>Use to select a pressure range for report calculations and points for exclusion from calculations.</p>  <p>Calculation pressure range. Enter the minimum and maximum pressures to be used in the pressure table. To exclude a point from the calculations used to generate the report, select <i>Exclude</i>.</p> <p>Exclude All. Select to exclude all pressure points in the table.</p> <p>Include All. Select to include all pressure points in the table.</p>
Pressures [button] C	<p>Use to enter a range of pressure points to be included in the report or to modify table values for pressure points.</p>  <p>Calculation pressure range. Enter the minimum and maximum pressures to be used in the pressure table.</p> <p>Exclude All. Select to exclude all pressure points in the table.</p> <p>Include All. Select to include all pressure points in the table.</p> <p>Line fit pressure range. Enter the minimum and maximum pressures for line fit.</p>

Freundlich Reports (continued)

Field or Button	Description
Select Reports <i>[group box]</i>	<p>Freundlich Isotherm plot. Plots the absolute pressure vs quantity adsorbed. Shows best fit line.</p> <ul style="list-style-type: none"> • Autoscale x-axis. Linear x-axes begin at zero. The x-axis field shows the absolute pressure. • Autoscale y-axis. y-axes begin at zero. The y-axis field shows the quantity of gas adsorbed. • Overlay samples. Use to overlay sample files on the Freundlich isotherm plot. <p>Freundlich Transform plot. Plots the $\log(P)$ vs $\log(Q)$ and the best fit.</p> <ul style="list-style-type: none"> • Autoscale x-axis. The x-axis field shows the absolute pressure. • Autoscale y-axis. The y-axis field shows the quantity of gas adsorbed. • Overlay samples. Use to overlay sample files on the Freundlich transform plot. <p>Tabular report. Select to include pressure points included in the report.</p>
Specify monolayer capacity <i>[selection]</i>	Select and enter the monolayer capacity of the sample.
Tabular report <i>[selection]</i>	Use to have a report of the pressure points generated.
<div style="border: 1px solid green; padding: 5px;">  <p>For fields and buttons not listed in this table, see Common Fields and Buttons on page 2 - 3.</p> </div>	

HORVATH-KAWAZOE REPORT OPTIONS

The *Horvath-Kawazoe* method plots individual peaks for different pore sizes even if the difference between one pore size and the next is only one angstrom (0.10 nm) or less.

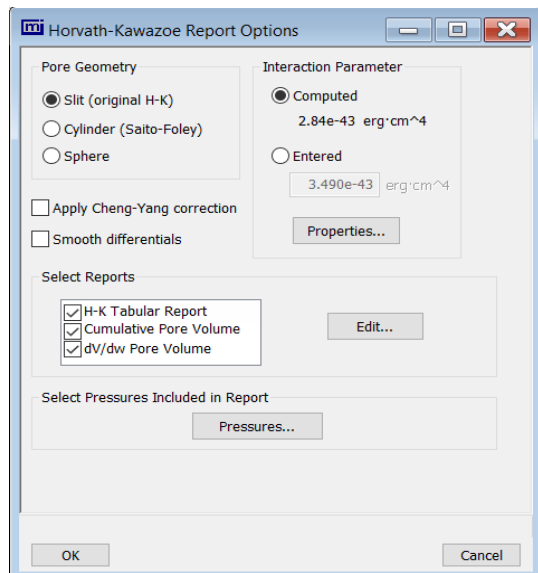

Horvath-Kawazoe Reports

Field or Button	Description
Apply Cheng-Yang correction <i>[selection]</i>	Use to apply the Cheng-Yang correction to the pore size analysis. This correction substitutes the Langmuir equation of state for Henry's Law in the Horvath-Kawazoe derivation.
Interaction Parameter <i>[group box]</i>	Use to determine which interaction parameter will be used in the report. These options are disabled if <i>Sphere</i> is selected in the <i>Pore Geometry</i> group box. Computed. Use to calculate using the parameters on the <i>Horvath-Kawazoe Physical Properties</i> window (click Properties to display the <i>Physical Properties</i> window). The interaction parameter is recalculated each time a parameter in the <i>Physical Properties</i> window is edited. Entered. Calculates using the value entered in the text box.
Pore Geometry <i>[group box]</i>	Select the option that best represents the physical geometry of the micropores in the sample material. When <i>Sphere</i> is selected, options in the <i>Interaction Parameter</i> group box are disabled.

Horvath-Kawazoe Reports (continued)

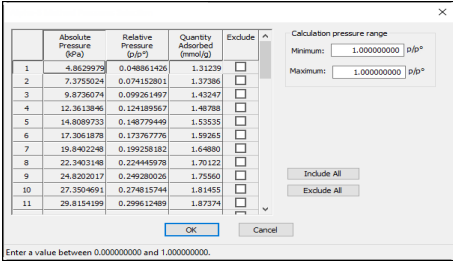
Field or Button	Description
Pressures [button]	<p>Use to select a pressure range for report calculations and points for exclusion from calculations.</p>  <p>Calculation pressure range. Enter the minimum and maximum pressures to be used in the pressure table. To exclude a point from the calculations used to generate the report, select <i>Exclude</i>.</p> <p>Exclude All. Select to exclude all pressure points in the table.</p> <p>Include All. Select to include all pressure points in the table.</p>
Properties [button]	<p>Click to view or edit the constants describing the physical properties of the adsorbent and adsorptive.</p> <p>Adsorbent. Contains the parameters for the sample. If using <i>Computed</i> for the interaction parameter, all fields are enabled. If using <i>Entered</i>, only the values in the <i>Diameter</i> and <i>Diameter at zero energy</i> text fields may be edited.</p> <ul style="list-style-type: none"> • Density. Enter the density per unit area of the sample. * • Description. Select the name of the sample used in the analysis. • Diameter. Enter the diameter of the sample atom. • Diameter at zero energy. Enter the diameter of an atom at zero interaction energy: $(2/5)^{1/6} \times \text{diameter}$. • Magnetic susceptibility. Enter the magnetic susceptibility of the sample. * • Polarizability. Enter the polarizability of the sample. * <p>Adsorptive. Contains the parameters for the adsorptives. If using <i>Computed</i> for the interaction parameter, all fields are enabled. If using <i>Entered</i>, only the values in the <i>Diameter</i> and <i>Diameter at zero energy</i> text fields may be edited.</p> <ul style="list-style-type: none"> • Density. Enter the density per unit area of the adsorptive. * • Diameter. Enter the diameter of the gas phase atom.

Horvath-Kawazoe Reports (continued)

Field or Button	Description
	<ul style="list-style-type: none"> • Diameter at zero energy. Enter the diameter of an atom at zero interaction energy: $(2/5)^{1/6} \times \text{diameter}$. • Magnetic susceptibility. Enter the magnetic susceptibility of the adsorptive. * • Mnemonic. Select the mnemonic of the adsorptive gas in use. • Polarizability. Enter the polarizability of the adsorptive. * <p>* Option is disabled if <i>Entered</i> is selected in the <i>Interactions Parameter</i> group box.</p>
Select Reports <i>[group box]</i>	Select the types of reports to generate. Highlight the report, then click Edit to modify report parameters.
Smooth Differentials <i>[selection]</i>	Use to smooth all differential calculations, thus eliminating variations in the differential computation caused by noise in the input data.
	For fields and buttons not listed in this table, see Common Fields and Buttons on page 2 - 3 .

HORVATH-KAWAZOE PLOT OPTIONS



See also:

[BJH Plot Options on page 8 - 10](#) for additional information on fields and buttons for this report.

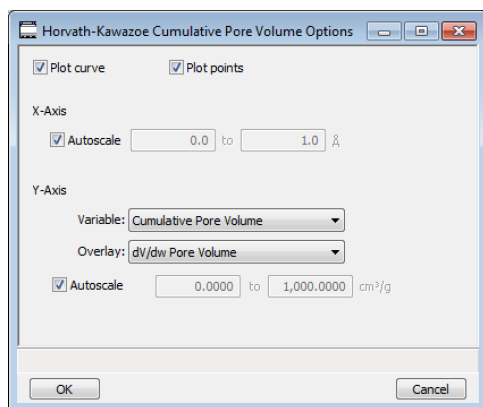

Highlight a plot option in the *Selected Reports* list box in the *Horvath-Kawazoe Report Options* window, then click **Edit** to customize the plotting method.

HORVATH-KAWAZOE TABULAR REPORT OPTIONS

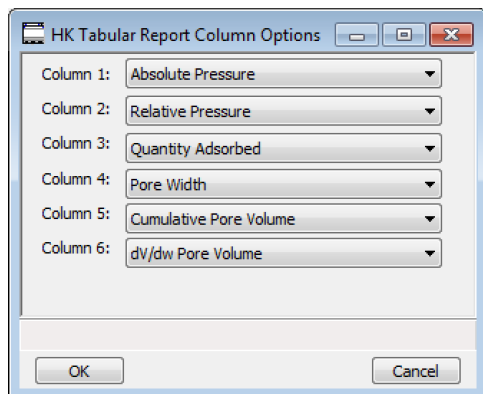

Highlight *H-K Tabular Report* in the *Selected Reports* list box in the *Horvath-Kawazoe Report Options* window, then click **Edit**. Select the data types to include in the report. *Column [n]* indicates the column order and data contents for the report.

ISOTHERM REPORT OPTIONS

The *Isotherm* report indicates adsorption (up to saturation pressure) and desorption (down from saturation pressure) of a gas by a solid held at constant temperature.

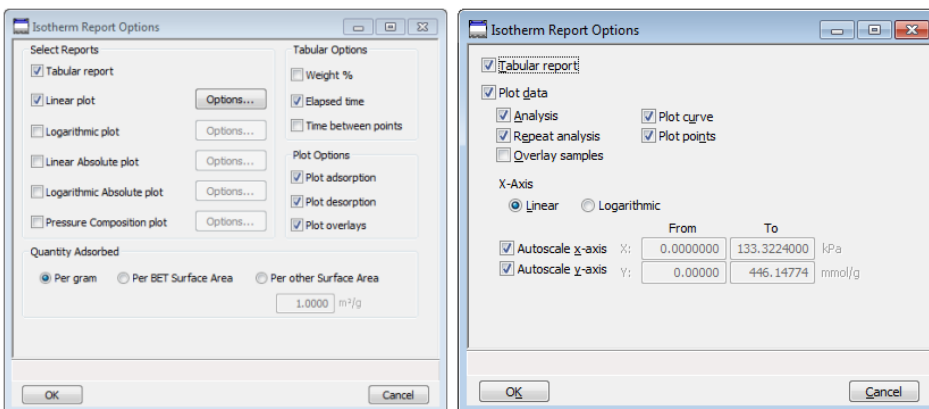





Physical Adsorption

Chemical Adsorption

Isotherm Reports

Field or Button	Description
Autoscale [check box]	<p>Autoscale x-axis. Linear x-axes begin at zero. Logarithmic x-axes begin at an appropriate value. The x-axis field shows the relative or absolute pressure.</p> <p>Autoscale y-axis. The y-axis field shows the quantity of gas adsorbed.</p>
Options [button]	<p>Click to display related linear plot options. All plot windows contain identical fields.</p> <p>Autoscale x-axis. Linear x-axes begin at zero. Logarithmic x-axes begin at an appropriate value. The x-axis field shows the relative or absolute pressure.</p> <p>Autoscale y-axis. The y-axis field shows the quantity of gas adsorbed.</p> <p>Plot curve / Plot points. Select to plot points on the graph.</p>
Plot Data [check box]	Select each option to include in the final report.
Plot Options [group box]	Select the types of isotherm to plot.

Isotherm Reports (continued)

Field or Button	Description
Quantity Adsorbed [group box] 	Select how to report the quantity adsorbed. <ul style="list-style-type: none"> per gram (cm³/g) STP per BET Surface Area (cm³/m²) STP or mmol/g per other Surface Area (cm³/m²) STP or mmol/m²
Selected Reports [group box] 	Select each option to include on the final report. Click the Options button of a selected item to include plot curve, plot points, and to autoscale x- and y-axes.
Tabular Options [group box] 	Select the options to include on the report. <p>Elapsed time. Time elapsed during the analysis.</p> <p>Time between points. Time elapsed between points during the analysis.</p> <p>Weight %. Enter the mass percentage when plotting pressure composition.</p>
Tabular Report [group box] 	Select to include tabular data in the report.
X-axis [group box] 	Indicate if the x-axis should be in linear or logarithmic format.



For fields and buttons not listed in this table, see [Common Fields and Buttons on page 2 - 3](#).

LANGMUIR REPORT OPTIONS

The Langmuir calculation determines the surface area of a sample by relating the surface area to the volume of gas adsorbed as a monolayer. Langmuir uses a single layer model.

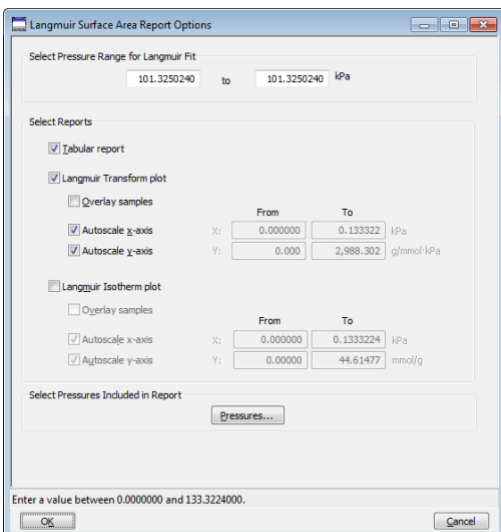

Physical Adsorption

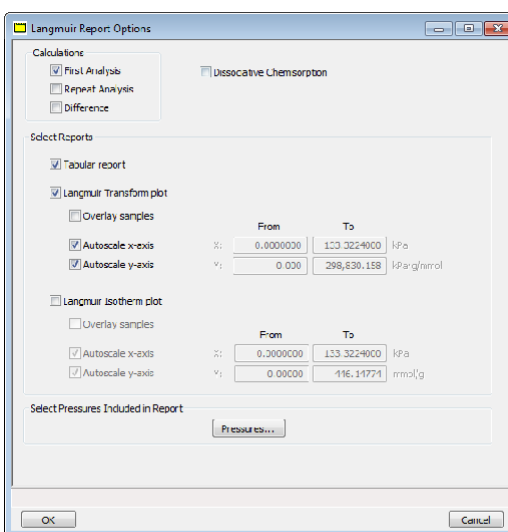

Chemical Adsorption

Langmuir Reports

Field or Button	Description
Calculations [group box]	Select one or more of the calculation options to be used for analysis.
Pressures [button]	Use to enter a range of pressure points to be included in the report or to modify table values for pressure points. <div style="text-align: center; margin: 10px 0;"> </div> <p>Calculation pressure range. Enter the minimum and maximum pressures to be used in the pressure table.</p> <p>Exclude All. Select to exclude all pressure points in the table.</p> <p>Include All. Select to include all pressure points in the table.</p>

Langmuir Reports (continued)

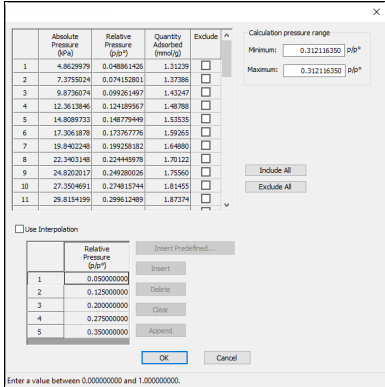
Field or Button	Description
	<p>Line fit pressure range. Enter the minimum and maximum pressures for line fit.</p>
<p>Pressures [button] </p>	<p>This option is available when the sample file has a status of <i>Analyzing</i> or <i>Complete</i>. Use to enter a range of pressure points to be included in the report or to modify table values for pressure points.</p>  <p>Calculation pressure range. Enter the minimum and maximum pressures to be used in the pressure table. To exclude a point from the calculations used to generate the report, select <i>Exclude</i>.</p> <p>Exclude All. Select to exclude all pressure points in the table.</p> <p>Include All. Select to include all pressure points in the table.</p> <p>Use Interpolation. Use to indicate if the system should use the table or interpolated data. This option is available for BET and Langmuir reports only.</p>
<p>Select Pressure Range for Langmuir fit [group box]</p>	<p>Enter values to indicate the fitted pressure range.</p>
<p>Select Reports [group box]</p>	<p>Langmuir Isotherm Plot. Uses the Langmuir monolayer volume and constant to produce an isotherm.</p> <ul style="list-style-type: none"> • Autoscale x-axis. Linear x-axes begin at zero. The x-axis field shows the absolute pressure for Langmuir. • Autoscale y-axis. The y-axis field shows the quantity of gas adsorbed. • Overlay samples. Use to overlay sample files on the Langmuir isotherm plot.

Langmuir Reports (continued)

Field or Button	Description
	<p>Langmuir Transform Plot. Use to generate a traditional Langmuir surface area plot used to determine monolayer volume constant.</p> <ul style="list-style-type: none"> • Autoscale x-axis. Linear x-axes begin at zero. The x-axis field shows the absolute pressure for Langmuir. • Autoscale y-axis. The y-axis field shows Langmuir transformation. • Overlay samples. Use to overlay sample files on the Langmuir transform plot.
	<p>For fields and buttons not listed in this table, see Common Fields and Buttons on page 2 - 3.</p>

MP-METHOD REPORT OPTIONS

The *MP-Method Report Options* provides pore volume distributions for microporous materials by correlating quantity adsorbed with the thickness of the adsorbed layer as determined from a user-selected thickness curve. Pore size can be expressed in angstroms or nanometers. Go to **Options > Units** to specify the unit.

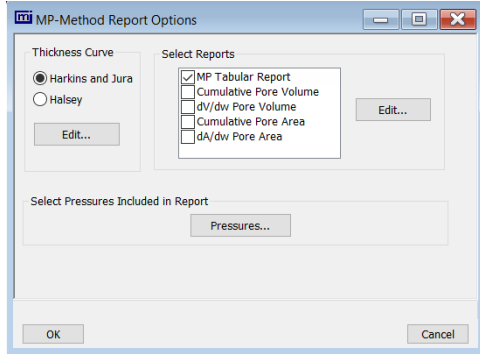

MP-Method Reports

Field or Button	Description
Pressures [button]	<p>Use to select a pressure range for report calculations and points for exclusion from calculations.</p> <p>Calculation pressure range. Enter the minimum and maximum pressures to be used in the pressure table. To exclude a point from the calculations used to generate the report, select <i>Exclude</i>.</p> <p>Exclude All. Select to exclude all pressure points in the table.</p> <p>Include All. Select to include all pressure points in the table.</p>

MP-Method Reports (continued)

Field or Button	Description
Select Reports <i>[group box]</i>	Select the reports to generate. Highlight the report, then click Edit to modify report options.
Thickness Curve <i>[group box]</i>	Select the thickness curve, then click Edit to modify the values in the equation for the selected curve.
	For fields and buttons not listed in this table, see Common Fields and Buttons on page 2 - 3 .

MP-METHOD PLOT REPORT OPTIONS

In the *MP-Method Report Options* window, highlight a plot option in the *Selected Reports* list box, then click **Edit** to customize the plotting method.

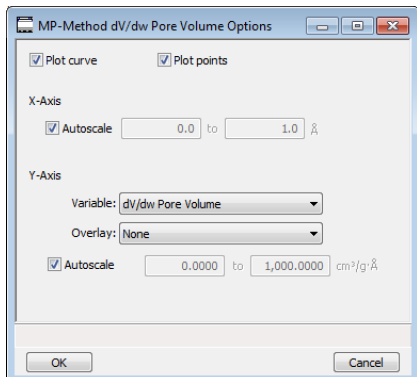

MP Method Plot Reports

Field or Button	Description
Overlay [drop-down box]	Select an option to overlay on the current report.
Plot curve / Plot points [selection]	Select to plot points on the graph.
Thickness Curve [group box]	Select the thickness curve, then click Edit to modify the values in the equation for the selected curve.
X-Axis [check box]	Use to have the x-axis autoscaled or enter beginning and ending values.
Y-Axis [group box]	<p>Autoscale. Use to have the y-axis autoscaled or enter beginning and ending values.</p> <p>Overlay. Select an option to overlay on the current report.</p> <p>Variable. Select a variable.</p>
 <p>For fields and buttons not listed in this table, see Common Fields and Buttons on page 2 - 3.</p>	

MP-METHOD TABULAR REPORT OPTIONS

In the *MP-Method Report Options* window, highlight *MP Tabular Report* in the *Selected Reports* list box, then click **Edit**. *Column [n]* indicates the column order and data contents for the report.

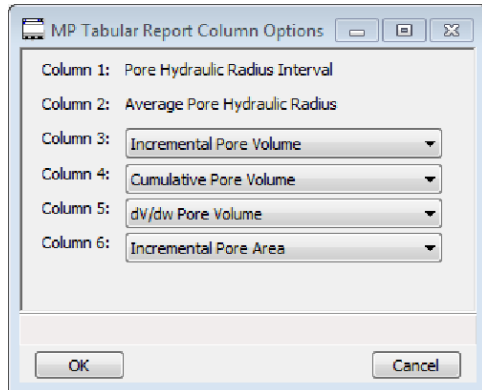

The MP Method reports hydraulic radius only. If Pore size in diameter is selected on the Unit Selection window, pore size in radius will be reported.

NLDFT ADVANCED PSD REPORT

The *NLDFT Advanced PSD* report allows for more advanced computation of the pore size distribution of a material using two separate analyses and two non-local DFT models.

The *NLDFT Advanced PSD* report option provides the same calculations as the DFT Pore Size report option and more. The NLDFT report compares two sample files. The models that can be selected are restricted to only those models which have the same analysis temperature and analysis gas as the sample file that is open. For instance, if the sample file was analyzed with N₂ at 77 degrees Kelvin, then only the N₂ DFT models at 77 degrees Kelvin will be available in the *Model* drop-down list.

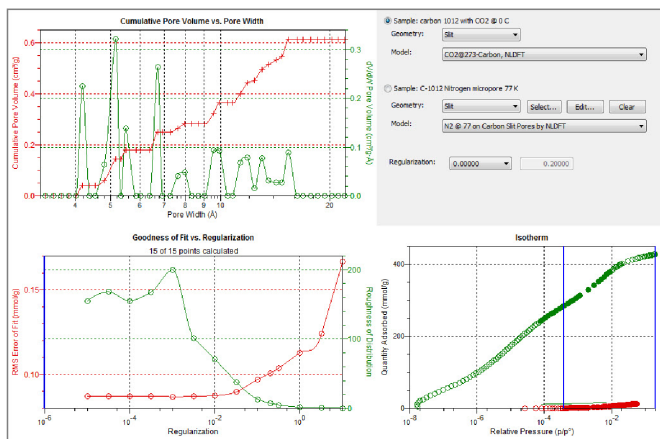

The model curve fit is shown in the lower right quadrant along with the adsorption isotherm. This curve fit is updated each time the calculation parameters change (selection of isotherm data points, choice of model, choice of regularization parameter).

A second sample file and second model is used to compute a more accurate pore size distribution (PSD), which is shown in the upper left quadrant. Typically, the second sample file will have used the same sample material as the first sample file yet will have used a different analysis gas and temperature.

In general, the isotherm for this second sample will be different than the first sample. The advanced DFT calculation takes the data from both sample files and combines all this data into a more accurate calculation of the pore size distribution. More accurate means getting the pore distribution at smaller pore sizes (a few Angstroms) as well as larger pore sizes (one thousand Angstroms).



To make a successful *Advanced* calculation, a second sample file must be selected using the **Select** button. A second model must also be selected. Use the options next to the two sample file names to select the isotherm data points for each sample. After selecting an option, the blue bars in the isotherm graph will be toggled to select either the red points or the green points. Once these selections have been done, the results will appear in the left-hand plots and a second isotherm will appear in the isotherm plot (lower right) as well as a second curve-fit. As the selection of points is adjusted, the DFT editor will recalculate the PSD results and also recalculate the two model curve fits.

NLDFT Advanced PSD Reports

Field or Button	Description
Geometry [drop-down box]	Select the pore shape.
Model [drop-down box]	Lists the models that meet the specified criteria and match the adsorbate and temperature of the sample data. If no models appear, no models meet the selected criteria. One model must be selected.
Regularization [drop-down box]	Select the extent of smoothing to apply to the data. If <i>0.20000 (user)</i> is selected, enter a number in the text box giving a relative mass for the smoothing during deconvolution. Larger values produce more smoothing.
Select Reports [group box]	Use to select the second sample file.



For fields and buttons not listed in this table, see [Common Fields and Buttons on page 2 - 3](#).

To run the NLDFT report:

1. Go to **File > Open**. Select a sample file with a *Complete* status, then click **Open**.
2. In the drop-down list at the bottom of the window, select *NLDFT Advanced PSD*. Graphs for the first sample file display and the sample description shows as the first group box title in the upper right corner of the window.

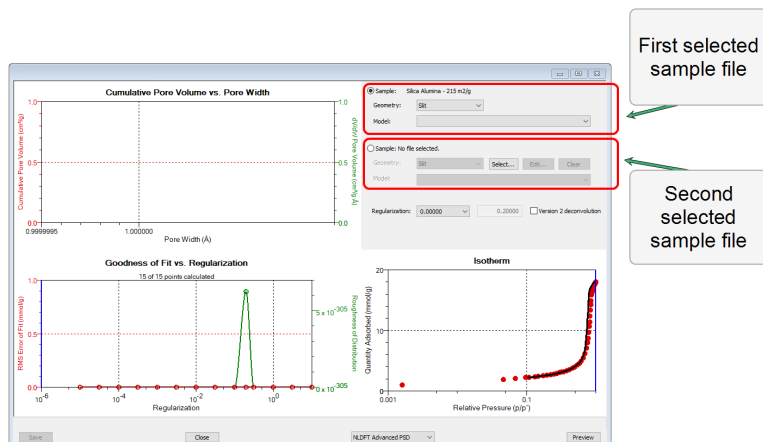

- a. Select the *Geometry* and *Model* from the drop-down lists for the first sample file.
 - b. To select isotherm data points for calculation for the first sample file, ensure the option to the left of the first sample file description is selected. Slide the two blue bars on the isotherm graph to select data points. Without a second sample selected, the report will perform a single model DFT calculation and show the results in the two left-hand result windows.
3. To calculate data from the second sample file, click **Select** to locate and open the second sample file with a *Complete* status. Graphs for the second sample file display and the sample description will display as the second group box title in the upper right corner of the window.
 - a. Select the *Geometry* and *Model* from the drop-down lists for the second sample file.
 - b. To select isotherm data points for calculation for the second sample file, ensure the option to the left of the second sample file description is selected. Slide the two blue bars on the isotherm graph to select data points. Data are automatically calculated for both sample files.
 - c. Click **Edit** to make any necessary modifications to the second sample file.

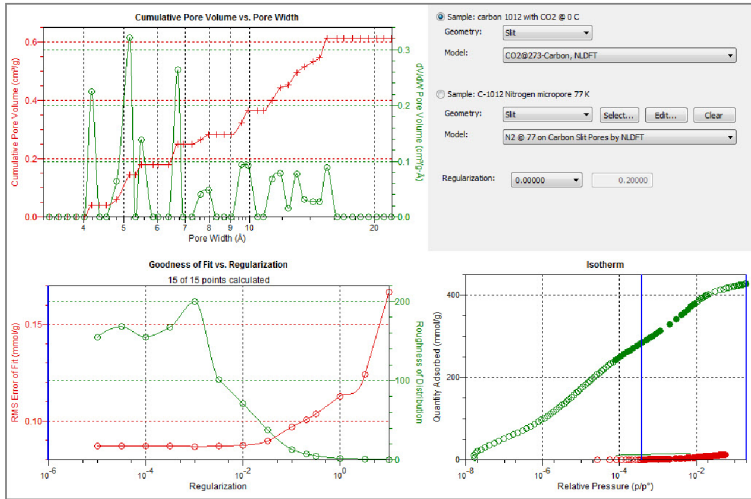

OPTIONS REPORT

Physical Adsorption

Lists the conditions used to perform the analysis— such as:

- Adsorptive properties
- Analysis conditions
- Analysis method
- Degas conditions
- Free space
- Saturation pressure (P_0) and temperature



Options reports cannot be edited.

Chemical Adsorption

Produces a printed report of a predefined collection of sample file parameters. If *Automatically collected* is selected in the *Type of Data* group box on the *Sample Description* tab, the following information is reported:

- **Task Summary.** Lists conditions specified for each task selected.
- **Analysis Task Options.** Details conditions specified for the analysis task.
- **Experiment Log.** Identifies actual conditions under which each task transpired.
- **Leak Test Results.** Identifies outgas rates and the outcome for each leak test performed.

SAMPLE LOG REPORT

This report provides information on:

- Manual control operations performed during analysis.
- Information entered using *Add Log Entry* on the sample file editor.
- Warnings and/or errors which occurred during analysis.

SINFELT AND DIFFERENCE METHODS FOR CHEMICAL ADSORPTION**See also:**

[*Difference Method Report Options for Chemical Adsorption on page 8 - 15*](#)

The *Difference Method Report* and the *Sinfelt Method Report* windows are identical unless otherwise specified.

SUMMARY REPORT OPTIONS

The *Summary Report* for physical adsorption analyses provides a condensed summary of selected data results.

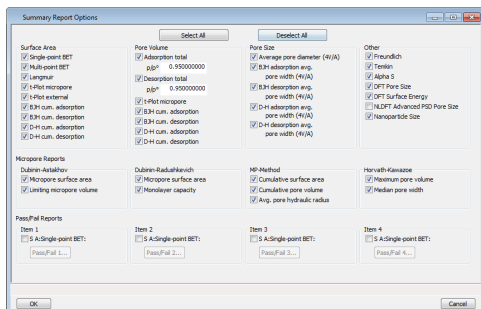

In the *Pore Volume* group box, if *Adsorption total* or *Desorption total* is selected, the p/p^0 field is enabled. Enter the relative pressure used to calculate the total pore volume.

Summary Report

Field or Button	Description
Item [n] [selection]	<p>Use to enable the first <i>Pass/Fail</i> item. Until the <i>Summary Report</i> is selected, <i>S A Single-point BET</i> will be displayed by default. When selected, click Pass/Fail, then select pass/fail criteria options.</p> <p>Pass/Fail [n]. Click to display the <i>Pass/Fail Options</i> window for selection of pass/fail criteria.</p>
	<p>S A: Single-point BET. Use to enable Pass/Fail [n] in the <i>Item [n]</i> group box.</p>

Summary Report (continued)

Field or Button	Description
	Upper/Lower. Specify upper and lower limits for the selected parameter. A range can be left open by not selecting the limit. In the text box to the right of <i>Upper / Lower</i> , enter operator instructions to be displayed if a failure is encountered.
Select All / Deselect All <i>[button]</i>	Selects (or deselects) all options.
	For fields and buttons not listed in this table, see Common Fields and Buttons on page 2 - 3 .

T-PLOT REPORT OPTIONS

The *t*-Plot calculation allows quantitative analysis of the area and total volume ascribed to micropores. Matrix area (the area external to micropores) is directly determined and often proves to be a valuable way of characterizing complex mixed materials.

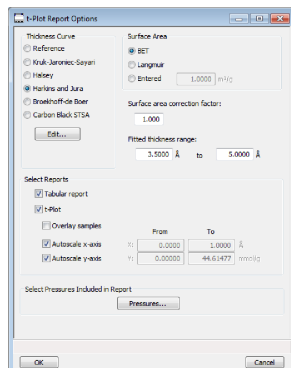

t-Plot Reports

Field or Button	Description
Fitted thickness range [text box]	Enter the minimum and maximum thicknesses (in angstroms or nanometers) to include in the thickness curve. Go to Options > Units to specify default units.
Pressures [button]	Use to select a pressure range for report calculations and points for exclusion from calculations. <div style="border: 1px solid black; padding: 5px; margin: 10px 0;"> </div> <p>Calculation pressure range. Enter the minimum and maximum pressures to be used in the pressure table. To exclude a point from the calculations used to generate the report, select <i>Exclude</i>.</p> <p>Exclude All. Select to exclude all pressure points in the table.</p> <p>Include All. Select to include all pressure points in the table.</p>

t-Plot Reports (continued)

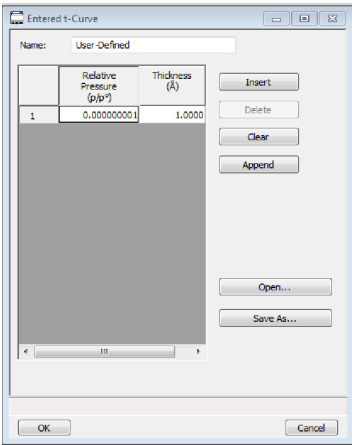
Field or Button	Description
Selected Reports <i>[group box]</i>	<p>Tabular Report. Use to have a tabular report of data generated.</p> <p>t-Plot. Use to have a graphical representation of data generated.</p> <ul style="list-style-type: none"> • Autoscale x-axis. The x-axis field shows the statistical thickness of the adsorbed film. • Autoscale y-axis. The y-axis field shows the quantity of gas adsorbed. • Overlay samples. Use to overlay sample files on the t-plot.
Surface area correction factor <i>[text box]</i>	Enter the value to correct for surface areas that are not smooth. This brings the values for BET surface area and micropore surface area into accordance. For most samples, the default value of 1.000 is adequate.
Surface Area <i>[group box]</i>	Select the surface area value used for thickness calculations. BET is the most commonly used option.
Thickness Curve <i>[group box]</i>	<p>Select the thickness curve, then click Edit to modify the values in the equation for the selected curve. The Frenkel-Halsey-Hill thickness curve can be applied using the Halsey option.</p> <p>Kruk-Jaroniec-Sayari / Halsey / Harkins and Jura / Broekhoff-de Boer / Carbon Black STSA. Select the thickness curve option, then click Edit. Modify the equation for the selected curve as needed.</p> <p>Reference. Select <i>Reference</i>, then click Edit to define a t-curve by entering both the relative pressure and thickness values. One predefined curve is shipped with the analysis program and is found in the <i>Reference</i> directory.</p> 

t-Plot Reports (continued)

Field or Button	Description
	To import values from an existing thickness curve (.THK file), click Open , then select the file containing the values. The table to be imported must have a .TXT or .THK file extension and have a two-column format with the relative pressures in the first column and the thickness values in the second column. Columns must be separated by a space or a tab.
t-Plot <i>[checkbox]</i>	<p>Use to have a graphical representation of data generated.</p> <p>Autoscale x-axis. The x-axis field shows the statistical thickness of the adsorbed film.</p> <p>Autoscale y-axis. The y-axis field shows the quantity of gas adsorbed.</p> <p>Overlay samples. Use to overlay sample files on the t-plot.</p>
	<p>For fields and buttons not listed in this table, see Common Fields and Buttons on page 2 - 3.</p>

TEMKIN REPORT OPTIONS

The *Temkin* isotherm is used to model adsorption data where the heat of adsorption drops linearly with increasing coverage.

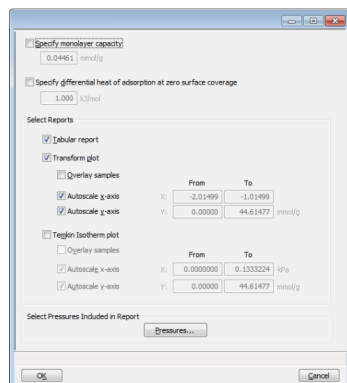

Physical Adsorption

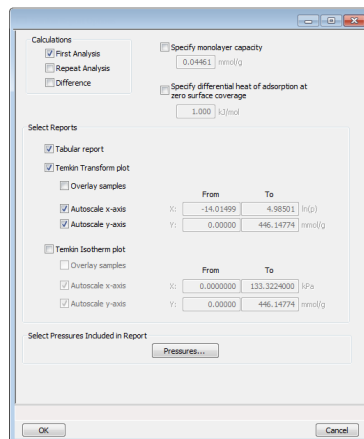

Chemical Adsorption

Temkin Reports

Field or Button	Description
Calculation [group box]	Select one or more of the calculation options to be used for analysis.
Pressures [button]	Use to select a pressure range for report calculations and points for exclusion from calculations. Enter a value between 0.000000000 and 1.000000000. Calculation pressure range. Enter the minimum and maximum pressures to be used in the pressure table. To exclude a point from the calculations used to generate the report, select <i>Exclude</i> . Exclude All. Select to exclude all pressure points in the table. Include All. Select to include all pressure points in the table.

Temkin Reports (continued)

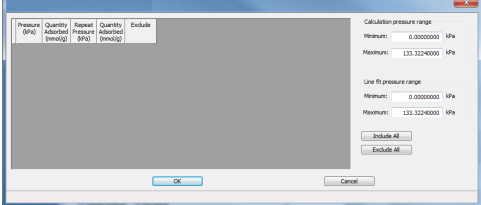
Field or Button	Description
<p>Pressures [button] </p>	<p>Use to enter a range of pressure points to be included in the report or to modify table values for pressure points.</p>  <p>Calculation pressure range. Enter the minimum and maximum pressures to be used in the pressure table.</p> <p>Exclude All. Select to exclude all pressure points in the table.</p> <p>Include All. Select to include all pressure points in the table.</p> <p>Line fit pressure range. Enter the minimum and maximum pressures for line fit.</p>

Temkin Reports (continued)

Field or Button	Description
Select Reports <i>[group box]</i>	<p>Tabular Report. Generates a tabular report of the included samples. A tabular report contains the numeric values contributed by each sample.</p> <p>Temkin Isotherm plot. Overlays the Temkin isotherm with the analysis data.</p> <ul style="list-style-type: none"> • Autoscale x-axis. Linear x-axes begin at zero. The x-axis field shows the absolute pressure. • Autoscale y-axis. y-axes begin at zero. The y-axis field shows the quantity of gas adsorbed. • Overlay samples. Use to overlay sample files on the isotherm plot. <p>Temkin Transform plot. Plots a linear form of the Temkin transform plot.</p> <ul style="list-style-type: none"> • Autoscale x-axis. The x-axis field shows the logarithm of pressure (ln). • Autoscale y-axis. The y-axis field shows the quantity of gas adsorbed. • Overlay samples. Use to overlay sample files on the transform plot.
Specify differential heat of adsorption <i>[check box]</i>	Select and enter the differential heat of adsorption at zero surface coverage. This allows inclusion of all Temkin constants.
Specify monolayer capacity <i>[check box]</i>	Select and enter the monolayer capacity of the sample.
<div style="border: 1px solid green; padding: 5px;">  <p>For fields and buttons not listed in this table, see Common Fields and Buttons on page 2 - 3.</p> </div>	

VALIDATION REPORT OPTIONS

This report allows data to be examined by the analysis program to determine if the results are within typical ranges. If the data for any reports selected for validation are determined to be out of range, a warning will display and suggestions are given for corrective action. This information is detailed in the report and plotted on the graph as a unique plot symbol.

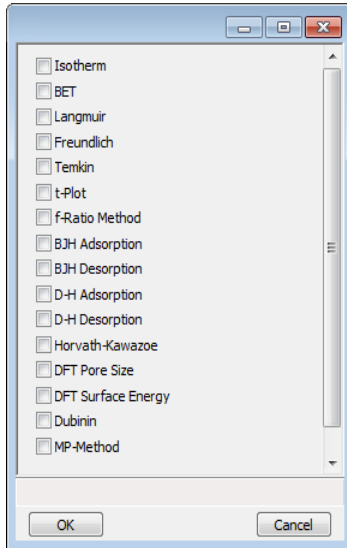

9 DIAGNOSTICS

Unit [n] > Diagnostics

Use to display diagnostic readings, start and schedule diagnostic tests, and open saved diagnostic reports. Each test generates a file to the default directory name and path of ...\\...\\Service\\userdiag unless another directory name was specified. These reports can be sent to a Micromeritics Service Representative for examination.

START DIAGNOSTIC TEST

Unit [n] > Diagnostics > Start Diagnostic Test

Provides a method to start a diagnostic test immediately. Upon completion of the diagnostic test, the file is saved as a .REP file which can be retrieved by going to **Reports > Open Report** and selecting the report file.



It is recommended to schedule the *Analysis Manifold Leak Test* and the *P₀ Port Leak Test* to run unattended on a weekly basis. These tests check for system leaks and require no operator intervention.



The *P₀ Port Leak Test* should only be run if the Psat tube is attached. If a vapor source is attached, this test should not be run.

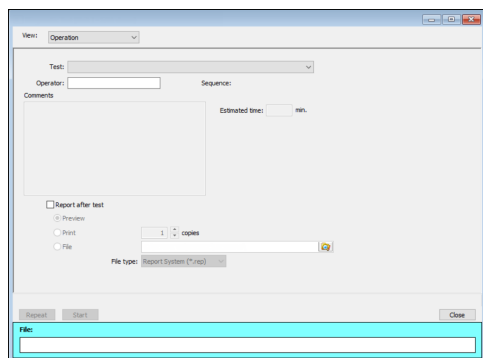

Start Diagnostic Test

Field or Button	Description
Comments [text box]	Displays comments from the selected diagnostic test.
Estimated time (min.)	Approximate time for test completion.
File [group box]	Shows a status bar of steps complete once the test begins.
Next [button]	Starts the next test.

Start Diagnostic Test (continued)

Field or Button	Description
Operator <i>[text box]</i>	Enter information to identify the person running the service test.
Repeat <i>[button]</i>	Repeats the selected diagnostic test.
Report after test <i>[check box]</i>	Automatically generates reports to the selected destination when the test is complete.
Sequence	Sequence number assigned to the test.
Start <i>[button]</i>	Starts the diagnostic test.
Test <i>[drop-down box]</i>	Select the diagnostic test to be performed.



For fields and buttons not listed in this table, see [Common Fields and Buttons on page 2 - 3](#).

SCHEDULE DIAGNOSTIC TESTS

Unit [n] > Diagnostics > Schedule Diagnostic Tests

Allows the specification of one-time or periodic running of a sequence of diagnostic tests. A separate list of tests is saved for each of the possible test frequencies. Tests are categorized and flagged as requiring intervention or not. If tests requiring intervention are scheduled, the operator has the option of omitting the tests if the operator does not respond within a specified time after an initial prompt is displayed and before the test is started. Events are logged in the analyzer log for all starting, ending, and omitted tests.

Schedule Diagnostics Test Frequency

Field or Button	Description
Available Tests <i>[drop-down box]</i>	Select one or more tests to run unattended.
Insert <i>[button]</i>	Inserts the selected test in the <i>Available Tests</i> drop-down list.
Skip these tests if the operator does not respond within [n] minutes <i>[checkbox]</i>	Check this option if any test requiring operator intervention should be omitted if the operator does not respond within the specified time.
Start test sequence if instrument is idle any time between 00:00:00 and 00:00:00 <i>[text box]</i>	Enter a from and to time for an unattended test to begin if the instrument is idle at any time during the entered time frame.
Test Frequency <i>[selection]</i>	Select how often the test is to run unattended.

Schedule Diagnostics Test Frequency (continued)

Field or Button	Description
<p>Test Sequence [group box]</p>	<p>Provides the test file identification and estimated run time. A checkmark in the <i>Intervention Required</i> column indicates that operator intervention is required.</p> <p>To remove a test from the sequence, select the test, then click Delete.</p> <p>To add a test to the test sequence, highlight a row in the <i>Test Sequence</i> box, select a test from the <i>Available Tests</i> list, then click Insert.</p>
<div style="border: 1px solid black; padding: 5px;">  <p>For fields and buttons not listed in this table, see Common Fields and Buttons on page 2 - 3.</p> </div>	

DIAGNOSTIC TEST REPORT

Unit [n] > Diagnostics > Diagnostic Test Report

Displays previously run diagnostic service tests. Separate directories store tests run once, daily, weekly, and monthly. Diagnostic test report files have a .SVT file extension and are stored in the ...\\Service directory.

SAVE FILES FOR PROBLEM DIAGNOSIS

Unit [n] > Diagnostics > Save Files for Problem Diagnosis

Use to compress pertinent diagnostic information into a single zip file. This file can be sent to a Micromeritics Service Representative for problem resolution.

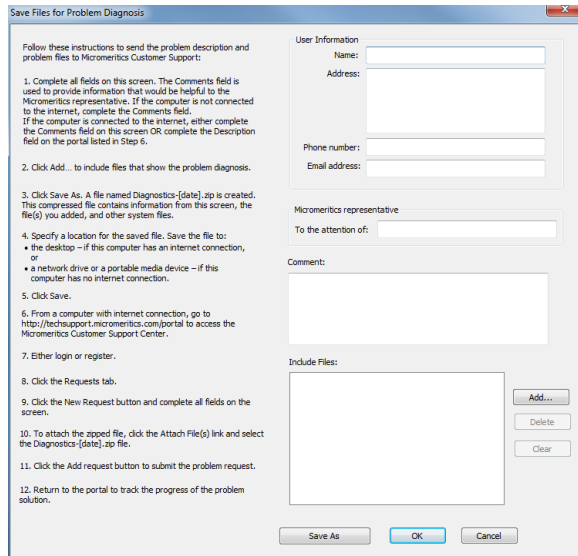

1. Complete the form. A default file named *Diagnostics-[date].zip* is created unless another file name is specified.
2. When the file is saved, log in to the [customer portal](#).
3. Click the *Requests* tab.
4. Click **New Request**, then complete all fields.
5. To attach the zipped file, click the *Attach File(s)* link, then select the *Diagnostics-[date].zip* file.
6. Click **Add Request** to submit the problem request.
7. Return to the portal to track the progress of the problem solution.

Save Files for Problem Diagnostics

Field or Button	Description
Comment [text box]	Enter information that would be helpful to the Micromeritics representative. If the computer is not connected to the internet, complete this field. If the computer is connected to the internet, this information can be completed on the Micromeritics Customer Support portal.

Save Files for Problem Diagnostics (continued)

Field or Button	Description
Include Files	<p>Add. Click to select additional files to send with this problem diagnosis.</p> <p>Delete. Select the file in the <i>Include Files</i> box, then click Delete to remove the file from the list.</p> <p>Clear. Click to clear all files from the <i>Include Files</i> box.</p>
Save As [button]	Click to specify the name and location of the compressed file. Make a note of the file name and location. This file will need to be sent to your Micromeritics representative for problem resolution.
Micromeritics representative [text box]	Enter the name of your Micromeritics representative. This information will remain on the window each time files for problem diagnosis need to be submitted (can be modified as necessary).
User Information [text box]	Enter information for the person to be contacted by a Micromeritics representative. This information will remain on the window each time files for problem diagnosis need to be submitted (can be modified as necessary).

For fields and buttons not listed in this table, see [Common Fields and Buttons on page 2 - 3.](#)

SHOW ALL READINGS

Unit [n] > Diagnostics > Show All Readings

The *Show All Readings* window displays the calibrated and nominal readings of all sensors in the system.

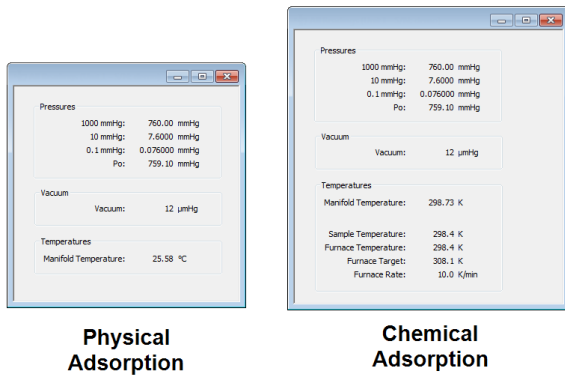

10 CALIBRATION



Service Test Mode is required for this test. See [Service Test Mode on page 12 - 8](#).

A calibration file was created specifically for the analyzer and included with the accessories. It is not necessary to recalibrate the system unless it seems out of calibration.

Disabled calibration menu options can be accessed only with the assistance of an authorized Micromeritics Service Representative. Calibrations can be saved to a file and reloaded later.

To review calibration details of the analyzer, go to **Unit [n] > Unit Configuration**.

Generally it will not be necessary to change the data in the calibration file. However, if a condition occurs during the operational verification that requires changes to the calibration data, changes should be saved in a file. Calibration data files are retained in the analyzer history file and can be reloaded in the event that calibration data becomes corrupt.

CALIBRATE FURNACE RESISTANCE

Unit [n] > Calibration > Furnace Resistance

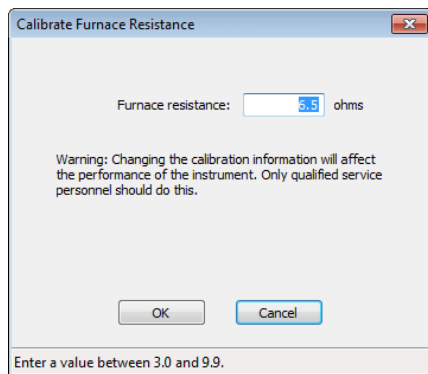

Calibrating the furnace resistance will affect the performance of the instrument. Only qualified service personnel should perform this operation.

Use this feature to calibrate the furnace resistance. Enter the ohms, then click **OK**.

CALIBRATE PRESSURE ZERO

Unit [n] > Calibration > Pressure Zero

This procedure evacuates the system and zeroes the pressure transducers. This calibration should only be performed by qualified service personnel. In order to perform this procedure, sample tubes must be attached to each port.

The system automatically zeros the transducers before an analysis begins. Therefore, this procedure may not need to be performed unless operating the system in manual mode. If *Include P₀ transducer* is selected, the P₀ port will be evacuated and the transducer zeroed with the analysis manifold transducers.

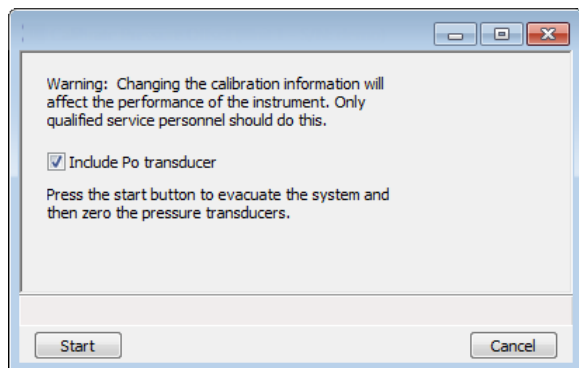

LOAD CALIBRATION FROM FILE

Unit [n] > Calibration > Load from File

Use to load a previously saved calibration file.

It is recommended that the current calibration settings be saved using **Unit [n] > Calibration > Save to File** prior to loading another calibration file. When loading a previously saved calibration file, a backup of the current file is created and saved as *[SN]ast.cal*. The backup file is overwritten each time a new one is created.



Changing the calibration may affect the analyzer's performance.

SAVE CALIBRATION TO FILE

Unit [n] > Calibration > Save to File

Use to save the current calibration settings to a backup file which can later be reloaded using the **Unit [n] > Calibration > Load from File** menu option.

The default file naming convention for calibration files can be used or the file name can be changed. The default file name of 0217-2013-04-25.CAL is interpreted as:

0217	is the analyzer serial number
2013-04-25	is the date the calibration file was saved
.CAL	is the file name extension

Blank Page

11 HARDWARE

COLD TRAP OPTION

COLD TRAP DEWAR INSTALLATION



See also:

[Dewar Precautions on page 6 - 1](#)



Cryogenics can cause frostbite injury. Wear safety glasses and insulating gloves when handling cryogenics.

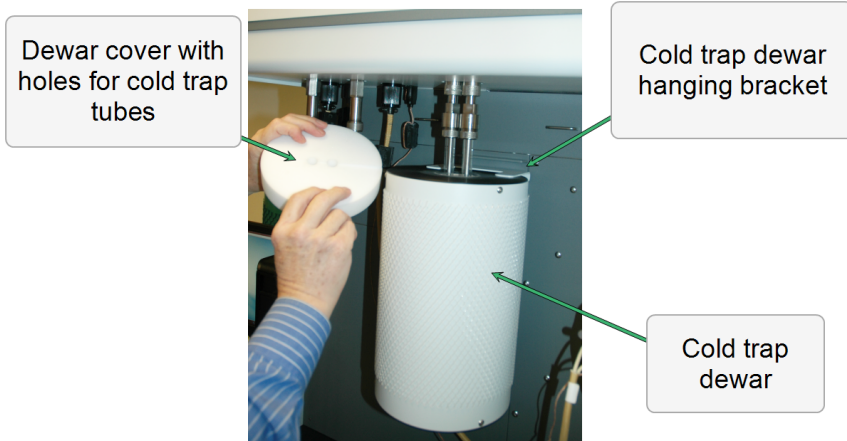

1. Fill the cold trap dewar with a cryogen (such as liquid nitrogen) to approximately 2 in. (5 cm) from the top.
2. Place the cold trap dewar below the cold trap tubes and gently slide the dewar up around the cold trap tubes.
3. Hang the bracket on the top of the dewar onto the bracket behind the cold trap tubes.
4. The insulated dewar cover has a slot and two holes for the cold trap tubes. Gently open the slot and slide the dewar cover around the two cold trap tubes.
5. Hang the safety shield around the cold trap dewar.

COLD TRAP TUBE INSTALLATION

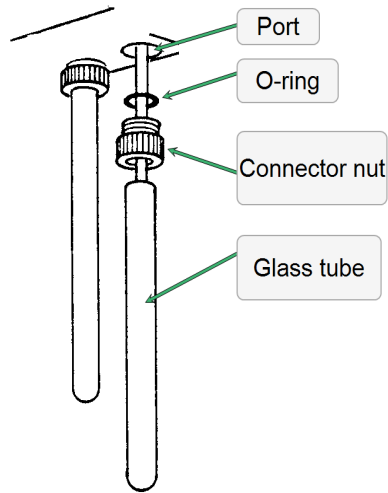

1. Remove the cold trap connector nut and O-ring.
2. Place the cold trap connector nut and O-ring on the cold trap tube.
3. Slide the cold trap tube up around the metal tube and secure it with the O-ring and connector nut.

FURNACE

CHEMICAL ADSORPTION PORT ASSEMBLY

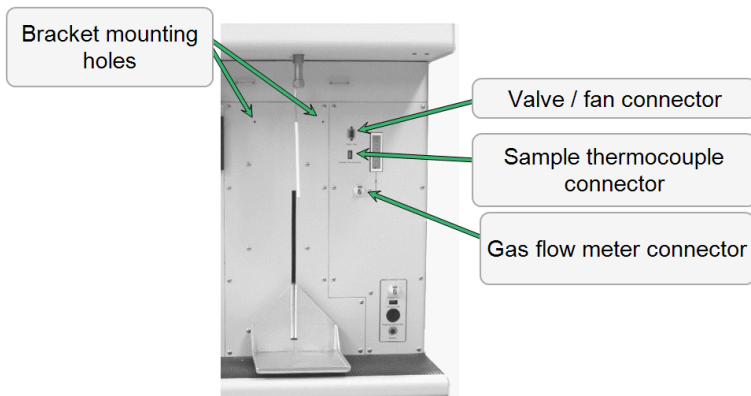

1. Locate the two bracket mounting holes on the elevator panel. If there are screws in the mounting holes, remove them.
2. Position the chemical adsorption port assembly behind the P_0 tube and align the two holes on the back of the furnace assembly shelf with the two mounting holes on the elevator panel.
3. Insert thumb screws into the mounting holes. Turn the screws clockwise and tighten with a flat-blade screwdriver.

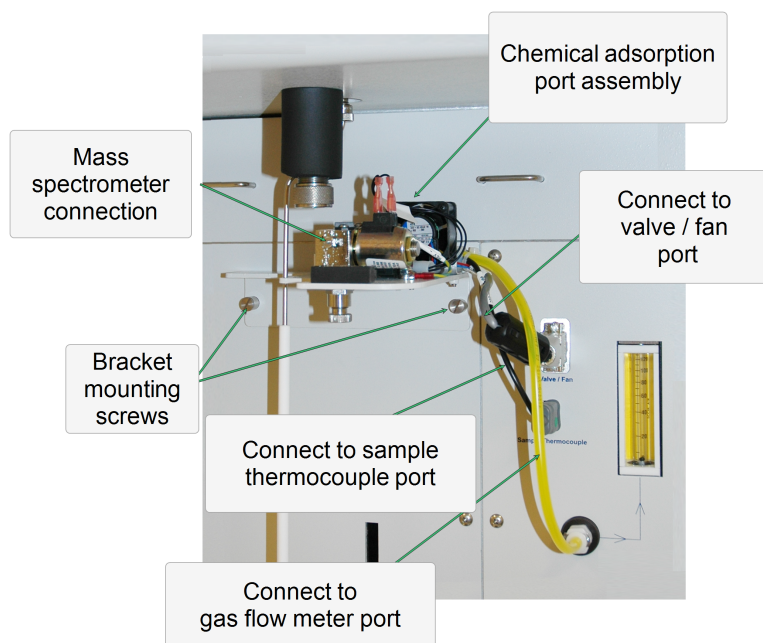

4. Attach the fan cable to the *Valve / Fan* port. If connecting the electronic trigger signal to a mass spectrometer, the Mass Spec Interface Cable (part number 202-60815-00) should be used. It

has a 25 pin D connector for the mass spec electronic trigger signal in addition to the valve and fan signals.

5. Attach the sample thermocouple cable to the *Sample Thermocouple* port.
6. Ensure that the exhaust port is properly connected to safely exhaust hazardous gases.
7. Attach the gas flow tubing to the *Gas flow meter* port.

ATTACH THE FURNACE



A supply of dry, clean, house / compressed air should be available to attach to the furnace for cooling. The air pressure should be well regulated and adjustable at pressures less than 20 psig at the outlet.

1. Place and center the furnace on the elevator.
2. Insert the furnace power cable into the power connector. Twist the power cable to lock into place.
3. Connect the furnace thermocouple plug to the *Thermocouple* connector.
4. Connect the cooling gas tube to the *Cooling Gas* connector.

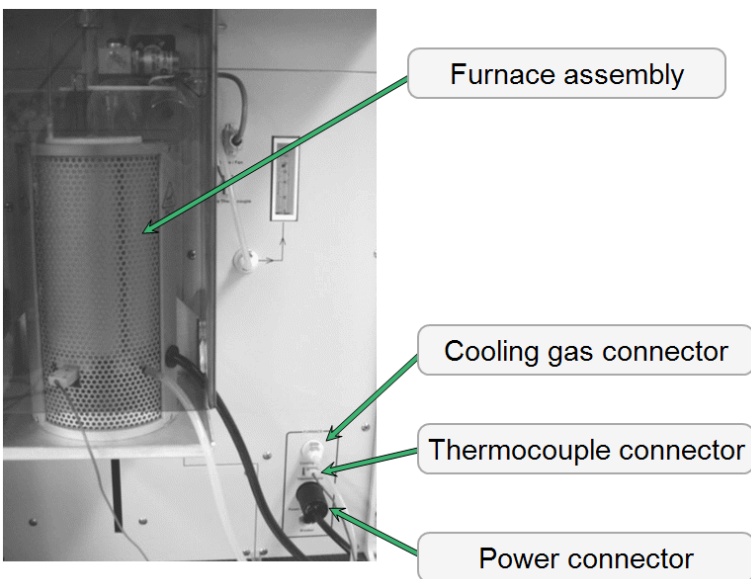

5. Connect a hose from the house / compressed air supply to the furnace cooling gas inlet located on the side panel of the analyzer.

Ensure the supply gas is set at 5 psig (35 kPag). If the pressure is below 3 psig (20 kPag) or above 10 psig (70 kPag), the furnace controller may not be able to control the stability of ramping, or may be unable to cool the furnace within a reasonable amount of time.



Do not allow the pressure to exceed 20 psig (140 kPag). Pressures higher than 20 psig may cause the internal tubing fittings to fail.

6. Connect an exhaust hose to the *Exhaust Hose* port on the right side panel. The exhaust must vent safely to an exhaust hood or other venting system.

HEATING MANTLE INSTALLATION



Ensure there is no isothermal jacket installed on the sample tube. The heating mantle will melt the isothermal jacket.

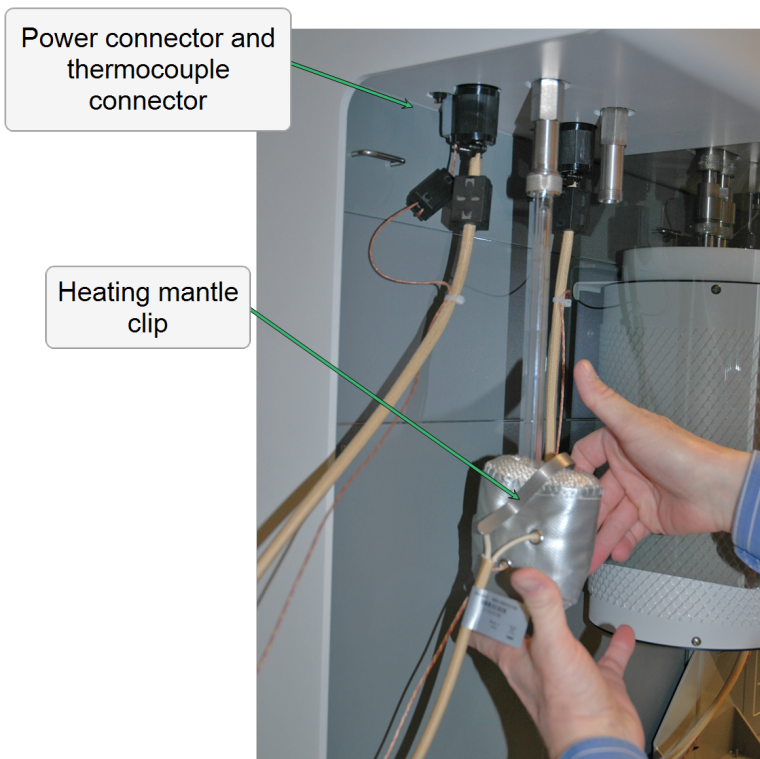

1. Ensure no isothermal jacket is installed on the sample tube.
2. Insert the mantle thermocouple and the mantle power plug into the underside of the analyzer front panel.
3. Place a heating mantle over the sample tube bulb and secure the mantle in place with a mantle clip.

MASS SPECTROMETER INSTALLATION

The mass spectrometer is attached to a bracket that rigidly installs on a Micromeritics chemical adsorption analyzer.

1. Directly above the outlet side of the sample tube connector are two black rails which permit flexibility in the position of the connector. Remove the two screws holding the outer rail and replace it with the bracket.
2. Slide the hose of the mass spectrometer into the cylindrical cavity of the bracket and secure in place by tightening the clamp around the cavity.
3. The small gas conducting capillary coming from the center of the larger hose connects into the system through a port in front of the larger hose. Remove the fitting by unscrewing it and set the plug aside.
4. The connecting capillary can be either of glass, stainless steel, or of glass protected by a plastic tube. Insert the capillary through the fitting and place an appropriate ferrule on it. Screw the fitting into the port.
5. Tighten the fitting securely.

SAMPLE TUBE INSTALLATION



See:

[*Sample Tube Installation on page 6 - 16*](#)

12 TROUBLESHOOTING AND MAINTENANCE

The analyzer has been designed to provide efficient and continuous service; however, certain maintenance procedures should be followed to obtain the best results over the longest period of time. When unexpected results occur, some common operational problems not indicated on the window and their respective causes and solutions are provided:

Log in to your [customer portal](#) to access error messages. Parts and accessories can be found online at www.Micromeritics.com.

Elevator cannot be raised or lowered.

Cause: Elevator is stuck.

Action: Check for possible obstruction to elevator movement.

Elevator is noisy.

Cause: The elevator screw may need greasing.

Action: Contact your Micromeritics Service Representative.

Analysis valves cannot be operated.

Cause A: Circuit opened by circuit breaker.

Action A: Reset breaker (depress **Breaker** button) located on the right side of the instrument beneath the tray cover. See [Analyzer Components for ASAP 2020 on page 1 - 1](#). If the circuit breaker trips (pops out), call your Micromeritics Service Representative.

Cause B: Cable from computer to the instrument is loose.

Action B: Ensure the cable is seated properly.

Vacuum pump gurgles continuously.

Cause A: Sample tube or cold trap tube O-ring or fitting loose.

Action A: Tighten fitting. Replace O-ring.

Cause B: Sample tube cracked.

Action B: Replace with new sample tube.

Cause C: No sample tube loaded on a selected port.

Action C: Install plug or empty sample tube.

Cause D: Gas inlet valve open while vacuum valve open.

Action D: On the schematic, right click on the open valve and select *Close*.

Vacuum gauge shows reading above 20 mmHg, even after extended pumping through unrestricted valve with analysis or degas ports closed.

Cause A: Vacuum pump oil is low, causing ineffective evacuation.

Action A: Add or change vacuum pump oil. Add oil to proper level according to oil level window.

Cause B: Cold trap obstructed by condensation.

Action B: Clean the cold trap tube. See [Clean the Cold Trap Tube on page 12 - 12](#).

Cause C: Filter in port being used is dirty.

Action C: Replace filter in port. See [Replace Port Filters on page 12 - 14](#).

Cause D: Leak in vacuum plumbing.

Action D: Check and tighten all connections in vacuum plumbing, including cold traps.

Cause E: Vacuum pump powered off or unplugged.

Action E: Check pump power plug and power switch.

Cause F: The alumina in the oil vapor trap is holding moisture.

Action F: Replace or dry the alumina. Log in to your [customer portal](#) to access the Vacuum Pump Guide.

Cause G: Filter in port being used is dirty.

Action G: Replace filter in the port. See [Replace the Analysis Port Filter on page 12 - 14](#).

Cause H: Dry forepump needs to be serviced.

Action H: Replace the diaphragms.

GUIDELINES FOR CONNECTING GASES

- Place gas cylinders within 6 feet (2 m) of the gas inlets of the analyzer. Using gas line extenders on gas cylinders located in remote areas may degrade gas quality and reduce pressure. Gas lines are typically five to six feet long. Place the cylinders close enough to allow for proper connection at the analyzer inlet.
- Use a retaining strap (or other appropriate tether) to secure the gas cylinder.
- Always use the gas lines provided with the analyzer. It is very important that proper gas lines are used with the analyzer.
 - **Do not use** polymer tubing for the gas line.
 - **Do not use** flexible gas lines. Some flexible lines may appear to be appropriate, such as those with a herringbone covering, but the line may be coated internally with a polymer.
- Long gas lines, such as those used with gas cylinders placed in remote areas, must be evacuated for an extended period of time to remove ambient gases. When possible, avoid placing gas cylinders in remote locations. It is always best to have gas cylinders located near the analyzer.
- Carefully route the gas lines from the cylinder to the analyzer avoiding overlapping or entangling gas lines. This will help avoid confusion when maintenance is required.
- Label the gas line at the analyzer inlet for proper identification and maintenance.
- Replace gas cylinders before gas is depleted. It is best to replace a gas cylinder when the pressure reads approximately 500 psi (3500 kPa) on the high pressure gauge. Contaminants absorbed to the walls of the cylinder will desorb as the pressure decreases.
- Ensure the gas cylinder is closed before connecting to the analyzer.



To use oxygen, the analyzer must be equipped with an oxygen-compatible vacuum pump that uses Fomblin[®] (or a suitable equivalent) pump oil or a dry forepump. Failure to use the proper vacuum system could result in hazardous conditions, including fire and personal injury.

REPLACE A GAS CYLINDER



These instructions apply to working with inert gases only. When working with hazardous gases, follow the safety procedures established by your lab.

A power failure or loss of cryogen can result in dangerous pressures in the sample chamber. When using toxic or flammable gases, additional venting of the cabinet may be required.

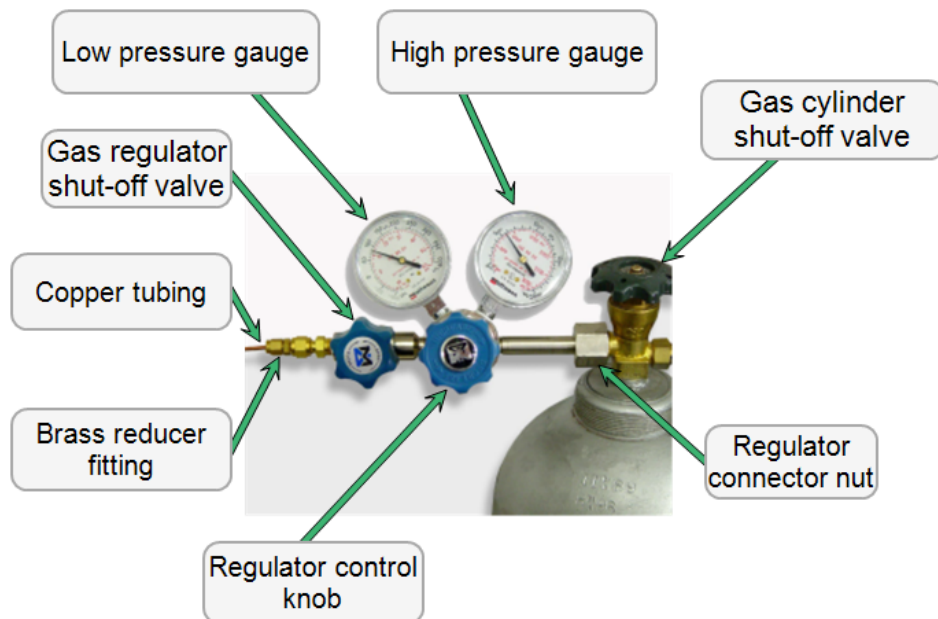

DISCONNECT THE DEPLETED GAS CYLINDER

1. Close the regulator shut-off valve and gas cylinder shut-off valve by turning the knobs clockwise.
2. Disconnect the gas line from the regulator. Gas will be vented from the line. It is not necessary to disconnect the gas line from the analyzer inlet if the cylinder will be replaced immediately with one of the same type.
3. Open the gas regulator shut-off valve by turning the knob counter-clockwise. Gas will be vented from the regulator.
4. Turn the regulator control knob clockwise to open and vent any remaining gas. Both gauges should read at or near zero. If not, make sure the gas regulator shut-off valve is open.
5. Close the regulator by turning the control knob counter-clockwise.
6. Use an appropriate wrench to loosen the nut at the regulator connector nut then remove the regulator from the cylinder.
7. Replace the protective cap on the depleted cylinder. Disconnect the retaining strap and move the cylinder to an appropriate location.

CONNECT A GAS CYLINDER

Regulator Pressure Settings

Analyzer Series	Gauge should indicate
3Flex	15 psig (103 kPag)
AccuPyc	25 psig (172 kPag)
ASAP	15 psig (103 kPag)
AutoChem	15-18 psig (103 - 124 kPag)
AutoPore	50-60psig (345 - 404 kPag)
Gemini	15-18 psig (103 - 124 kPag)
TriStar	15-18 psig (103 - 124 kPag)

Move the replacement cylinder close to the analyzer and tether it into place.

1. Use an appropriate cylinder wrench to remove the protective cap from the replacement gas cylinder. Place the protective cap in a secure location. It will be needed to recap the gas cylinder when it is depleted and replaced.
2. Attach the gas regulator to the gas cylinder connector. Hand tighten the nut, then use an appropriate wrench to tighten an additional 3/4 turn.



Over-tightening the fitting may cause a leak.

3. Check for leaks at the high-pressure side of the regulator and in the connector.
 - a. Turn the regulator control knob fully counter-clockwise.
 - b. Slowly open the gas cylinder shut-off valve, then quickly close it.
 - c. Observe the pressure on the high-pressure gauge for approximately one minute:
 - If the pressure is stable, proceed with the next step.
 - If the pressure decreases, tighten the regulator connector nut until it becomes stable. If the pressure does not remain stable, remove the regulator and clean all contacts at the regulator connection, then reinstall the regulator.
4. Purge the air from the lines.



Purge the regulator before proceeding to prevent contamination of the analysis gas supply.

- a. Open the gas cylinder valve to pressurize the regulator, then close the valve.
- b. Adjust the *Pressure Control* knob to approximately 5 psi.

- c. Turn the regulator *Shut-off* valve counter-clockwise to open. Allow gas to flow until both gauges read approximately zero.
 - d. Close the regulator *Shut-off* valve to stop gas flow.
 - e. Reconnect the gas line to the regulator.
 - f. Use two 7/16 in. (11 mm) wrenches to tighten the gas line connection. Hold one wrench fitting steady and the other to tighten the connector nut.
5. Set the analyzer pressure.
 - a. Turn the *Regulator Control* knob clockwise until the low pressure gauge indicates the appropriate pressure. See [Regulator Pressure Settings on the previous page](#).
 - b. Open the regulator *Shut-off* valve.
 - c. Open the gas cylinder *Shut-off* valve and flow gas for 10 to 30 seconds.
 - d. Close the gas cylinder *Shut-off* valve.
 - e. Close the gas cylinder valve.
 6. If the gas line to the instrument inlet was previously disconnected, reconnect it now.

SET THE GAS FLOW RATES FOR CHEMICAL ADSORPTION

1. Install a chemical adsorption sample tube with filler rod on the sample port.



Do not touch the quartz sample tube with your fingers. Finger moisture and grease will contaminate the quartz. At high temperatures, the contaminated quartz will disintegrate.

2. Open valves 1 and 9 and allow the sample tube to evacuate for at least 10 minutes to eliminate any outgassing.
3. Backfill the manifold and sample tube with helium.
4. Open the inlet port, CS, 5, 7, 9, and X.
5. Use the regulator pressure control knob to set flow on the internal flow meter to approximately 60 to 80.
6. Close inlet port.

OIL-BASED VACUUM PUMP

Log in to your [customer portal](#) to access the Vacuum Pump Guide.

SERVICE TEST MODE

Options > Service Test Mode

Service Test Mode is a password protected option used to perform certain service tests with the assistance of a trained Micromeritics Service Representative. This password is supplied by your Micromeritics Service Representative.

If a menu item is grayed out, it is usually an indication that Service Test Mode is required.

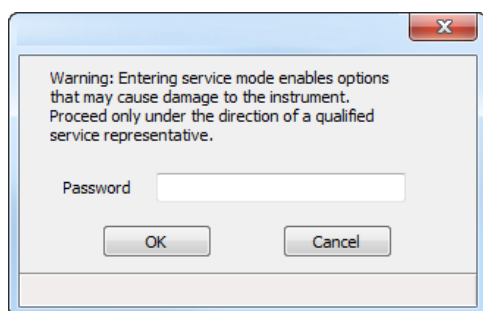

To exit Service Test Mode, go to ***Options > Service Test Mode*** and deselect the *Service Test Mode* option or close the application.

PREVENTIVE MAINTENANCE

Perform the following preventive maintenance procedures to keep the analyzer operating at peak performance. Micromeritics also recommends that preventive maintenance procedures and calibration be performed by a Micromeritics Service Representative every 12 months.

Maintenance Required	Frequency
Clean the analyzer	As required or every 6 months
Lubricate elevator screw	As required or every 6 months. Use a light coat of lithium grease.
Check analysis port dewar	Weekly
Replace sample tube O-ring	As required or every 3 months
Replace port filters	Every 30 days
Replace vacuum pump exhaust filter*	Annually (heavy use may require more frequent maintenance)
Inspect and change vacuum pump fluid*	As required or every 3 months
Replace alumina in oil vapor traps* (if installed)	As required or every 3 months
Replace diaphragm(s) in vacuum pump (oil-free pump only)**	Every 12 months
Clean cold trap tube	As required or every 3 months
Calibrate manifold temperature sensor	Every 12 months
Calibrate system volume	Every 12 months
Check analyzer outgassing rate	Every 6 months
Test analyzer for leaks	As required or every 12 months
Perform reference material analysis	As required or every 3 months
CryoStat	See Preventive Maintenance for the CryoStat on page D - 8

* Oil-based vacuum pumps only.

** After about 12 to 18 months of operation, the diaphragm(s) in the pump will wear out and become completely inoperable. To prevent any instrument downtime due to an inoperable pump, it is recommended that you have the diaphragm(s) replaced by a Micromeritics Service Representative every 12 months.

CHECK AND CLEAN THE DEWAR



When handling dewars, follow the precautions outlined in [Dewar Precautions on page 6 - 1](#).



Always handle glass dewars with care. Any product incorporating a vacuum is a potential safety hazard and should be treated with caution. If in doubt, contact your safety officer.

Ice and suspended frost particles may accumulate in the bottom of the analysis port dewar. Particles or deposits exceeding 1/4 in. in depth may jam between the bottom of the sample tube and the bottom of the dewar, causing the dewar not to raise fully. Accumulations of fine particles impede liquid nitrogen circulation around the bottom of the sample tube. This causes the sample temperature to be slightly higher which, in turn, can cause pore volume measurement errors in those samples exhibiting high isotherm slope above 0.97 relative pressure. Accumulated ice is likely to melt and form a pool of water in the dewar if all liquid nitrogen evaporates. The water must be removed, otherwise it will solidify when liquid nitrogen is added and could press on the bottom of the sample tube causing breakage.

To ensure problems do not develop due to ice accumulation, check the dewar after each use. Clean on a weekly basis.

1. Remove the dewar from the analyzer.
2. Pour out liquid nitrogen into an appropriate cryogenic container. Do not re-use liquid nitrogen.



Do not pour liquid nitrogen directly into a sink. Doing so may cause drain pipes to burst.

3. Rinse the dewar with warm water to melt any remaining ice accumulation which may remain. Dry thoroughly.
4. Replace the dewar.

CLEAN THE ANALYZER

The exterior casing of the analyzer may be cleaned using a clean cloth dampened with isopropyl alcohol (IPA), a mild detergent, or a 3% hydrogen peroxide solution. Do not use any type of abrasive cleaner.



Do not allow liquid to penetrate the casing of the analyzer. Doing so could result in damage to the unit.

- Do not allow liquid to penetrate the casing of the analyzer. Doing so could result in damage to the unit.
- Use only a mild detergent in water to clean safety shields. The use of isopropyl alcohol can damage the shield surface.

CLEAN THE COLD TRAP TUBE

A Cold Trap option is available. Parts and accessories can be found online at www.Micromeritics.com.

Oil vapor from the vacuum pumps accumulates in the cold trap.



If the high vacuum pump is installed, wait for it to completely stop (approximately 10 minutes).

1. Remove the vacuum pump panel.
2. Disconnect the vacuum pump power cord from its power source.
3. Open the instrument schematic.
4. In the sequence of P[n] (port the gas is connected to), PS, 5, 7, and 1, right click each analysis valve and select *Open*. Allow the pressure to stabilize until around atmospheric. Close the valves in the same order as opened. This step fills the analysis vacuum section before disconnecting.
5. Open the degas schematic.
6. Right click degas valve D5 and select *Open*.
7. Right click degas valve D7 and select *Open*.
8. Allow the pressure to stabilize until around atmospheric. Close valve D7 and D5. This step fills the degas vacuum section before disconnecting.
9. Remove the connector nut from the glass tube and inspect the O-ring. Replace the O-ring if it is cracked or worn.

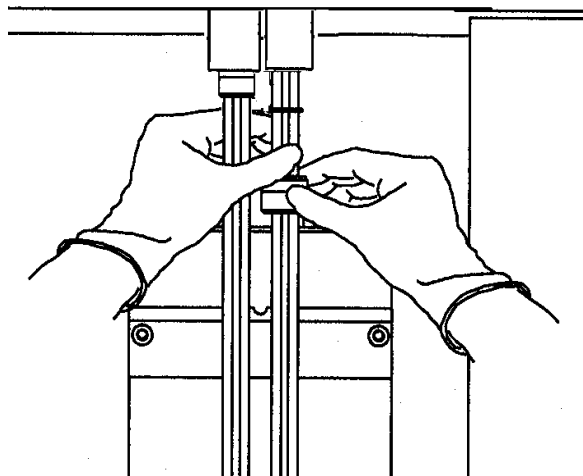

10. Carefully slide the glass tube down over the metal tube and remove the glass tube.
11. Rinse the tube with acetone; then dry the tube.
12. Reinstall the cold trap tube ensuring the O-rings are in place.

13. Repeat the previous steps for the other cold trap.
14. Reconnect the vacuum pump power cord.
15. Replace the vacuum pump access panel.

ENABLE MANUAL CONTROL

Unit [n] > Enable Manual Control



See also:

[Show Instrument Schematic on page 2 - 19](#)

Use to enable the manual control of certain system valves and elevator components on the analyzer schematic. When this option is enabled, a checkmark appears to the left of **Unit [n] > Enable Manual Control**. If the analyzer schematic is not immediately visible, go to **Unit [n] > Show Instrument Schematic**.

LUBRICATE THE ELEVATOR DRIVE ASSEMBLY

The elevator screw is lubricated before it leaves the factory and should not require lubricating. If the elevator starts to vibrate or becomes noisy when traveling, contact a Micromeritics Service Representative for disposition.

PORT FILTERS

Replace Port Filters

A porous metal filter is located in the analysis port and in each degas port. If a filter on a degas port is contaminated, the contaminant may adsorb atmospheric gases when the port is not plugged with either a sample tube or plug, resulting in extended degassing time for samples on that port. Using a contaminated filter on the analysis port may extend the time required to achieve a vacuum at that port and the contaminant may also adsorb or desorb during analysis, affecting the analysis results. A contaminated filter on the analysis port may be detected by a leak test (if the contaminant outgasses) or by a free space reading much lower than normal.

Replace the Analysis Port Filter

A porous metal filter is located in each analysis port. Using a contaminated filter on an analysis port may extend the time required to achieve a vacuum at that port. More importantly, the contaminant may adsorb or desorb during analysis, affecting the analysis results. A contaminated filter on an analysis port may cause a leak test to fail (if the contaminant outgasses) or cause a free space reading to be much lower than normal.



Before replacing a port filter, ensure that the port valve is closed. Observe the analysis system schematic to verify valve status.



To avoid analysis problems, the new filter and O-ring must be clean. Wear gloves when performing this task. Do not touch the parts with bare hands.

1. Remove the dewar and sample tube (or plug).
2. Close the sample valve.
3. Use a wrench to remove the sample tube fitting from the analyzer.

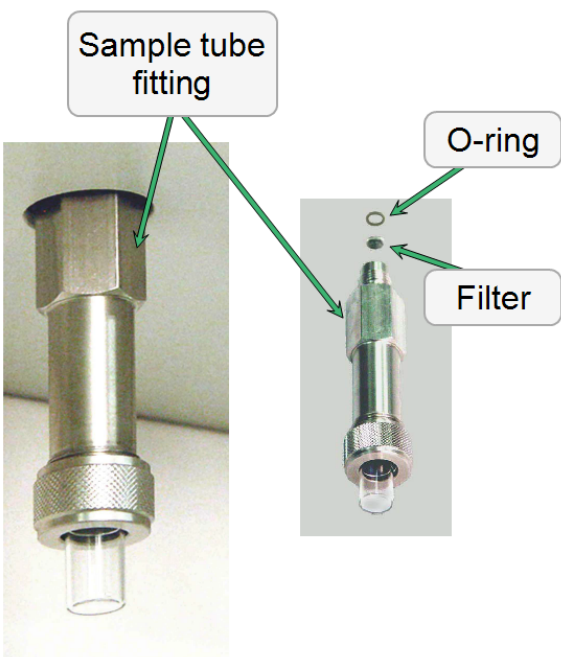

4. Remove and replace the filter and O-ring. If the O-ring and filter are stuck in the port, use a fingernail or plastic instrument to remove them. Using a metal instrument may scratch the sealing surface, causing a leak.
5. Reinstall the analysis port fitting. Securely tighten with a wrench to prevent leaks during evacuation.

Replace Chemical Adsorption Exhaust Port Filter

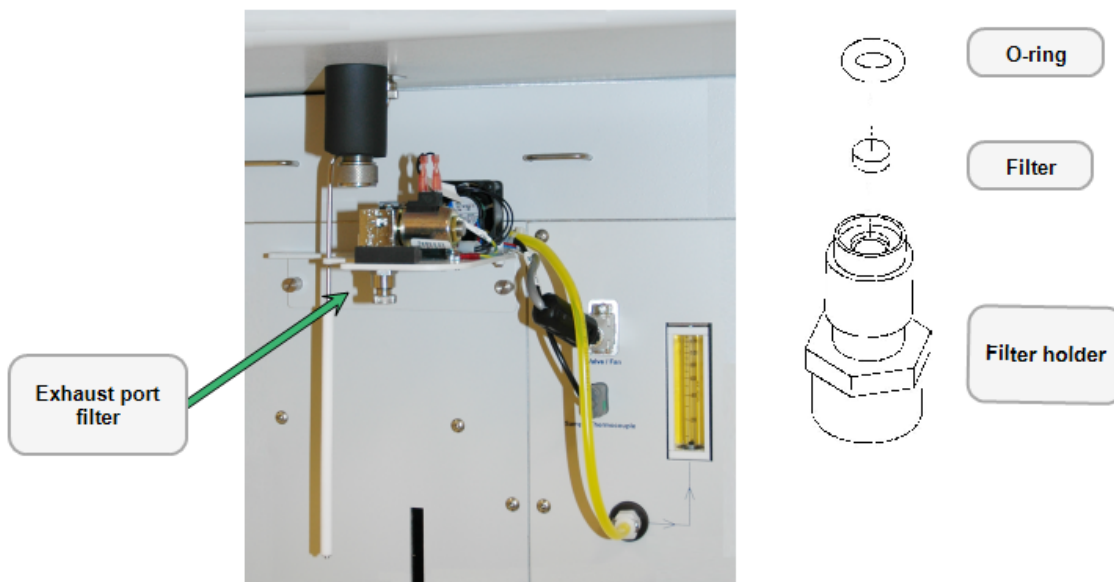

1. Use a 9/16 in. wrench to loosen and remove the filter holder from the exhaust port block
2. Remove the filter and O-ring by pushing them out from the opposite end of the filter holder.
3. Clean the filter holder and filter in acetone or alcohol. If necessary, replace the filter and O-ring.
4. Reassemble the filter, O-ring, and filter holder.
5. Reinstall the assembly in the exhaust port block.

Replace Degas Port Filter



To avoid degassing problems, the new filter and O-ring must be clean. Do not touch them with bare hands.

1. Use a wrench to remove the degas port fitting, filter, and O-ring.
2. Replace the filter and the O-ring.
3. Carefully reassemble the sample tube fitting, filter, O-ring, and manifold connector. Hand tighten, then tighten with a wrench.

REPLACE THE PSAT TUBE O-RING

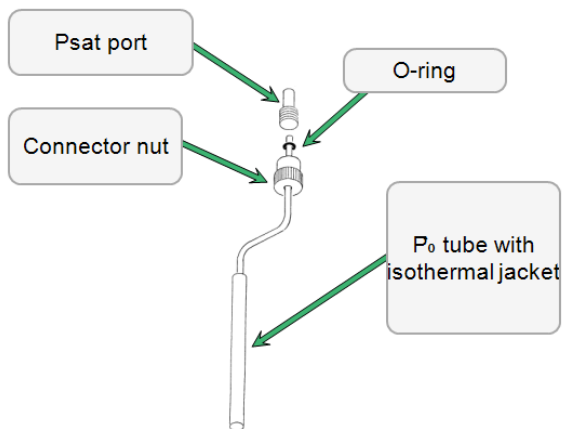

1. Turn the connector nut counter-clockwise to loosen.
2. Pull the connector nut downward.
3. Gently pull the Psat tube downward to remove it from the Psat port.
4. Remove the O-ring from the Psat tube and replace with a new one.
5. Insert the Psat tube into the Psat port.
6. Slide the connector nut up to the Psat port and turn the connector nut clockwise to tighten.

REPLACE THE SAMPLE TUBE O-RING

It is important to maintain a vacuum-tight seal near the top of the sample tube stem. If an O-ring becomes worn or cracked, it does not provide a good seal and will need to be replaced.

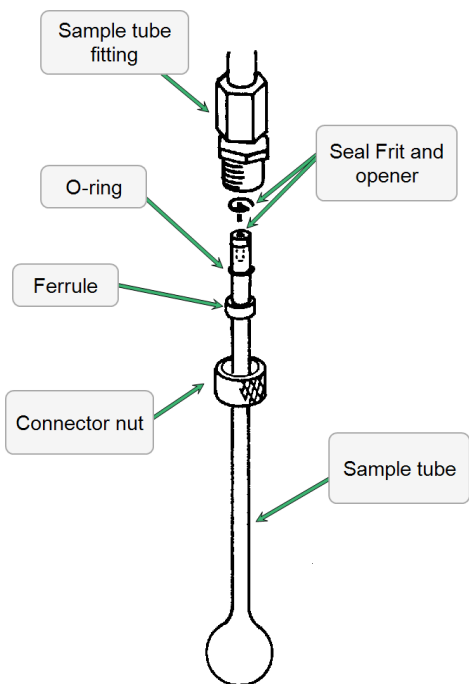

Before removing (or installing) a sample tube, ensure that the port valve is closed. Observe the analyzer schematic to verify valve status.

1. Carefully remove the dewar from the elevator. Take care not to bump the sample tube bulbs with the dewar during this process. Place the dewar aside.
2. Hold the sample tube firmly with one hand and loosen the sample tube connector nut by turning counter-clockwise.



Do not allow the sample tube connector nut to drop onto the sample tube bulb as it may break the tube.

3. Carefully pull the sample tube down until it is free from the port. It may be necessary to grasp the sample tube with both hands.
4. Remove the O-ring from the top of the sample tube and replace it with a new one.

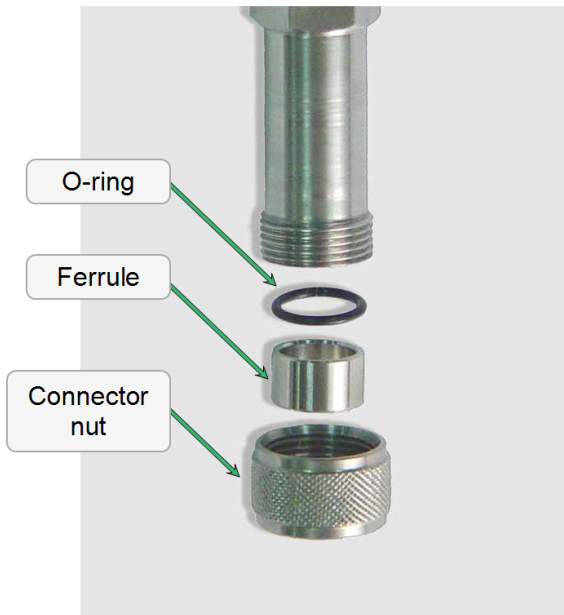

If the O-ring remains inside the sample port, use a pair of tweezers or needle-nose pliers to remove it.

5. While holding the connector nut in place, slide a new O-ring over the sample tube, about 1/4 in. from the top of the tube.

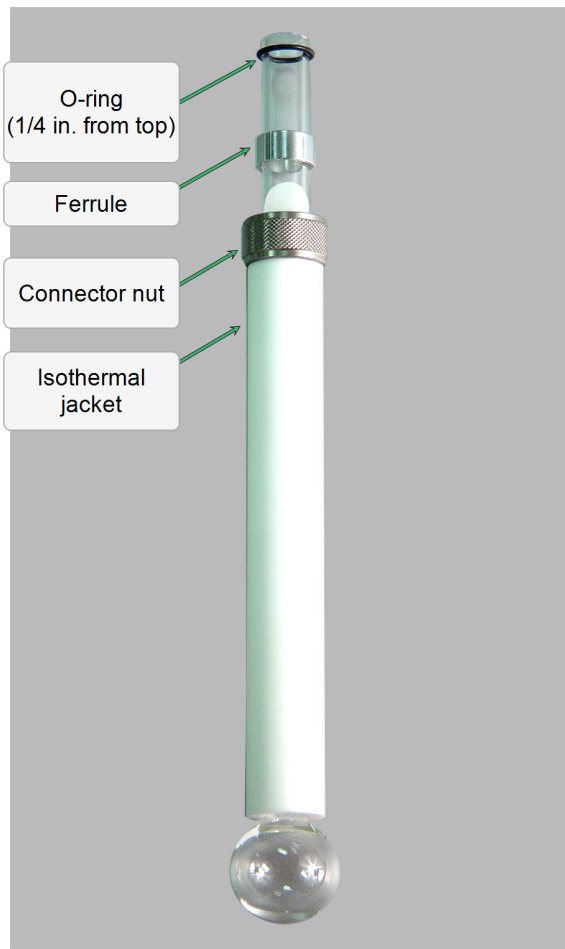

6. After the new O-ring is in place, insert the sample tube back into the sample port until it is fully seated.
7. Slide the sample tube connector nut up the tube until it comes in contact with the port fitting (the ferrule and O-ring will move along with the connector nut). Then, turning clockwise, hand tighten the connector nut to the sample connector.

POWER INSTRUMENT ON AND OFF



DO NOT connect or disconnect cables when the instrument is powered ON.

Power ON the equipment in the following order:

1. Computer, monitor, and printer
2. Analyzer

Power OFF the equipment in the following order:

1. Exit the analysis program. Failure to do so could result in loss of data. If an analysis is in progress when closing the application, the following message is displayed:

2459 - An Instrument is busy. A delay in restarting this application could result in loss of new data. Continue program exit? Yes / No

Yes. Closes the program. The analysis continues and data continue to be collected. The data will be restored when the application is restarted. Reports queued in the print manager will print. If a power failure occurs and an uninterruptible power supply (UPS) is not attached to the analyzer, the data collected after exiting the analysis program are lost.

No. The program remains open and the analysis continues to run.

2. Computer, monitor, and printer
3. Analyzer

RECOVER FROM A POWER FAILURE

The analyzer saves entered and collected data in case of power failure. File parameters and any other data entered will still be present when power is restored. If an analysis was in progress when the power failure occurred, it will be canceled when the analyzer restarts. Any data collected during the analysis will still be present, but the analysis should be restarted in order to produce complete results.

Blank Page

A ATOMIC WEIGHTS AND CROSS SECTIONAL AREAS

Atomic Weights and Cross-sectional Areas for Selected Metals

Metal	Symbol	Atomic Weight (g/mole)	Cross-sectional Area (sq nm)	Density (g/ml)
chromium	Cr	51.996	0.0635	7.19
cobalt	Co	58.933	0.0662	8.9
copper	Cu	63.54	0.0680	8.96
gold	Au	196.967	0.08696	18.9
hafnium	Hf	178.490	0.0862	13.3
iridium	Ir	192.220	0.0769	22.4
iron	Fe	55.847	0.0613	7.89
manganese	Mn	54.938	0.0714	7.43
molybdenum	Mo	95.940	0.0730	10.22
nickel	Ni	58.710	0.0649	8.9
niobium	Nb	92.906	0.0806	8.57
osmium	Os	190.220	0.0629	22.6
palladium	Pd	106.400	0.0787	12.02
platinum	Pt	195.090	0.0800	21.45
rhenium	Re	186.2	0.0649	21.02
rhodium	Rh	102.905	0.0752	12.1
ruthenium	Ru	101.070	0.0613	12.4
silver	Ag	107.868	0.0869	10.5
tantalum	Ta	180.947	0.0800	16.6
thorium	Th	232.038	0.1350	11.7
tin	Sn	118.710	0.1082	4.54
tungsten	W	183.850	0.0741	19.3
vanadium	V	50.942	0.0680	6.11
zirconium	Zr	91.220	0.0877	6.51

Blank Page

B CALCULATE FREE SPACE VALUES FOR MICROPORE ANALYSES

Many microporous materials, such as zeolites and activated carbons, trap and hold helium in their complex pore structures for many hours after being exposed to helium. Helium trapped in micropores can interfere with the analysis at low pressures, causing an “S”-shaped curve at the lower end of the isotherm. For this reason, it is recommended that you enter the warm and cold free space volumes when performing micropore analyses, therefore avoiding exposure of the sample to helium. Two techniques can be used for determining warm and cold free-space values.

The first method is to perform a short analysis on the sample after partial degassing (one pressure point with no incremental dosing), but prior to final sample preparation. Measure the free space during this analysis. The measured free space values will be printed on the report and may then be entered into the sample file after more thorough sample preparation.

The second method requires prior tests using empty tubes that will be employed later for the sample analyses. The measured free space data can be used thereafter on every analysis performed using these sample tubes. This small initial investment of time will save considerable time later. Perform an empty tube analysis on each sample tube you intend to use for micropore analysis. Measure the free space of each sample tube, taking only one pressure point

1. Create a sample tube file from each empty tube test.
2. Use the **Load from Sample File** button to read in the measured free space from the empty tube tests.
3. In the sample file for the sample analysis, pick the appropriate sample tube from the sample tube list.
4. Enter the mass and density of the sample.
5. Choose *Calculate* in the free space options in the analysis conditions.

C CHEMICAL ADSORPTION METHODS

Preparation steps for standard methods of chemical adsorption have been developed over a number of years and are recommended starting points for creating other methods.



For each method, the recommended vacuum set point is 5 mmHg; the recommended temperature increase rate is 10 °C per minute.

- Method 1** * Prepares the sample for carbon monoxide as the analysis gas.
- Method 2** * Prepares the sample for hydrogen as the analysis gas.
- Method 3** Prepares the sample for oxygen as the analysis gas; usually used with silver.
- Method 4** Prepares the sample for hydrogen-oxygen titration.

* Requires repeat analysis

Samples are evacuated to the vacuum set point and evacuation continues for the specified *time*.

- **Flow (soak).** Ramp up to the specified *temperature*, and then continue flowing (soaking) for the specified *time*.
- **Time.** Total time below the vacuum set point that the sample spends at the specified *temperature* or *pressure*.

METHOD 1 - CARBON MONOXIDE ANALYSIS OF PLATINUM

Preparation:

Rate of temperature increase = 10 °C per minute

Vacuum set point = 10 µmHg

Task No.	Action	Ramp Rate (°C / min)	Temperature (°C)	Time (Minutes)
1	Evacuate, helium backfill	10	110	30
2	Flow hydrogen		100	10
3	Flow hydrogen	10	400	30
4	Evacuate, no backfill		400	30
5	Evacuate, no backfill	10	35	60
6	Leak test, outgas rate limit = 10 µmHg/min		35	—
7	Evacuate, no backfill	10	35	20

Analysis:

Requires repeat analysis.

Gas: Carbon monoxide

Temperature: 35 °C

Heat rate: N/A

Equilibration interval: 10 sec

Relative target tolerance: 5.0%

Absolute target tolerance: 5.0 mmHg

Repeat analysis: Yes

Fast evacuation: No

Unrestricted evac pressure: 30 mmHg

Evacuation time: 30 min

Free space:	Measure
Incremental dosing:	No
Line fit:	Enabled for all pressure points
Pressure table (mmHg):	200, 250, 300, 350, and 400

METHOD 2 - HYDROGEN ANALYSIS

PLATINUM

Preparation:

Rate of temperature increase = 10 °C per minute

Vacuum set point = 10 µmHg

Task No.	Action	Ramp Rate (°C / min)	Temperature (°C)	Time (Minutes)
1	Flow helium	10	200	10
2	Evacuate, no backfill		100	10
3	Flow hydrogen	10	400	30
4	Evacuate, no backfill		400	30
5	Evacuate, no backfill	10	35	60
6	Leak test, outgas rate limit = 10 µmHg/min		35	—
7	Evacuate, no backfill	10	35	10

Analysis:

Requires repeat analysis.

Gas: Hydrogen

Temperature: 35 °C

Heat rate: N/A

Equilibration interval: 10 sec

Relative target tolerance: 5.0%

Absolute target tolerance: 5.0 mmHg

Repeat analysis: Yes

Fast evacuation: No

Unrestricted evac pressure: 30 mmHg
 Evacuation time: 30 min (experience may indicate the need for a longer evac time)

Free space: Measure
 Incremental dosing: No
 Line fit: Enabled for all pressure points
 Pressure table (mmHg): 200, 250, 300, 350, and 400

PALADIUM

Preparation:

Rate of temperature increase = 10 °C per minute
 Vacuum set point = 10 µmHg

Task No.	Action	Ramp Rate (°C / min)	Temperature (°C)	Time (Minutes)
1	Evacuate	10	100	30
2	Flow oxygen		100	5
3	Flow oxygen	10	350	30
4	Evacuate		350	15
5	Evacuate	10	100	15
6	Flow hydrogen		100	5
7	Flow hydrogen	10	350	120
8	Evacuate		350	30
9	Evacuate	10	35	30
10	Analysis		35	

Analysis:

Gas:	Hydrogen
Temperature:	100 °C
Heat rate:	N/A
Equilibration interval:	10 sec
Relative target tolerance:	5.0%
Absolute target tolerance:	5.0 mmHg
Repeat analysis:	Yes
Fast evacuation:	No
Unrestricted evac pressure:	30 mmHg
Evacuation time:	30 min
Free space:	Measure
Incremental dosing:	No
Line fit:	Enabled for all pressure points
Pressure table (mmHg):	120, 155, 190, 225, and 260

NICKEL

Preparation:

Rate of temperature increase = 10 °C per minute

Vacuum set point = 10 µmHg

Task No.	Action	Ramp Rate (°C / min)	Temperature (°C)	Time (Minutes)
1	Evacuate	10	100	30
2	Evacuate	10	450	5
3	Flow oxygen		450	120
4	Evacuate		450	30
5	Evacuate	10	35	30
6	Analysis		35	

Analysis:

Gas: Hydrogen

Temperature: 35 °C

Heat rate: N/A

Equilibration interval: 10 sec

Relative target tolerance: 5.0%

Absolute target tolerance: 5.0 mmHg

Repeat analysis: Yes

Fast evacuation: No

Unrestricted evac pressure: 30 mmHg

Evacuation time: 30 min

Free space: Measure

Incremental dosing: No

Line fit: Enabled for all pressure points
Pressure table (mmHg): 100, 150, 200, 250, and 300

METHOD 3 - OXYGEN ANALYSIS OF SILVER

Preparation:

Rate of temperature increase = 10 °C per minute

Vacuum set point = 10 µmHg

Task No.	Action	Temperature (°C)	Time * (Minutes)
1	Evacuate	100	30
2	Flow oxygen	100	10
3	Ramp temperature while flowing oxygen	170	10 °C / min
4	Hold temperature while flowing oxygen	170	60
5	Evacuate	170	30
6	Flow hydrogen	170	60
7	Evacuate temperature < 10 mmHg	170	30
8	Analysis	170	

***Time for evacuation is the number of minutes below set point at the specified temperature. Time for gas flow is the number of minutes at the specified temperature.**

Analysis:

Gas: Oxygen

Temperature: 170 °C

Line fit: Enabled for all pressure points

Repeat analysis: No

Pressure table (mmHg): 40, 67, 93, and 120

METHOD 4 - HYDROGEN-OXYGEN TITRATION**PLATINUM****Preparation:**

Rate of temperature increase = 10 °C per minute

Vacuum set point = 10 µmHg

Analysis:

Gas: Hydrogen

Temperature: 35 °C

Heat rate: N/A

Equilibration interval: 10 sec

Relative target tolerance: 5.0%

Absolute target tolerance: 5.0 mmHg

Repeat analysis: No

Fast evacuation: No

Unrestricted evac pressure: 30 mmHg

Evacuation time: 30 min

Free space: Measure

Incremental dosing: No

Line fit: Enabled for all pressure points

Pressure table (mmHg): 75, 110, 240, 170, and 200

PALLADIUM

Preparation:

Rate of temperature increase = 10 °C per minute

Vacuum set point = 10 µmHg

Task No.	Action	Ramp Rate (°C / min)	Temperature (°C)	Time (Minutes)
1	Flow helium	10	200	10
2	Evacuate, no backfill		100	10
3	Flow hydrogen	10	400	30
4	Evacuate, no backfill		400	30
5	Evacuate, no backfill	10	35	30
6	Leak test, outgas rate limit = 10 µmHg/min		35	—
7	Evacuate, no backfill	10	35	10
8	Flow hydrogen		35	10
9	Evacuate, no backfill	10	35	10
10	* Flow Air		35	2
11	Evacuate, no backfill		35	10

* Use clean, dry air or 2%, 5%, or 10% O₂ in helium or argon.

Analysis:

Gas:	Hydrogen
Temperature:	35 °C
Heat rate:	N/A
Equilibration interval:	10 sec
Relative target tolerance:	5.0%
Absolute target tolerance:	5.0 mmHg
Repeat analysis:	No
Fast evacuation:	No
Unrestricted evac pressure:	30 mmHg
Evacuation time:	30 min
Free space:	Measure
Incremental dosing:	No
Line fit:	Enabled for all pressure points
Pressure table (mmHg):	120, 155, 190, 225, and 260

Blank Page

D CRYOSTAT

A CryoStat is an available option. Parts and accessories can be found online at www.Micromeritics.com.

Unit [n] > Enable CryoStat

CRYOSTAT OPERATING INSTRUCTIONS

The cryostat provides automatic analysis temperature control over a wide range of sub-ambient temperatures.



- Read and fully understand this entire section prior to carrying out operations on the system.
- All system components must be powered ON in the sequence provided in this section.
- Pay attention to all local safety systems and requirements and consider the specifics of the experiment when operating the system.

1. Prior to starting any analysis on the system, ensure the following:
 - Go to **Unit [n] > Enable CryoStat** and ensure a checkmark displays to the left of the menu option. A checkmark indicates the item has been selected and disables the elevator during an analysis when using the cryostat.
 - The cryostat is correctly mounted and held firmly in place by the metal retaining bands.
 - Release the brake on the cryostat cradle and move the system upwards to check that the sample well and the analyzer sample port is correctly aligned.
 - Check that the vacuum connection, helium connection, and wired connections to the compressor and temperature controller are in place and correctly fitted.
2. Prepare the samples:
 - Samples can be prepared in-situ using the analyzer heating mantle (if the heating mantle fits with the cryostat installed). This will depend on the type of heating mantle used.
 - The cryostat can be prepared to run analyses in the DOWN position while the samples are being prepared. Leave the insulating cover for the cryostat sample well in place while doing this.
3. Turn on the helium supply and adjust the rotameter to scale position 55. This corresponds to a flow rate of approximately 5 ml/min. See [Rotameter Scale Readings on page D - 3](#).
4. Allow the helium to purge the sample well for fifteen minutes. This purge procedure removes water vapor from the sample well and prevents water vapor from freezing when the system is in use at sub-ambient / cryogenic temperatures.
5. Open the degas port 2 valve to the cryostat to ensure a good vacuum inside the cryostat vacuum jacket.

6. Power ON the compressor — first switch the circuit breaker to the UP position and then power ON the analyzer. The compressor will now start to pump.
7. Press the **ALL OFF** button to power ON the temperature controller. Set the required temperature on the temperature controller or in the analysis application. If using the temperature controller, refer to the temperature controller manual supplied by the manufacturer.
8. Create a sample file (see [Create Sample Files on page 3 - 2](#)). There are settings specific to physical adsorption analyses using a cryostat in [Analysis Conditions on page 4 - 5](#).
9. With the sample tube in place, preparation completed, and the tube cooled to ambient temperature, slide the insulating cover up so that the cover fits snug against the mouth of the raised cryostat.
10. When prompted by the analyzer application, raise the cryostat.
11. Allow the sample to thermally equilibrate before starting the analysis.
12. When prompted by the analyzer application, lower the cryostat.
13. If the sample tube is to be removed, go to **Unit [n]> Enable Manual Control** and pressurize the sample tube to 760 mmHg at ambient temperature. See [Enable Manual Control on page 12 - 13](#).
14. Weigh the sample after analysis and enter the sample weight into the sample file. See [Determine the Sample Mass on page 6 - 8](#).
15. The cryostat can now be used to analyze another sample at the same temperature or change the set point temperature. It is recommended that the cryostat remained powered ON unless left unused for a long period of time. If it is necessary to power OFF the cryostat, set it to ambient temperature and allow it to come up to room temperature.

INSTALL SAMPLE TUBE FOR THE CRYOSTAT



See:

[Sample Tube Installation on page 6 - 16](#)

Sample tubes for the cryostat are installed in the same manner as the sample tubes for the analyzer.

ROTAMETER SCALE READINGS

The rotameter scale corresponds approximately to flow rates:

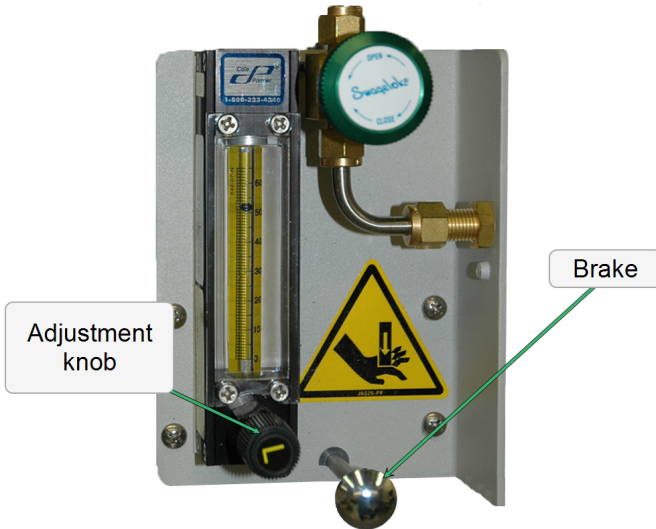

Rotameter Scale to Flow Rate

Scale Reading	Flow Rate (ml/min)
65	5.8
55	5
45	4.3
35	3.3
25	2.5
15	1.8
5	1.3

REMOVE THE CRYOSTAT FROM THE ANALYZER

To run a normal analysis, the cryostat must be removed.

1. Move the cryostat to the DOWN position.
2. Place the brake in the bottom position.
3. Remove the 1/8 in. nylon helium tube.
4. Close degas port 2 valve.
5. Remove the 1/4 in. flexible stainless steel evacuation hose at the degas port.
6. Remove the large hose clamps and lift the entire cryostat off the cradle.
7. Lay the assembly on an adjacent bench so that other hoses do not need to be disconnected.
8. Close the helium purge supply, power OFF the compressor, and turn OFF the temperature controller.



It is not necessary to remove the carriage assembly from the analyzer, however, the special safety shield (supplied with the cryostat kit) should be used. This shield has been modified to reach over the cryostat panel and hook onto the analyzer.

TROUBLESHOOTING THE CRYOSTAT

Frost or ice accumulates around the outside of the cryostat in the area of the sample well

Cause: The internal vacuum is degrading and must be re-evacuated.

Action: Effective re-evacuation can be done only when the cryostat is warm, such as after an analysis. It is recommended that the vacuum pump always remain powered ON.

Elevator tries to rise

Cause: Analysis program is not set to enable the cryostat.

Action: In the analysis program, go to **Unit [n] > Enable CryoStat** and ensure that this option is selected. Failure to do so will cause the P₀ port to be evacuated and the elevator will try to rise.

Valve motor in cryostat cold head does not start when the compressor starts

Cause A: Cold head cable is not connected.

Action A: Stop the compressor. Connect the cable.

Cause B: Open circuit in the cold head cable.

Action B: Disconnect the cold head cable. Check each conductor for continuity. Replace the cable if necessary.

Cause C: Defective valve motor.

Action C: Contact your Micromeritics Service Representative.

Cause D: Blown fuse in the compressor's electrical box.

Action D: See the manual supplied by the compressor manufacturer.

Valve motor in cryostat cold head hums but does not start

Cause A: Valve disk has stalled.

Action A: Check the operating pressures on the compressor. Contact your Micromeritics Service Representative.

Cause B: Defective valve motor.

Action B: Contact your Micromeritics Service Representative.

Cause C: Open circuit in the cold head cable.

Action C: Disconnect the cold head cable. Check each conductor for continuity. Replace the cable if necessary.

Valve motor on the cryostat cold head runs but there is no cooldown

Cause A: No insulating vacuum.

Action A: Check the vacuum system for operation and leaks.

Cause B: Gas line couplings are not fully engaged.

Action B: Ensure all couplings are fully engaged and torqued.

Cause C: Gas lines are connected incorrectly.

Action C: Reconnect the gas lines. See the manual supplied by the compressor manufacturer.

Cause D: Compressor output is inadequate.

Action D: Troubleshoot the compressor. See the manual supplied by the compressor manufacturer.

Shroud is sweating or abnormally cold

Cause: Loss of insulating vacuum.

Action: Check the vacuum system for operation and leaks.

Abnormally noisy operation after a sustained period of five to fifteen minutes

Cause A: Incorrect compressor pressures.

Action A: Troubleshoot the compressor. See the manual supplied by the compressor manufacturer.

Cause B: Contaminants in the gas.

Action B: Perform *Gas Cleanup and Recharging* procedure on the cold head, compressor, and the gas lines. See the manual supplied by the compressor manufacturer. Contact your Micromeritics Service Representative.

Intermittent operation

Cause: Compressor is cycling on and off.

Action: Troubleshoot the compressor. See the manual supplied by the compressor manufacturer.

Temperature is cycling

Cause: Contaminated gas is causing a cold head freezing-thawing cycle.

Action: Perform *Gas Cleanup and Recharging* procedure on the cold head, compressor, and the gas lines. See the manual supplied by the compressor manufacturer. Contact your Micromeritics Service Representative.

Sudden loss of refrigeration capacity

Cause A: Loss of insulating vacuum.

Action A: Check the vacuum system for operation and leaks.

Cause B: Compressor malfunction.

Action B: Troubleshoot the compressor. See the manual supplied by the compressor manufacturer.

Slow loss of refrigeration capacity

Cause A: Small insulating vacuum leak.

Action A: Leak check and repair the vacuum system.

Cause B: Worn seals in the cold head.

Action B: Contact your Micromeritics Service Representative.

Cause C: Cold head is leaking.

Action C: Contact your Micromeritics Service Representative.

PREVENTIVE MAINTENANCE FOR THE CRYOSTAT

The preventive maintenance procedures can be located in the documents supplied by the cryostat manufacturer.

Maintenance Required	Frequency
Cold head	Every 13,000 hours
Compressor (absorber)	Every 30,000 hours

CRYOSTAT CALIBRATION

The cryostat temperature reading does not necessarily reflect the temperature at the sample. The discrepancy is large enough to cause significant differences between data taken with a cryogenic bath and data taken with the cryostat set to the temperature of the bath.

One solution is to modify the voltage-to-temperature curve stored in the temperature controller so that the reading accurately reflects the temperature of the sample. This option requires additional interaction with the temperature controller to download, upload, and select the voltage-to-temperature curves. However, this is straightforward with the Lakeshore controller and their Curve Handler software.

REQUIRED ITEMS

- An ASAP 2020 analyzer equipped with an installed Micromeritics cryostat unit.
- A selection of adsorptives to cover the temperature range to be calibrated — such as nitrogen, argon, methane, ethane, and propane. Choose adsorptives whose saturation pressure is less than 800 mmHg at the measurement temperatures.
- The Lakeshore Curve Handler software (free download): <http://www.lakeshore.com/products/Pages/curvehandler.aspx>.
- An empty sample tube for the Micromeritics gas adsorption analyzer being used.
- A spreadsheet application — such as Microsoft Excel. Knowledge of how to load a .TXT file containing tabular data into a spreadsheet application is beneficial.

CALIBRATION PROCEDURE

1. Go to **Unit [n] > Show Instrument Schematic** and lower the elevator.
2. Go to the **Unit [n]** menu. Ensure there is no checkmark to the left of **Enable CryoStat**.
3. Install a blank sample tube into the gas adsorption analyzer.
4. Raise the cryostat and lock it in place following the general cryostat procedure.
5. Set the cryostat to the required temperature. On the LakeShore temperature controller, press **SETPOINT**, enter the temperature (in kelvin), then press **ENTER**.

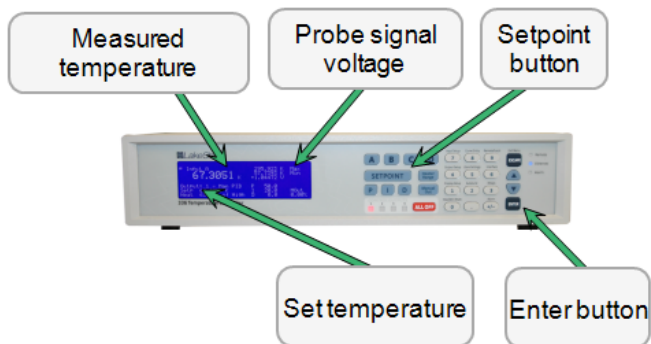

6. Wait until the cryostat reaches the entered temperature. The time varies depending on how big the temperature jump is. For example, going from 200 K to 215 K may take 15 to 20 minutes; going from 298 K to 77 K might take 90 minutes. Once the cryostat has reached the operating temperature, record the set temperature, the measured temperature, and the cryostat signal probe voltage.
7. Create a sample file to measure saturation pressure.

In Analysis Conditions:

- a. Select the adsorptive to be used.
- b. Select the *Absolute pressure dosing* option.
- c. Enter the pressure settings shown in the *Pressure Settings for ASAP 2020* table below.
- d. Click **Dosing** and enter the dosing settings in the *Dosing Options for ASAP 2020* table shown below. Click **OK** to return to the Analysis Conditions window.
- e. Click **Equilibration**. In the table, enter an absolute pressure of 1,000.00000 and equilibration interval of 5. Click **OK**.

Pressure Settings for ASAP 2020

	Starting Pressure (mmHg)	Pressure Increment (mmHg)	Ending Pressure (mmHg)
Line 1	0.000000		100.000000
Line 2	100.000000		980.000000

Dosing Options Settings for ASAP 2020

Field	Enter...
Absolute pressure Tolerance	5.000 mmHg
Relative pressure tolerance	5.0 %
Low Pressure incremental dose mode	Select this option
Dose amount	20.0000 cm ³ /g STP
Equilibration Delay	Minimum. 0.00 h Maximum. 999.00 h
Maximum number of decants	6

- Once the analyzer is set up and the temperature for the first data point has reached equilibrium, start the analysis defined by the sample file. The analyzer will dose the sample tube with 20 cm³/g STP of adsorptive. Once the tube pressure reaches the adsorptive saturation pressure, the generated isotherm will climb straight up. Take several points at this saturation pressure, then pause the analysis and set the cryostat to the next temperature.

Once the cryostat has reached the set temperature and has equilibrated a few minutes, record the cryostat temperature and the probe signal, then resume the analysis. Perform this cycle for the number of temperature points required for the adsorptive being used. Typical isotherms are shown below. Note that the temperature labels are for clarity and are not a part of the normal report.

Additional adsorptives will allow the calibration to be extended. A set of local fits may be needed to cover a wide temperature change.



Depending on the selected adsorptive, a warning message may be given indicating that 950 mmHg is not the saturation pressure for the temperature being used. This is a normal message and will not interfere with the experiment. Click **OK** and continue with the analysis.



These analyses will not end and will have to be terminated manually by stopping the analysis window. To terminate the analysis, click **Cancel**, then wait a few seconds and click **Cancel** again (do not double-click the **Cancel** button).

The analysis will end abruptly with adsorptive in the sample tube. The sample tube must be manually evacuated before the cryostat is lowered.

Manually close all valves. Open valves 2, 7, and 9 in that order. Once the pressure in the sample tube is less than 300 mmHg, open valve 1.

The cryostat can be lowered once the sample tube has been completely evacuated.

This saturation pressure data can either be read from the graph or an isotherm report can be made and the saturation pressure read from the report:

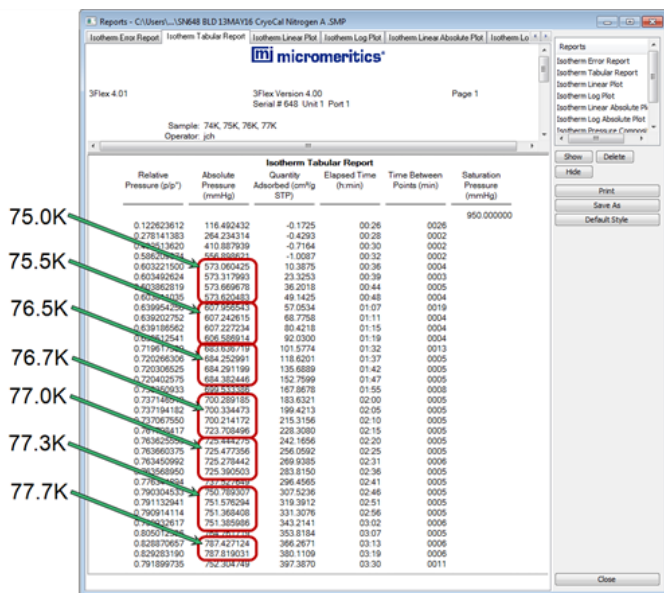

9. Place the data in table format using a spreadsheet application such as Microsoft Excel.

Temperature and Saturation Pressure Values

	Set Temperature (K)	CryoStat Temperature (K)	Signal Probe Voltage	Measured Saturation Pressure (mmHg)	Sample Tube Temperature (K)
Nitrogen	65	64.999	1.04878	137.833	65.317
	67.5	67.498	1.04474	206.334	67.778
	70	69.999	1.04066	301.792	70.294
	73	72.996	1.03572	454.217	73.239
	73	72.996	1.03572	456.148	73.271
	73	72.998	1.03571	452.139	73.239
	75	75.002	1.03240	584.063	75.189
	75	75.002	1.03245	587.793	75.240
	77	76.993	1.02896	743.094	77.165
	77	76.995	1.02897	742.343	77.156
Ethylene	78	78.002	1.02737	832.533	78.165
	140	139.999	0.91437	111.175	142.470
	145	144.999	0.90456	168.125	147.470
	150	150.000	0.89477	245.617	152.350

Set Temp	Cryostat temperature setting, in kelvin.
CryoStat Temperature	Temperature reported by the temperature controller.
Signal Probe Voltage	Signal probe voltage reading.
Measured Saturation Pressure	Equilibrium pressure measured by the instrument when the isotherm is vertical.
Sample Tube Temperature	Sample tube temperature calculated from the measure saturation pressure using NIST's REFPROP program (bundled with the Micromeritics applications).

	Temperature (K)	Pressure (mmHg)	Liquid Density (kg/m ³)	Vapor Density (kg/m ³)	Liquid Enthalpy (kJ/kg)	Vapor Enthalpy (kJ/kg)	Liquid Entropy (kJ/kg-K)	Vapor Entropy (kJ/kg-K)
1	75.037	573.00	816.51	3.5555	-126.76	75.345	2.7724	5.4658
2	75.497	607.00	814.45	3.7492	-125.82	75.713	2.7848	5.4542
3	76.472	684.00	810.08	4.1852	-123.83	76.479	2.8108	5.4302
4	76.664	700.00	809.21	4.2753	-123.43	76.628	2.8159	5.4255
5	76.957	725.00	807.89	4.4159	-122.83	76.854	2.8237	5.4185
6	77.254	751.00	806.54	4.5617	-122.23	77.081	2.8315	5.4114
7	77.663	788.00	804.68	4.7687	-121.39	77.391	2.8423	5.4017
8								

Screenshot from REFPROP software

The spreadsheet data can be graphed in the REFPROP spreadsheet program. Plot the REPROP to determine temperature versus the Cryostat reading. Fit the data points:

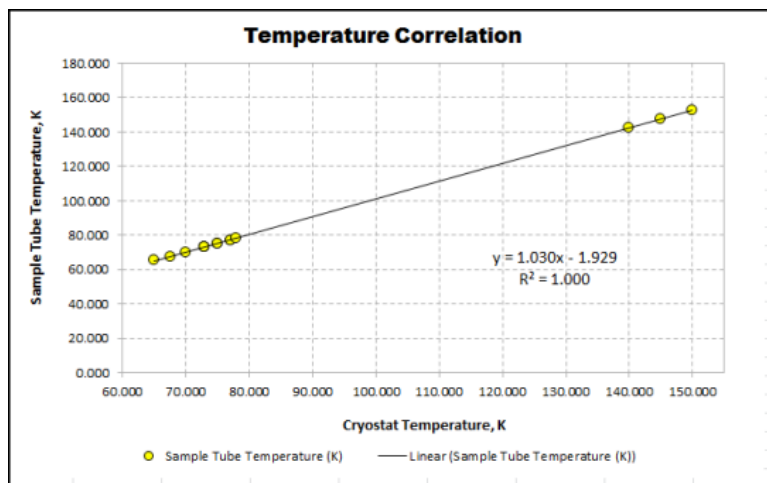

Additional adsorptives will allow the calibration to be extended. The following graph contains data for nitrogen combined with data from ethane:

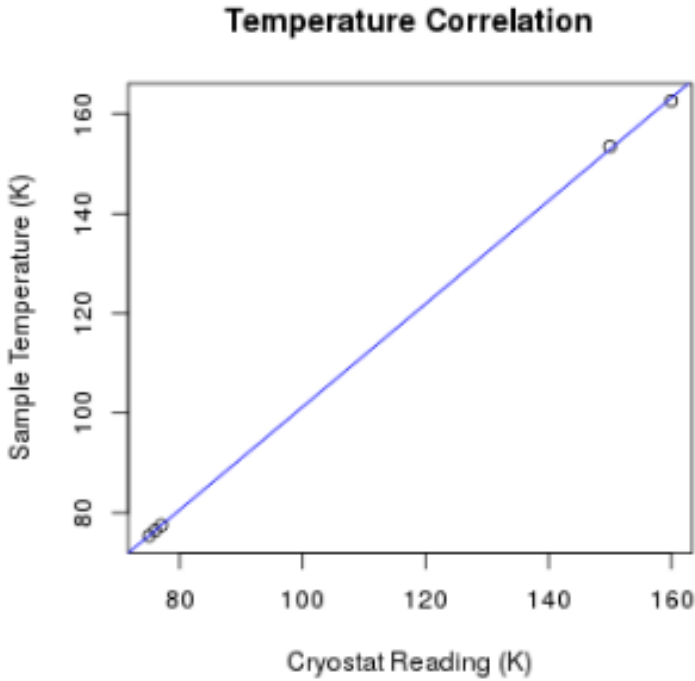

10. The REPROP determined sample tube temperatures, combined with the signal probe voltages read from the LakeShore controller are then used to construct a cryostat calibration curve.

The LakeShore Curve Handler program (shown below) is used for this operation. (See the LakeShore Curve Handler manual for communications information.) Connect the cryostat to the computer via an Ethernet connection.

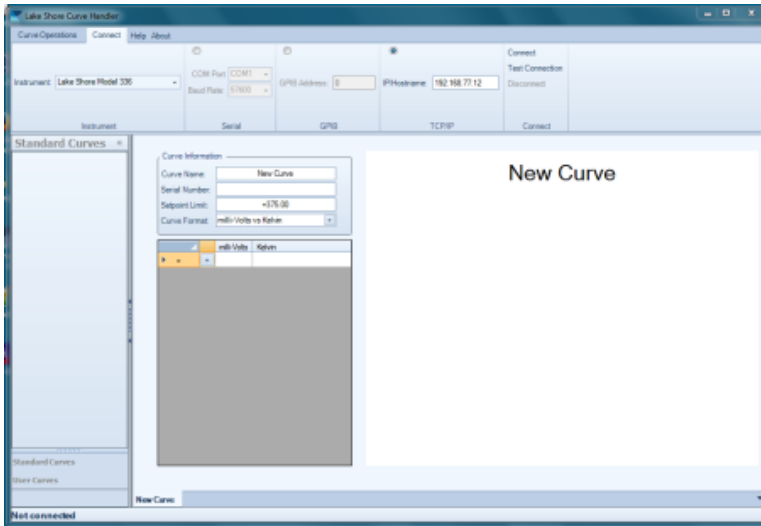

- Click **Connect** to establish communication with the LakeShore Temperature Controller. Once communication is established, all the calibration curves in the LakeShore Temperature Controller will be listed.

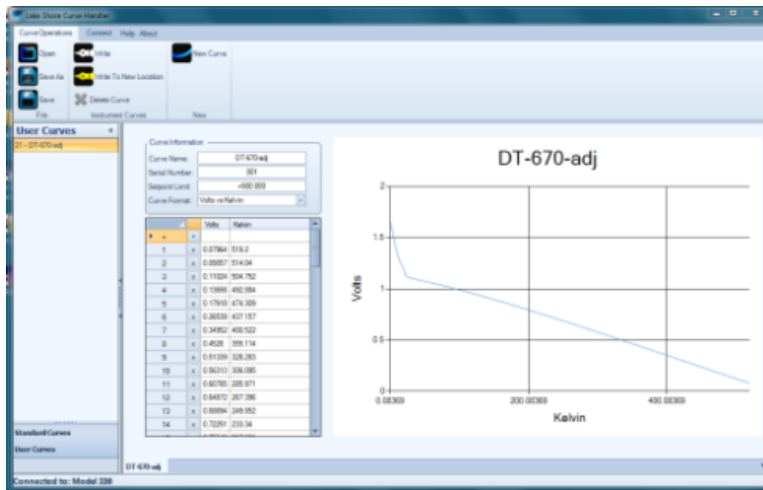

- The ColdEdge Cryostat/LakeShore Model 336 Temperature Controller uses the DT-670 silicon diode as the temperature sensor according to ColdEdge Micromeritics Interface Owner's Manual. Select the curve for the DT-670 temperature probe. Click **Save As** and save the DT-670 curve with a different name (i.e., *DT-670-xx*). Note that all calibration curves are stored as ASCII files in the Documents library with the file extension *.curve*. There will be a *DT-670.curve* file and a *DT-670-xx.curve* file.

```

Sensor Model: DT-670
Serial Number: STANDARD
Data Format: 2 (volts/kelvin)
SetPoint Limit: +500.000

Measurement (volts)    Temp (K)
7.964000E-02          5.050000E+02
9.057000E-02          5.000000E+02
1.102400E-01          4.910000E+02
1.365600E-01          4.795000E+02
1.791800E-01          4.615000E+02
2.653900E-01          4.255000E+02
3.495200E-01          3.900000E+02
4.528000E-01          3.460000E+02
5.133900E-01          3.200000E+02
5.631300E-01          2.985000E+02
6.078500E-01          2.790000E+02
6.487200E-01          2.610000E+02
6.869400E-01          2.440000E+02
7.225100E-01          2.280000E+02
7.554900E-01          2.130000E+02
7.869900E-01          1.985000E+02
8.170200E-01          1.845000E+02
8.445400E-01          1.715000E+02
8.695800E-01          1.595000E+02
8.932300E-01          1.480000E+02
9.144700E-01          1.375000E+02
9.343600E-01          1.275000E+02
9.529000E-01          1.180000E+02
9.701300E-01          1.090000E+02
9.860700E-01          1.005000E+02
9.989200E-01          9.350000E+01
1.010640E+00          8.700000E+01
1.021250E+00          8.100000E+01
1.031670E+00          7.500000E+01
1.041890E+00          6.900000E+01
1.051920E+00          6.300000E+01
1.062770E+00          5.640000E+01
1.074720E+00          4.900000E+01
1.091100E+00          3.870000E+01
1.096020E+00          3.570000E+01
1.100140E+00          3.330000E+01
1.103930E+00          3.120000E+01

```

13. The LakeShore Curve Handler instruction manual provides several methods of entering user created calibration. The following process uses a file copy of a modified version of the DT-670 curve previously saved.
14. Produce a modified calibration curve by applying the fit from step 8 to the temperatures in DT-760 curve.
15. Start the LakeShore Curve Handler program and establish communication with the LakeShore Temperature Controller.

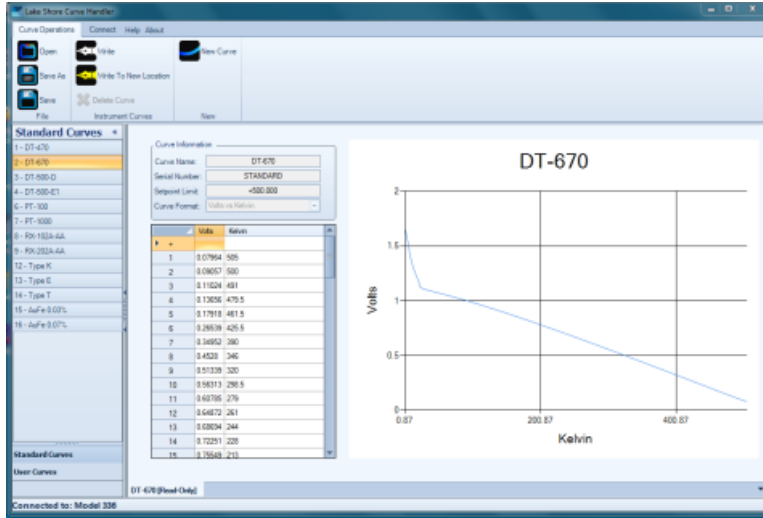

16. Click **Open** and select the modified *DT-670-xx.curve*. Place this curve in the first empty bin. User curve bins start at Number 21.
17. The new curve should now be able to be loaded into the LakeShore Curve Handler program. Click the *User's Curve* tab in the lower left side of the window.

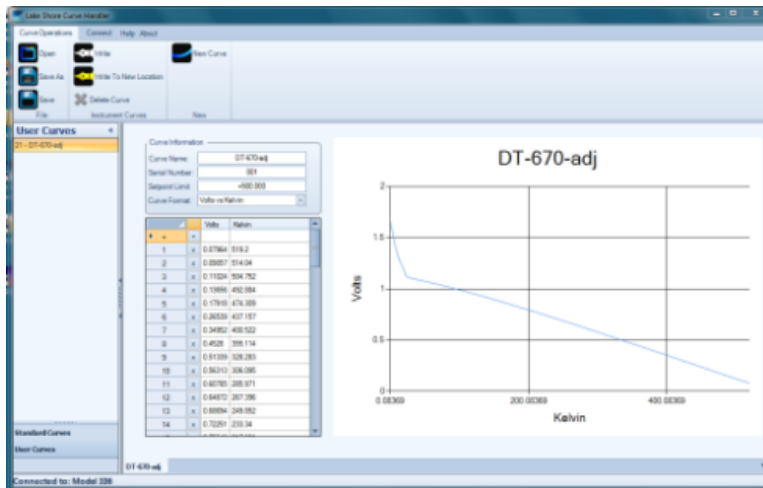

18. Note in this example the modified curve *DT-670-xx.curve* is in bin 22 (left column) and the curve is displayed on the right. The values should be reviewed and any changes made. Click **Save** if changes have been made. Click **Write** to load the new curve into the LakeShore Temperature Controller. Exit the LakeShore program.
19. To select the new curve, on the temperature controller, press the *Input* command (key 7), select the *Input* channel (usually *A*), use the arrows to navigate to the curve menu, press **Enter**, then select the curve. Use curve 22 in this example. Press **Enter** once more, then press **Escape**. The new, modified curve is now in place. More details can be found on page 52 of the LakeShore Model 336 Temperature Controller User's Manual.

The table below shows the effect of the new curve:

Temperature and Saturation Pressure Values

Set Temp (K)	Cryostat Temperature (K)	Measured Saturation Pressure (mmHg)	Uncalibrated Sample Tube Temperature (K)	Calibrated Sample Tube Temperature (K)	% Error (Calculated vs Uncalibrated)
73	72.997	473.450	73.553	73.250	-0.414
75	74.996	615.020	75.603	75.215	-0.517
77.3	77.002	786.618	77.648	77.029	-0.804

E DATA LOGGING

The ASAP 2020 has the added capability to collect, access, and use real time transient data (pressures, temperatures, quantities adsorbed, etc.) during adsorption and desorption measurements. Data are collected every half second. Data logging can also be performed from a Smart VacPrep degasser attached to the analyzer. Log in to your [customer portal](#) to access

This document provides :

- installation instructions for the PuTTY client and outlines how to access and use the data file, and
- installation instructions for Python components and outlines how the captured data can be handled using Python scripts.

INSTALL THE PUTTY CLIENT

PuTTY is an open source SSH and telnet client that can be used to access the transient data output by the analyzer. No additional Micromeritics application is required. The PuTTY .exe file runs directly from a desktop shortcut. Download the PuTTY application using the following URL (only save the *putty.exe* file):

<http://www.chiark.greenend.org.uk/~sgtatham/putty/download.html>

To connect to the analyzer:

1. In the ASAP 2020 application, go to **Unit [n] > Unit Configuration** and make a note of the analyzer IP address.

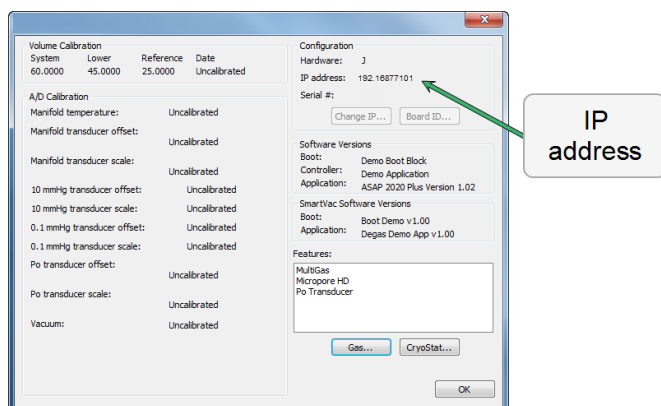

2. In the *PuTTY Configuration* window:
 - a. Enter the analyzer IP address (from Step 1) into the PuTTY application.
 - b. Enter *54000* in the *Port* field.
 - c. Select *Raw* as the connection type.

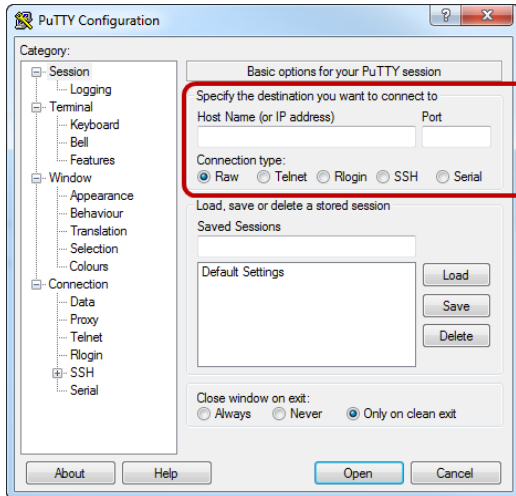

3. To save the settings (optional):

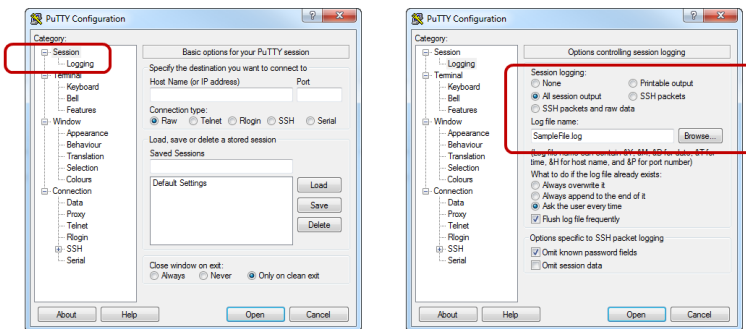

- a. In the **Category** box, select **Session > Logging**.
- b. In the **Session logging** group box, select **All session output**.
- c. In the **Log file name** group box, click **Browse** to select the destination and enter a .txt file name. It may be helpful to name this file the same as the sample file to be analyzed.

4. Click **Open** to start collecting the data.



The PuTTY application can be started before the ASAP 2020 analyzer starts collecting data — it will be *waiting* until data output from the analyzer begins.

ACCESS THE DATA LOG FILE

The text file created in the previous section (Step 3c) contains the transient data and can be accessed using any means that accepts tab separated values — such as: Notepad, Microsoft Excel (or other spreadsheet software), or programming languages that read .txt or .xls files — such as MATLAB, Octave, and Python. MATLAB has the `xlsread()` function and Octave has the `textread()` function.

DATA FILE COLUMN DESCRIPTIONS

When the data file is viewed in a spreadsheet program, the following columns display:

ASAP 2020 Data File Column Descriptions

Physical Adsorption	Chemical Adsorption
A. Manifold pressure (mmHg)	A. Manifold pressure (mmHg)
B. Manifold volume (cm ³)	B. Manifold volume (cm ³)
C. Manifold temperature (K)	C. Manifold temperature (K)
D. Elapsed time (ms)	D. Elapsed time (ms)
E. Analysis temperature (K)	E. Analysis temperature (K)
F. Ambient free space (cm ³ STP)	F. Free space (cm ³ STP)
G. Analysis free space (cm ³ STP)	G. Quantity dosed (cm ³ STP)
H. Quantity dosed (cm ³ STP)	H. Quantity adsorbed (cm ³ STP)
I. Quantity adsorbed (cm ³ STP)	I. Sample valve open? (1 = open, 0 = closed)
J. Sample valve open? (1 = open, 0 = closed)	J. Number of data points taken
K. Number of data points taken	K. Current pressure table index
L. Current pressure table index	L. Last data point elapsed time (ms)
M. Last data point elapsed time (ms)	M. Last data point quantity dosed (cm ³ STP)
N. Last data point quantity dosed (cm ³ STP)	N. Last data point quantity adsorbed (cm ³ STP)
O. Last data point quantity adsorbed (cm ³ STP)	
P. Last data Po (mmHg)	

INSTALL PYTHON COMPONENTS

To operate Python to view real time data, three components should be installed in the following order:

1. Install PYTHON

- Download URL: <https://www.python.org/downloads/>
- Download Python version 3.2 or later

Depending on the computer operating system, download file versions may vary, however, the .msi file should be compatible with computers that operate the ASAP 2020 analyzer.

2. Install NumPY (for numerical functions)

- Download URL: <http://sourceforge.net/projects/numpy/files/NumPy/1.6.2/>
- Download file: numpy-1.6.2-win32-superpack-python3.2.exe

NumPY contains numerous numerical functions and libraries needed to properly handle the transient data extracted from the .txt file collected during an analysis. NumPY version 1.6.2 should be download to be compatible with the installed version of Python.

3. Install MatPlotLIB (for graphical display of the data)

- Download URL: <http://www.lfd.uci.edu/~gohlke/pythonlibs/#matplotlib>
- Download file: matplotlib-1.2.1rc1.win32-py3.2.exe

MatPlotLIB version 1.2.1 is compatible with NumPY from Step 2.

SAMPLE PYTHON CODE

The following code was used to produce the data in this section. This is basic code for viewing transient data. More detailed scripts can be created to compare pressure or quantity adsorbed between ports, generate a separate figure for each port, etc. Contact Micromeritics' applications specialists to discuss and support creating custom scripts for individual applications.

```
import numpy as np
import matplotlib.pyplot as plt

myFile = 'carbon.txt'
data = np.genfromtxt(myFile, skip_header=2, skip_footer = 1)

# Time (minutes)
x=data[:,3]
x = x/1000/60

# Manifold pressure (mmHg)
y=data[:,0]

plt.plot(x,y,'ko')
plt.ylabel('Pressure (torr)')
plt.xlabel('time (minutes)')
plt.show()
```

Sample Code Explanation

```
import numpy as np
import matplotlib.pyplot as plt
```

Import is needed to load the modules containing functions to be used — in this case, numerical and plotting functions. Coding is easier if abbreviations such as *np* and *plt* are used.

```
myFile = 'carbon.txt'
data = np.genfromtxt(myFile, skip_header=2, skip_footer = 1)
```

MyFile is a variable name for the .txt file to be read. As long as the .txt file and the script file are in the same directory, the script file can run automatically by double-clicking the script file after the correct file has been hard-coded.

The `genfromtxt()` function allows for the text file to be converted into a numerical matrix. The `skip_header` setting allows for the first 2 rows of data to be excluded from the matrix. As shown in the following figure, the first row of data is ASCII *art* created by the PuTTY program, and the second row of data are the column labels — neither of which are numerical data. The `skip_footer` setting is needed because, when the .txt file is read in real time, the entire last row of data may not be complete. This causes problems for creating the matrix and needs to be excluded. This means that the last half-second of data is not displayed when the data are viewed in real time.

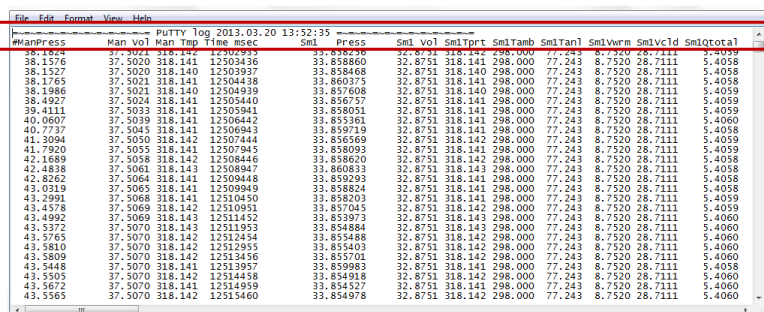

#ManPress	Man Vol	Man Tmp	File	mscc	Sml	Press	Sml Vol	SmlTPrT	SmlTamb	SmlTanI	SmlVwm	SmlVcld	SmlQtotal
38.1824	37.5024	318.142	12502933	33.858238	32.8751	318.142	298.000	77.243	8.7520	28.7111	5.4059	5.4059	
38.1576	37.5020	318.141	12502936	33.858860	32.8751	318.141	298.000	77.243	8.7520	28.7111	5.4058	5.4058	
38.1527	37.5020	318.140	12503937	33.858468	32.8751	318.140	298.000	77.243	8.7520	28.7111	5.4058	5.4058	
38.1765	37.5021	318.141	12504438	33.860375	32.8751	318.141	298.000	77.243	8.7520	28.7111	5.4058	5.4058	
38.1586	37.5021	318.140	12504939	33.857608	32.8751	318.140	298.000	77.243	8.7520	28.7111	5.4059	5.4059	
38.4927	37.5024	318.141	12505440	33.856757	32.8751	318.141	298.000	77.243	8.7520	28.7111	5.4059	5.4059	
39.4111	37.5033	318.141	12505941	33.858051	32.8751	318.141	298.000	77.243	8.7520	28.7111	5.4059	5.4059	
40.0607	37.5039	318.141	12506442	33.855361	32.8751	318.141	298.000	77.243	8.7520	28.7111	5.4060	5.4060	
40.7737	37.5045	318.141	12506943	33.859719	32.8751	318.141	298.000	77.243	8.7520	28.7111	5.4058	5.4058	
41.3094	37.5050	318.142	12507444	33.856569	32.8751	318.142	298.000	77.243	8.7520	28.7111	5.4059	5.4059	
41.7920	37.5055	318.141	12507945	33.858093	32.8751	318.141	298.000	77.243	8.7520	28.7111	5.4059	5.4059	
42.1689	37.5058	318.142	12508446	33.858620	32.8751	318.142	298.000	77.243	8.7520	28.7111	5.4058	5.4058	
42.4838	37.5061	318.143	12508947	33.860833	32.8751	318.143	298.000	77.243	8.7520	28.7111	5.4058	5.4058	
42.8262	37.5064	318.141	12509448	33.859293	32.8751	318.141	298.000	77.243	8.7520	28.7111	5.4058	5.4058	
43.0319	37.5065	318.141	12509949	33.858824	32.8751	318.141	298.000	77.243	8.7520	28.7111	5.4058	5.4058	
43.2991	37.5068	318.141	12510450	33.858203	32.8751	318.141	298.000	77.243	8.7520	28.7111	5.4059	5.4059	
43.4578	37.5069	318.142	12510951	33.857045	32.8751	318.142	298.000	77.243	8.7520	28.7111	5.4059	5.4059	
43.4992	37.5069	318.142	12511452	33.853913	32.8751	318.142	298.000	77.243	8.7520	28.7111	5.4060	5.4060	
43.5372	37.5070	318.143	12511953	33.854884	32.8751	318.143	298.000	77.243	8.7520	28.7111	5.4060	5.4060	
43.5765	37.5070	318.142	12512454	33.855488	32.8751	318.142	298.000	77.243	8.7520	28.7111	5.4060	5.4060	
43.5810	37.5070	318.142	12512955	33.855403	32.8751	318.142	298.000	77.243	8.7520	28.7111	5.4060	5.4060	
43.5809	37.5070	318.142	12513456	33.855701	32.8751	318.142	298.000	77.243	8.7520	28.7111	5.4060	5.4060	
43.5448	37.5070	318.141	12513957	33.853983	32.8751	318.141	298.000	77.243	8.7520	28.7111	5.4058	5.4058	
43.5505	37.5070	318.142	12514458	33.854918	32.8751	318.142	298.000	77.243	8.7520	28.7111	5.4060	5.4060	
43.5672	37.5070	318.141	12514959	33.854527	32.8751	318.141	298.000	77.243	8.7520	28.7111	5.4060	5.4060	
43.5565	37.5070	318.142	12515460	33.854978	32.8751	318.142	298.000	77.243	8.7520	28.7111	5.4060	5.4060	

Sample of Transient Data

Exclude the first two rows of data

```
# Time (minutes)
x=data[:,3]
x = x/1000/60
```

[Data File Column Descriptions on page E - 3](#) identifies the columns of data recorded. The fourth column of data contains time in milliseconds, however, the first index in Python is 0; therefore, `data[:,3]` captures all of the rows (:) in the fourth column.

```
plt.plot(x,y,'ko')
plt.ylabel('Pressure (torr)')
plt.xlabel('time (minutes)')
plt.show()
```

The above code shows the syntax for plotting. The label 'ko' indicates filled black circles.

CHEMICAL ADSORPTION TEMPERATURE RAMP DATA

ASAP 2020 data can be captured during chemical adsorption analyses by connecting to port 54200 (see [Data Logging on page E - 1](#)). Time and sample temperature are sent every half second when the external trigger is set to *ON*. This is typically done during a flowing preparation temperature ramp. The data columns are

- A. Time (s)
- B. Sample temperature (°C)

The *External Trigger* in the analyzer application must be enabled for this data to be available.

- To manually set the trigger go to **Unit [n] > Enable Manual Control**, right click the *External Trigger* icon and select *ON*. The box is dark when enabled.
- Enable the *Set external trigger* box in a *Preparation Flow Task* in the Analysis Conditions to collect temperature data that is synchronized with an external mass spectrometer or other detector to be started by the external trigger signal.

Blank Page

F DFT MODELS

Theories are developed by scientists in an attempt to explain a class of observed behavior. In the experimental physical sciences, theories are often expressed in terms of a model that can be visualized and described mathematically. Early models of physical adsorption were quite simple, both conceptually and mathematically, for very practical reasons — hand computations were required. Today we can explore complex models that describe adsorption systems on the atomic scale of size and sub-picosecond time frame. This is not because scientists are smarter, but because of available tools. The DFT models are created by classical approaches to adsorption as well as models based on modern statistical thermodynamics.

MODELS BASED ON STATISTICAL THERMODYNAMICS

Included in this group are methods that model the adsorption system in terms of forces acting between individual molecules.

THEORETICAL BACKGROUND

Traditional adsorption theories attempt to describe experimental adsorption isotherms with an isotherm equation containing a small number of parameters. At a minimum, these parameters include the extent of the surface, such as the monolayer capacity (V_m), and the molar intensity of the gas-surface interaction, such as the Langmuir “K” constant or the BET “C” constant. In some equations, additional parameters take into account the lateral interaction of adsorbed molecules with each other. Other theories, such as the Dubinin-Astakhov approach, also include parameters for the effect of adsorbent porosity.

Instead of this classical kinetic or phenomenological approach, we can use a molecular-based statistical thermodynamic theory that allows us to relate the adsorption isotherm to the microscopic properties of the system: the fluid-fluid and fluid-solid interaction energy parameters, the pore size, the pore geometry, and the temperature.

The following example is given so that you may understand how such a theory is constructed:

A clean sample of a solid material containing slit-shaped pores of a single width is placed in an evacuated space. It is kept at a fixed temperature as a known quantity of pure argon gas is admitted into the space surrounding the sample. The pressure within the space is recorded over time. In this situation, the pressure falls rapidly from its initial value and gradually approaches a steady reading, called the equilibrium pressure. The amount adsorbed corresponds to the quantity of gas effectively removed from the gas phase by the solid surface. A graph that plots amount adsorbed versus equilibrium pressure is called an adsorption isotherm.

Under such conditions, the argon atoms that randomly enter the pore space feel the presence of the solid surface as the action of an external attractive force (the dispersion forces or Van der Waal's forces) and spend more time near the surface. As a result, the space near the surface acquires a greater average density of argon atoms than regions farther removed.

If the equilibrium distribution of the gas atoms near the surface could be described as a function of pressure and the molecular properties of the components of the system, then a model could be constructed for the adsorption isotherm for the system. Modern physical chemistry provides several ways to calculate this distribution. All these methods are based on the fundamental thermodynamic law that such a system adopts a configuration of minimum free energy at equilibrium. Also needed is a description of the pairwise interaction energy between atoms, $U(s)$, commonly given by a Lennard-Jones potential:

$$U(s) = 4\epsilon\left(\frac{\sigma}{s}\right)^{12} - \left(\frac{\sigma}{s}\right)^6$$

where

ϵ = a characteristic energy of the adsorptive,
 σ = the diameter of the adsorptive molecule, and
 s = the separation distance.

MOLECULAR SIMULATION METHODS

Two simulation techniques are commonly used to determine the distribution of gas molecules in a system in equilibrium: the molecular dynamics method and the Monte Carlo method. Both of these are used as reference methods because their results are considered exact.

MOLECULAR DYNAMICS METHOD

In the molecular dynamics method, the position and velocity of individual gas particles are calculated over time at very short intervals. This method takes into account both the forces acting between the gas particles themselves and those acting between the gas particles and the atoms of the simulated surface. As the simulated particles collide with each other and with the surface, the average concentration of particles in the space near the surface is calculated; this calculation yields the amount of gas adsorbed.

This method can be thought of as a way to determine the chronological record of the movement of each particle in the system using time steps of 10-14 seconds. Although the mathematics are simple, the number of calculations required for a system of even a few hundred particles is astronomical and challenges even the fastest computers.

MONTE CARLO METHOD

In the Monte Carlo method, determination of the system equilibrium distribution begins with an assumption (which may be only approximate) about the initial configuration of particles in the system. The system is “equilibrated” through a process of randomly selecting one particle and conditionally moving it a random distance in a random direction.

If the move results in a configuration of *lower total energy*, then the move is completed and another particle is randomly selected to be moved.

If the move results in a configuration of *higher energy*, a probability for that event is calculated, and a random number between zero and one is generated. If the generated number is smaller than the probability of the event, then the move is accepted; otherwise, another particle is selected and the process is repeated. This process continues until the average total energy of the system no longer decreases; at this point, average configuration data are accumulated to yield the mean density distribution of particles in the system.

Monte Carlo simulations require considerably less computation time than molecular dynamic simulations and can yield the same results; however, neither method provides a really practical way to calculate complete isotherms.

DENSITY FUNCTIONAL FORMULATION

Density functional theory offers a practical alternative to both molecular dynamic and Monte Carlo simulations. When compared to reference methods based on molecular simulation, this theory provides an accurate method of describing inhomogeneous systems yet requires fewer calculations. Because the density functional theory provides accuracy and a reduced number of calculations, it is the basis embodied in the DFT models.

The system being modeled consists of a single pore represented by two parallel walls separated by a distance H . The pore is open and immersed in a single component fluid (adsorptive) at a fixed temperature and pressure. Under such conditions, the fluid responds to the walls and reaches an equilibrium distribution. In this condition (by the definition of equilibrium), the chemical potential at every point equals the chemical potential of the bulk fluid. The bulk fluid is a homogenous system of constant density; its chemical potential¹⁾ is determined by the pressure of the system using well-known equations. The fluid near the walls is not of constant density; its chemical potential is composed of several position-dependent contributions that must total at every point to the same value as the chemical potential of the bulk fluid.

¹⁾ Chemical potential may be thought of as the energy change felt by a probe particle when it is inserted into the system from a reference point outside the system. It can also be defined as the partial derivative of the grand potential energy with respect to density (or concentration).

As noted previously, at equilibrium, the whole system has a minimum (Helmholtz) free energy, known thermodynamically as the grand potential energy (GPE). Density functional theory describes the thermodynamic grand potential as a functional of the single-particle density distribution; therefore, calculating the density profile that minimizes the GPE yields the equilibrium density profile. The calculation method requires the solution of a system of complex integral equations that are implicit functions of the density vector. Since analytic solutions are not possible, the problem must be solved using iterative numerical methods. Although calculations using these methods still require supercomputing speed, the calculation of many isotherm pressure points for a wide range of pore sizes is a feasible task. The complete details of the theory and the mathematics can be found in the papers listed under [DFT Model References on page F - 17](#).

The following graphs and accompanying text illustrate the results of using density functional theory to predict the behavior of a model system.

Figure 1 shows the density profile for argon at a carbon surface as calculated by density functional theory for a temperature of 87.3 K and a relative pressure of about 0.5.

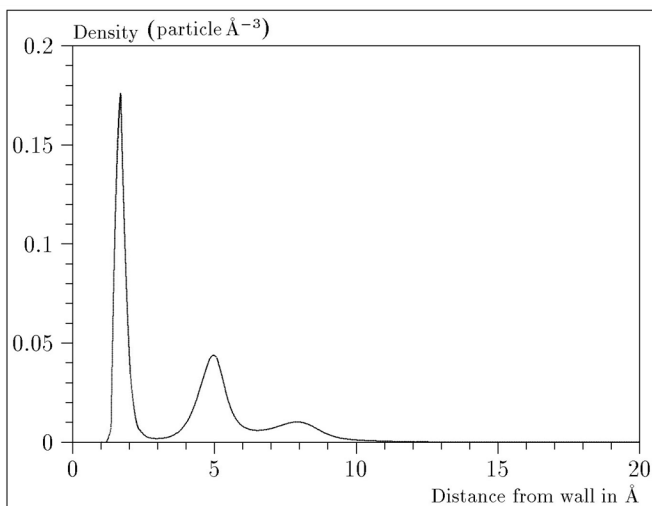

Figure 1. Density Profile for Argon on Carbon at 87.3 K and a Relative Pressure of 0.5

This figure represents a cross-section of the region near the surface. Note the layerwise distribution of adsorbate; the first monolayer is sharply defined and a third layer can be distinguished. The area under the profile curve represents the amount adsorbed per unit area at this pressure. The positions of the maxima are separated by a distance determined by the size of the adsorptive atom.

Given the density profile, the amount adsorbed at the stated pressure can be easily calculated as the integral over the profile. Repeating this calculation over a range of pressures yields the adsorption isotherm for the model. If the value of H is very large, the isotherm obtained corresponds to that of an external, or *free*, surface. If H is smaller, a range of pressures is reached where two minima exist for the grand potential, showing the presence of two metastable phases having different density distributions but the same chemical potential. The phase with the lower GPE is the stable one. As the pressure is increased, a point is reached where the other phase becomes the stable one. This phase transition reflects condensation of adsorbate in the pore; the pressure at which it occurs is called the *critical pore-filling pressure*. This pressure is analogous to the condensation pressure predicted by the Kelvin equation in the classical model of pore filling.

Figure 2 shows how the profiles change with pressure for a model pore with $H = 40$ angstroms. The inset shows the density profiles for the corresponding points of the isotherm.

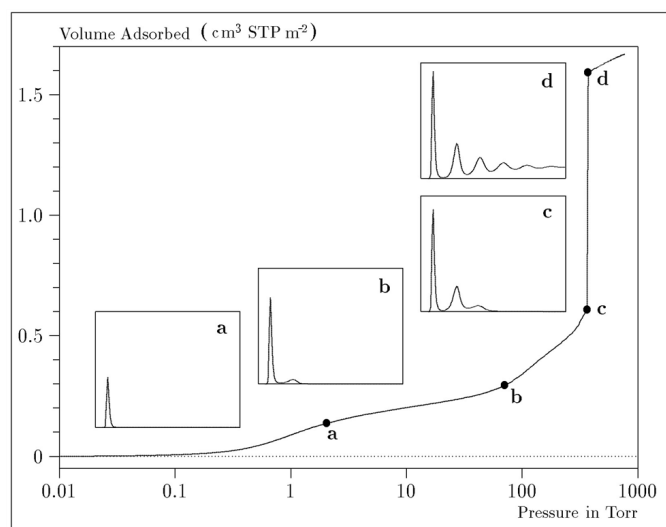

Figure 2. Model Isotherm for Argon at 87.3 K in a 40 Å Slit in a Carbon Substrate

The profiles show the density distribution from one wall to the center of the slit; the other half of the distribution is a mirror image of the profile shown.

As the pressure is first increased from zero, almost all the adsorbed atoms occupy a position close to the surface.

- Inset **a** shows the profile corresponding to point a on the isotherm where the surface is about half covered.
- At point **b**, the first layer is so full that it is more favorable for atoms to start a new layer.
- At point **c**, a third layer is forming. Point **c**, for this size slit, is the critical pore-filling pressure. In inset **c**, the profile shows the density decreasing to near zero (actually the bulk gas density) at 4 or 5 molecular diameters from the surface.
- Inset **d** shows the profile converging on a density similar to that of bulk liquid argon in the center of the pore, indicating a phase transition.

Note that the adsorption isotherms for pores larger than the one shown in the previous graph is identical up to point **c**. The lower branch of the isotherm simply continues to a higher pressure for larger pores. This trend is illustrated in the Figure 3, where isotherms for some larger size pores are shown. It is clear that pore size is uniquely characterized by a corresponding critical pore-filling pressure. At large pore sizes, density functional theory produces results for the critical filling pressures that are in good agreement with those produced by the Kelvin equation.

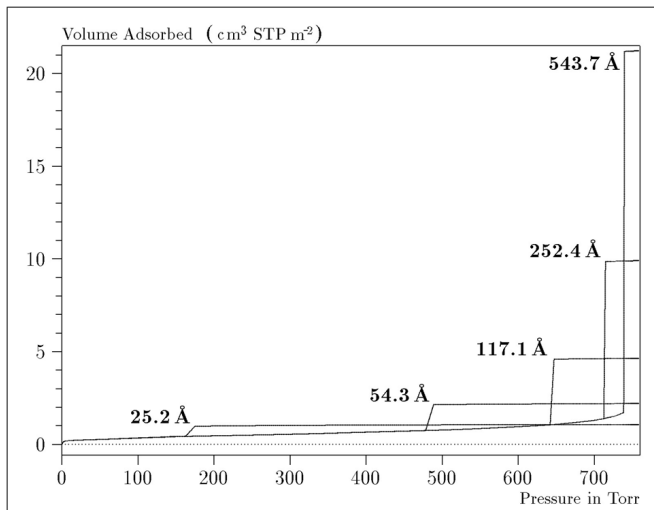

Figure 3. Model Isotherms for Some Larger Pore Widths Argon on Carbon at 87.3 K

Figure 4 shows model isotherms for pores in the micropore size range. Note the logarithmic scale for pressure.

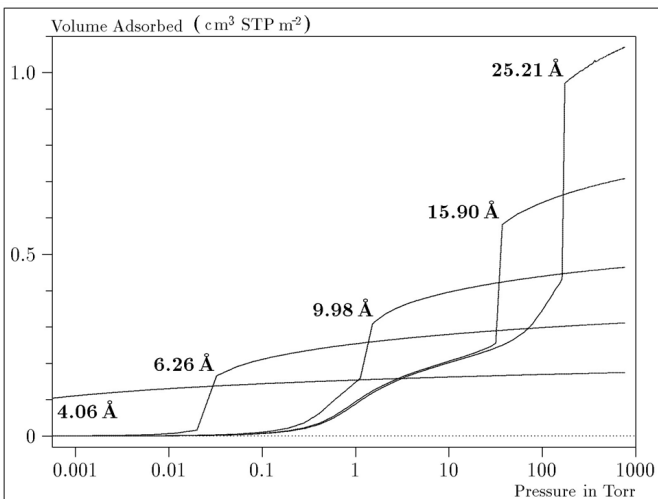

Figure 4. Model Isotherms in the Micropore Size Range of Pore Width Argon on Carbon at 87.3 K

Pores of 4 Å width, barely larger than the argon atom (3.38 Å), fill at pressures below 1 millitorr. Pores below 15 Å fill before a monolayer is completed on the surface of the larger pores. In the micropore size range, the pore volume fills more gradually with pressure and the total shape of the isotherm is important in characterizing the pore size.

Models Included

Non-Local Density Functional Theory with Density-Independent Weights

N2 - DFT Model

AR - DFT Model

Geometry:	Slit
Substrate:	Carbon (graphite)
Category:	Porosity
Method:	Nitrogen at 77 K; Argon at 87 K

Using the methods of non-local density functional theory, two sets of isotherms have been calculated to serve as kernel functions for the characterization of porous solids from adsorption data. The model isotherms are stored in binary format files. These models assume a *slit-like pore geometry*. The pore size range from 4.0 to 4000 Å is covered in 91 classes in a geometric progression. The class intervals are rounded to the nearest 0.02 molecular diameters. A model for the free or external surface is included to account for unfilled pores. Each of the 92 model isotherms has been calculated at 181 pressure points from near 1×10^{-6} to near 1.00 relative pressure.

These models are identical to those supplied with the original DOS version of DFT software. Some slight difference from the DOS results may be noted when they are applied to the same data due to improvements in the deconvolution algorithm and better regularization of the current software.

Non-Local Density Functional Theory with Density-Dependent Weights

N2 - Modified Density Functional

Geometry:	Free surface
Substrate:	Surface energy
Method:	Nitrogen at 77K

Using the modified Tarazona prescription described by Olivier (see [DFT Model References on page F - 17](#) [items 3 and 4]), model isotherms were calculated for a wide range of adsorptive energies to a relative pressure of 0.6. The model makes no provision for pore filling in the micropore region. If the sample solid contains small mesopores, the isotherm data should be truncated (using the *Select Data Points* window) to a suitably low relative pressure to avoid trying to fit this region; mesopore filling reports as a large area of low energy in the calculated distribution of adsorptive potential.

The surface energy is reported in terms of the effective Lennard-Jones interaction parameter, i.e., for the adsorptive / adsorbent pair divided by Boltzmann constant. The units are therefore Kelvin.

N2 - Cylindrical Pores - Oxide Surface

AR - Cylindrical Pores - Oxide Surface

Geometry:	Cylinder
Substrate:	Oxide
Category:	Porosity
Method:	Nitrogen at 77K; Argon at 87K

Model isotherms were calculated using a combination of statistical mechanical calculations and experimental observations for macroporous silicas and MCM-41 mesoporous silicas as well as zeolites. The pore-filling pressures were determined as a function of the pore size from adsorption isotherms on MCM-41 materials characterized by X-ray and other techniques. The variation of the pore fluid density with pressure and pore size has been accounted for by density functional theory calculations. The N2 model reports pore sizes ranging from 3.8 to 387 Å and the AR model from 3.8 to over 500 angstroms.

References: M. Jaroniec, M. Kruk, J.P. Olivier, and S. Koch, "A New Method for the Accurate Pore Size Analysis of MCM-41 and Other Silica-Based Mesoporous Materials," Proceedings of COPS-V, Heidelberg, Germany (1999).

N2 – Cylindrical Pores – Pillared Clay Surface (Montmorillonite)

Geometry:	Cylinder
Substrate:	Crystalline Silicate
Category:	Porosity
Method:	Nitrogen at 77K

Model isotherms were calculated using a combination of statistical thermodynamic Non-Local Density Functional Theory (NLDFE) calculations and experimental isotherms for reference samples of montmorillonite. The construction method for the hybrid models was analogous to that described in the first reference below (Jaroniec et al, 1999). The additional references add additional theoretical details as well as examples of the application of the model to pillared clay catalysts. This model reports pore widths from 3.8 to 387 angstroms.

References: Mietec Jaroniec, Michal Kruk, James P. Olivier and Stefan Koch, "A New Method for the Characterization of Mesoporous Silicas," Proceedings of COPS-V, 1999, Studies in Surface Science, Vol 128, *Characterization of porous Solids V*, Unger, et al, Eds, Elsevier, Amsterdam, 2000.

James P. Olivier and Mario L. Occelli, "Surface Area and Microporosity of a Pillared Interlayered Clay (PILC) from a Hybrid Density Functional Theory

(DFT) Method," *The Journal of Physical Chemistry B*; 2001, 105(3), 623-629.

M. L. Occelli, J. P. Olivier, J. A. Perdigon-Melon, and A. Auroux, "Surface Area, Pore Volume Distribution, and Acidity in Mesoporous Expanded Clay Catalysts from Hybrid Density Functional Theory (DFT) and Adsorption Microcalorimetry Methods," *Langmuir* 2002, 18, 9816-9823.9b.

James P. Olivier, "The Importance of Surface Heterogeneity in Developing Characterization Methods." *6th International Symposium on the Characterization of Porous Solids*, Studies in Surface Science and Catalysis 144, Elsevier, 2002.

James P. Olivier and Mario L. Occelli, "Surface Area and Microporosity of Pillared Rectorite Catalysts from a Hybrid Density Functional Theory Method," *Microporous and Mesoporous Materials* 2003, 57, 291-296.

C02 - DFT Model

Geometry: Slit
Substrate: Carbon
Category: Porosity
Method: Carbon dioxide at 273 K

Model isotherms were calculated using the non-local prescription of Tarazona, employing molecular parameters derived from the known bulk properties of carbon dioxide.

AR - Modified Density Functional Model

Geometry: Free surface
Substrate: Any
Category: Surface energy
Method: Argon at 87K

This model was produced in the same manner as the N2 Modified Density Functional model listed earlier, except applicable to argon adsorbed at 87.3 K.

N2 - Tarazona NLDFT, Esf = 30.0K

Geometry: Cylinder
Substrate: Oxide
Category: Porosity
Method: Nitrogen at 77K

Model isotherms were calculated using the prescriptions of Tarazona for density dependent weighting functions and a cylindrical pore geometry. The wall potential used is $k = 30$ K, typical for a silica or alumina surface.

This model file is particularly useful for sizing zeolites or zeolite containing materials that have substantial micropore volume. The reported pore size range is 3.8 to 387 angstroms.

References: P. Tarazona, Phys. Rev. A 31: 2672 (1985).
Idem, Phys. Rev. A 32: 3148 (1985).
P. Tarazona, U. M. B. Marconi, and R. Evans, Mol. Phys. 60: 573 (1987).

N2 - Carbon Slit Pores by NLDFT

Ar - Carbon Slit Pores by NLDFT

Geometry: Slit
Substrate: Carbon
Category: Porosity
Method: Nitrogen at 77K; Argon at 87K

Model isotherms were calculated using the prescriptions of Tarazona for density dependent weighting functions and a slit-like pore geometry. These models are slightly different from N2-DFT and Ar-DFT models that were calculated using NLDFT with density independent weighting functions.

The reported pore size range is from 3.5 to 1000 angstroms.

References: P. Tarazona, Phys. Rev. A 31: 2672 (1985).
Idem, Phys. Rev. A 32: 3148 (1985).
P. Tarazona, U. M. B. Marconi, and R. Evans, Mol. Phys. 60: 573 (1987).

N2 - Carbon Finite Pores, As=6, 2D-NLDFT

Ar - Carbon Finite Pores, As=6, 2D-NLDFT

Geometry: Finite Slit
Substrate: Carbon
Category: Porosity
Method: Nitrogen at 77K; Argon at 87K

Model isotherms were calculated using the prescriptions of Tarazona for density dependent weighting functions assuming 2D model of finite slit pores having a diameter-to-width aspect ratio of 6.

This model is particularly useful for microporous carbon materials. The reported pore size range is from 3.5 to 250 angstroms.

References: Jacek Jagiello and James P. Olivier. "A simple two-dimensional NLDFT model of gas adsorption in finite carbon pores. Application to pore structure analysis." The Journal of Physical Chemistry C, 113(45):19382-19385, 2009.

N2 - Carbon Finite Pores, As=12, 2D-NLDFT

Ar - Carbon Finite Pores, As=12, 2D-NLDFT

Geometry: Finite Slit
Substrate: Carbon
Category: Porosity
Method: Nitrogen at 77K; Argon at 87K

Model isotherms were calculated using the same methods and assumptions that were used in the model above except in this model, the aspect ratio is equal to 12.

These two finite pore models may be used as a research tool in conjunction with independent analytical techniques such as high-resolution transmission electron microscopy (HRTEM) and/or X-ray diffraction (XRD) to obtain comprehensive information about the structure of studied carbon material.

References: Jacek Jagiello and James P. Olivier. "A simple two-dimensional NLDFT model of gas adsorption in finite carbon pores. Application to pore structure analysis." The Journal of Physical Chemistry C, 113(45):19382-19385, 2009.

N2 - Carbon Cylinder, single-wall nanotube by NLDFT

Ar - Argon Cylinder, single-wall nanotube by NLDFT

Geometry: Cylinder
Substrate: Carbon
Category: Porosity
Method: Nitrogen at 77 K; Argon at 87 K

Model isotherms were calculated using the prescriptions of Tarazona for density dependent weighting functions and cylindrical pore geometry. The pore wall potential is described by the Lennard-Jones potential of interaction between a gas molecule and the graphitic surface of an infinitely long cylinder.

This model is particularly useful for characterizing carbon single-wall nanotubes. The reported pore size range is from 3.5 to 1000 angstroms.

References: P. Tarazona, Phys. Rev. A 31: 2672 (1985).
Idem, Phys. Rev. A 32: 3148 (1985).
P. Tarazona, U. M. B. Marconi, and R. Evans, Mol. Phys. 60: 573 (1987).

N2 - Carbon Cylinder, multi-wall nanotube by NLDFT
Ar - Argon Cylinder, multi-wall nanotube by NLDFT

Geometry:	Cylinder
Substrate:	Carbon
Category:	Porosity
Method:	Nitrogen at 77 K; Argon at 87 K

Model isotherms were calculated using the prescriptions of Tarazona for density dependent weighting functions and cylindrical pore geometry. The pore wall potential is described by the Lennard-Jones potential of interaction between a gas molecule and multiple concentric graphitic surfaces of infinitely long cylinders.

This model is particularly useful for characterizing carbon multi-wall nanotubes. The reported pore size range is from 3.5 to 1000 angstroms.

References:	P. Tarazona, Phys. Rev. A 31: 2672 (1985). Idem, Phys. Rev. A 32: 3148 (1985). P. Tarazona, U. M. B. Marconi, and R. Evans, Mol. Phys. 60: 573 (1987)
--------------------	---

Ar - Zeolites H-Form by NLDFT

Geometry:	Cylinder
Substrate:	Zeolite
Category:	Porosity
Method:	Argon at 77 K

Model isotherms were calculated using the prescriptions of Tarazona for density dependent weighting functions and cylindrical pore geometry. The pore wall potential is described by the Lennard-Jones potential of interaction between a gas molecule and the oxide surface of an infinitely long cylinder.

This model is particularly useful for characterizing oxides and H⁺ and (NH₄)⁺ exchanged zeolites. The reported pore size range is from 3.5 to 300 angstroms.

Ar - Zeolites Me-Form by NLDFT

Geometry:	Cylinder
Substrate:	Zeolite
Category:	Porosity
Method:	Argon at 77 K

Model isotherms were calculated using the prescriptions of Tarazona for density dependent weighting functions and cylindrical pore geometry. The pore wall potential is described by the Lennard-Jones potential of interaction between a gas molecule and the oxide surface of an infinitely long cylinder.

This model is similar to the model above, but it more appropriate is for characterizing alkali metal exchanged zeolites. The reported pore size range is from 3.5 to 300 angstroms.

MODELS BASED ON CLASSICAL THEORIES

Both surface energy distribution and pore size distribution may be evaluated using classical approaches to model kernel functions for use with equation (1) of the DFT Theory. (Log in to your [customer portal](#) to access the Calculations document.) Be aware that the deconvolution method only provides a fitting mechanism; it does not overcome any inherent shortcomings in the underlying theory.

SURFACE ENERGY

The use of classical theories to extract adsorptive potential distribution is mostly of historical interest. At a minimum, the equation must contain a parameter dependent on adsorption energy and another dependent on monolayer capacity or surface area. This is sufficient to permit the calculation of the set of model isotherms that is used to create a library model. The Langmuir equation has been used in the past, as have the Hill-de Boer equation and the Fowler-Guggenheim equation. All of these suffer from the fact that they only describe monolayer adsorption, whereas the data may include contributions from multilayer formation.

PORE SIZE

It is well established that the pore space of a mesoporous solid fills with condensed adsorbate at pressures somewhat below the prevailing saturated vapor pressure of the adsorptive. When combined with a correlating function that relates pore size with a critical condensation pressure, this knowledge can be used to characterize the mesopore size distribution of the adsorbent. The correlating function most commonly used is the Kelvin equation. Refinements make allowance for the reduction of the physical pore size by the thickness of the adsorbed film existing at the critical condensation pressure. Still further refinements adjust the film thickness for the curvature of the pore wall.

The commonly used practical methods of extracting mesopore distribution from isotherm data using Kelvin-based theories, such as the BJH method, were for the most part developed decades ago and were designed for hand computation using relatively few experimental points. In general, these methods visualize the incremental decomposition of an experimental isotherm, starting at the highest relative pressure or pore size. At each step, the quantity of adsorptive involved is divided between pore emptying and film thinning processes and exactly is accounted for. This computational algorithm frequently leads to inconsistencies when carried to small mesopore sizes. If the thickness curve used is too steep, it finally will predict a larger increment of adsorptive for a given pressure increment than is actually observed; since a negative pore volume is non-physical, the algorithm must stop. Conversely, if the thickness curve used underestimates film thinning, accumulated error results in the calculation of an overly large volume of (possibly nonexistent) small pores.

The use of equation (1) represents an improvement over the traditional algorithm. Kernel functions corresponding to various classical Kelvin-based methods have been calculated for differing geometries and included in the list of models.

MODELS INCLUDED

Kelvin Equation with Halsey Thickness Curve

N2 - Halsey Thickness Curve

Geometry:	Slit
Substrate:	Average
Category:	Porosity
Method:	Nitrogen 77 K

The kernel function is calculated using the Halsey equation with standard parameters:

$$t = 3.54 \left(\frac{-5.00}{\ln(P/P_0)} \right)^{1/3}$$

The nitrogen properties used in the Kelvin equation are:

Surface tension =	8.88 dynes cm ⁻¹
Molar density =	0.02887 g cm ⁻³

N2 - Halsey Thickness Curve

Geometry:	Cylinder
Substrate:	Average
Category:	Porosity
Method:	Nitrogen 77 K

The calculation is the same as above except that cylindrical geometry is assumed.

Reference: G. Halsey, J. Chem. Phys 16, 931 (1948).

Kelvin Equation with Harkins and Jura Thickness Curve

N2 - Harkins and Jura Thickness Curve

Geometry: Slit
Substrate: Average
Category: Porosity
Method: Nitrogen 77 K

The kernel function is calculated using the Harkins and Jura equation with standard parameters:

$$t = 3.54 \left(\frac{13.99}{0.034 - \log(P/P_0)} \right)^{1/2}$$

The nitrogen properties used in the Kelvin equation are:

Surface tension = 8.88 dynes cm⁻¹
Molar density = 0.02887 g cm⁻³

N2 - Harkins and Jura Thickness Curve

Geometry: Cylinder
Substrate: Average
Category: Porosity
Method: Nitrogen 77 K

The calculation is the same as above except that cylindrical geometry is assumed.

References: W. D. Harkins and G. Jura, J.A.C.S. 66, 1366 (1944).
 J. H. DeBoer et al., J. Colloid and Interface Sci. 21, 405 (1966).

Kelvin Equation with Broekhoff-de Boer Thickness Curve

N2 - Broekhoff-de Boer Model

Geometry: Cylinder
Substrate: Average
Category: Porosity
Method: Nitrogen 77 K

The kernel function is calculated using the Broekhoff-de Boer equation with standard parameters:

$$\log\left(p/p^0\right) = \frac{-16.11}{t^2} + 0.1682^{-0.1137t}$$

The nitrogen properties used in the Kelvin equation are:

Surface tension =	8.88 dynes cm ⁻¹
Molar density =	0.02887g cm ⁻³

N2 - Broekhoff-de Boer Model

Geometry:	Cylinder
Substrate:	Average
Category:	Porosity
Method:	Nitrogen 77 K

The calculation is similar to the above except that cylindrical geometry is assumed, and the film thickness depends on pore size (see reference).

References:	Specifically, equations 20 and 21 in: J.C.P. Broekhoff and J.H. de Boer, "The Surface Area in Intermediate Pores," Proceedings of the International Symposium on Surface Area Determination, D.H. Everett, R.H. Ottwill, eds., U.K. (1969).
--------------------	---

DFT MODEL REFERENCES

The papers listed below provide additional information on DFT models:

1. "Determination of Pore Size Distribution from Density Functional Theoretic Models of Adsorption and Condensation within Porous Solids," J.P. Olivier and W.B. Conklin, Micromeritics Instrument Corp; presented at the International Symposium on the Effects of Surface Heterogeneity in Adsorption and Catalysts on Solids, Kazimierz Dolny, Poland (July 1992).
2. "Classification of Adsorption Behavior: Simple Fluids in Pores of Slit-shaped Geometry," Perla B. Balbuena and Keith E. Gubbins, *Fluid Phase Equilibria*, 76, 21-35, Elsevier Science Publishers, B.V., Amsterdam (1992).
3. "Modeling Physical Adsorption on Porous and Nonporous solids Using Density Functional Theory," J.P. Olivier, *Journal of Porous Materials*, 3, 9-17 (1995).
4. "The Determination of Surface Energetic Heterogeneity Using Model Isotherms Calculated by Density Functional Theory," J.P. Olivier; presented at the Fifth International Conference on the Fundamentals of Adsorption, Pacific Grove, CA (1995).

Blank Page

G EXPORTED DATA EXAMPLE

PHYSICAL ADSORPTION

Sample Information

Method: Default
Sample: Alumina 004/16816/00 (Lot 152624-14)
Operator: H. Harmon/jch
Submitter: SN3001
Mass type: Calculated
Empty tube: 38.8290 g
Sample + tube: 41.0238 g
Sample mass: 2.1948 g
Density: 1.000 g/cm³
Type of data: Automatically collected
Instrument type: 2020
original instrument type: 2020
Comments: Nitrogen Adsorbate

Sample Tube

Sample tube: Sample Tube
warm free space: 1.0000 cm³
Cold free space: 1.0000 cm³
Non-ideality factor: 0.0000620
Use isothermal jacket: Yes
use filler rod: Yes
vacuum seal type: None

Degas Conditions

Degas conditions: Degas Conditions

Evacuation Phase

Temperature ramp rate: 10.0 °C/min
Target temperature: 400 °C
Evacuation rate: 5.0 mmHg/s
Unrest. evacuation from: 5.0 mmHg
vacuum level: 1.000000e-02 mmHg
Evacuation time: 10 min

Heating Phase

Ramp rate: 10.0 °C/min
Hold temp: 400 °C
Hold time: 60 min

Evacuation and Heating Phases

Hold pressure: 100 mmHg

Backfill

Backfill sample tube: Yes

Analysis conditions: Run Conditions
 Absolute pressure dosing: No

Pressure Table

Starting Pressure (P/Po)	Pressure Increment (P/Po)	Ending Pressure (P/Po)
0.000000000	0.050000000	0.300000000

Preparation

Unrestricted Fast evacuation: No
 evacuation from: 5.0 mmHg
 Vacuum setpoint: 10 µmHg
 Evacuation time: 0.25 h

Leak test: No
 Use TranSeal: No

Free Space

Measured before analysis
 Lower Dewar for evacuation: Yes
 Evacuation time: 0.10 h
 Outgas test: No

Po and Temperature

Po type: Measured in Psat tube for each point
 Temperature type: Entered
 Temperature: 77.300 K

Dosing

Use first pressure fixed dose: No
 Use maximum volume increment: No
 Target tolerance: 2.0% or 2.000 mmHg
 Low pressure dosing: No

Equilibration

Relative Pressure (P/Po)	Equilibration Interval (s)
1 1.000000000	10

Minimum equilibration delay at P/Po >= 0.995: 600 s

Sample Backfill

Backfill at start of analysis: Yes
 Backfill at end of analysis: Yes
 Backfill gas: N2

Adsorptive Properties

```

      Adsorptive:          nitrogen (N2)
    Non-condensing adsorptive: No
    Maximum manifold pressure: 925.00 mmHg
  Therm. tran. hard-sphere diameter: 3.5770 Å
    Molecular cross-sectional area: 0.162 nm²
    Adsorbate molecular weight: 28.01
      Thermal conductivity: 1.00
    Real gas equation of state
  Adsorbed-phase free-space correction: Yes
      Fluid properties: C:\2020\NITROGEN.FPI
    Dosing method: Normal
  
```

Psat vs. Temperature Table

	Saturation Pressure (mmHg)	Temperature (K)

1	607.192	75.50
2	645.818	76.00
3	686.302	76.50
4	728.702	77.00
5	737.417	77.10
6	746.211	77.20
7	755.085	77.30
8	764.040	77.40
9	773.075	77.50
10	819.481	78.00

Report Options

```

      Report options:      Report Options
    Show report title:    Yes
      Report title:
    Show graphic:        Yes
      Graphic file:       miclogo.emf
      Graphic height:     0.250 in
      Graphic width:      2.000 in
  Apply thermal transpiration correction: No
  
```

Summary: Yes

Surface Area

```

    Single-point BET:      Yes
    Multi-point BET:      Yes
      Langmuir:           No
    t-Plot Micropore:     No
    t-Plot External:      No
  BJH Cumulative Adsorption: No
  BJH Cumulative Desorption: No
    D-H Cum. Adsorption:  No
    D-H Cum. Desorption:  No
  
```

Pore Volume

Adsorption Total: No
 Desorption Total: No
 t-Plot Micropore: No
 BJH Cum. Adsorption: No
 BJH Cum. Desorption: No
 D-H Cum. Adsorption: No
 D-H Cum. Desorption: No

Pore Size

Average pore diameter: No
 BJH adsorption avg.: No
 BJH desorption avg.: No
 D-H adsorption avg.: No
 D-H desorption avg.: No

other

Freundlich: No
 Temkin: No
 Alpha-S method: No
 DFT Pore Size: No
 DFT Surface Energy: No
 Nanoparticle Size: No

Horvath-Kawazoe

Maximum pore volume: No
 Median pore width: No

Dubinin-Radushkevich

Micropore surface area: No
 Monolayer capacity: No

Dubinin-Astakhov

Micropore surface area: No
 Limiting micropore volume: No

MP-Method

Cumulative surface area: No
 Cumulative pore volume: No
 Average pore hydraulic radius: No

Pass/Fail

Pass/Fail 1: S A:Single-point BET:
 High Range Value: 0.2600 m²/g
 High Range Message: SP UL
 Low Range Value: 0.2000 m²/g
 Low Range Message: SP LL
 Pass/Fail 2: S A:Multi-point BET:
 High Range Value: 0.2700 m²/g
 High Range Message: MP UL
 Low Range Value: 0.2100 m²/g
 Low Range Message: MP LL
 Pass/Fail 3: No
 Pass/Fail 4: No

Isotherm: Yes

Isotherm Reports

Elapsed time:	Yes
Time between points:	No
Plot adsorption branch:	Yes
Plot desorption branch:	Yes
Quantity adsorbed:	Per Gram
Tabular report selected:	Yes
Linear plot selected:	Yes
Logarithmic plot selected:	Yes
Linear absolute plot selected:	Yes
Pressure composition plot selected:	Yes

Isotherm Linear Plot axis data

Plot curve:	Yes
Plot points:	Yes
Overlay samples:	No
Autoscale X axis:	Yes
Autoscale Y axis:	Yes

Isotherm Log Plot axis data

Plot curve:	Yes
Plot points:	Yes
Overlay samples:	No
Autoscale X axis:	Yes
Autoscale Y axis:	Yes

Isotherm Linear Absolute Plot axis data

Plot curve:	Yes
Plot points:	Yes
Overlay samples:	No
Autoscale X axis:	Yes
Autoscale Y axis:	Yes

Isotherm Log Absolute Plot axis data

Plot curve:	Yes
Plot points:	Yes
Overlay samples:	No
Autoscale X axis:	Yes
Autoscale Y axis:	Yes

Isotherm Pressure Composition axis data

Plot curve:	Yes
Plot points:	Yes
Overlay samples:	No
Autoscale X axis:	Yes
Autoscale Y axis:	Yes

BET: Yes

BET: Yes

BET Reports

Tabular report selected: Yes
Transform plot selected: Yes
 Overlay Samples: No
 Autoscale X axis: Yes
 Autoscale Y axis: Yes

Isotherm plot selected: No
 Overlay Samples: No
 Autoscale X axis: Yes
 Autoscale Y axis: Yes

Fit pressure range: 0.050000000 to 0.300000000 P/Po

Langmuir: No

Freundlich: No

Temkin: No

t-Plot: No

Alpha-S Method: No

f-Ratio Method: No

BJH Adsorption: No

BJH Desorption: No

Dollimore-Heal Adsorption: No

Dollimore-Heal Desorption: No

Horvath-Kawazoe: No

NLDFT Advanced PSD: No

DFT Pore Size: No

DFT Surface Energy: No

Dubinin: No

Dubin: No

MP-Method: No

Advanced Rpt.: No

Options: No

Sample Log: Yes

Validation: No

Manufacturing: No

Collected Data

Start time: 10/30/2014 2:50:40 PM
End time: 10/30/2014 4:41:59 PM
Type of instrument: E
Unit number: 1
Serial number: 3001
Analysis conditions modified: No

Po and Temperature

Po type: Measured in Psat tube for each point
Average Po: 739.890 mmHg
Temperature type: Entered
Temperature: 77.300 K

Psat measurements

	Run time (min)	Pressure (mmHg)
--		
1	63	740.054
2	79	739.853
3	81	739.841
4	83	739.826
5	85	739.853
6	88	739.879
7	90	739.923

Free Space

warm free space: Measured before analysis
15.4586 cm³
cold free space: 44.7536 cm³

Isotherm Data Table

Absolute Pressure (mmHg)	Quantity Dosed (mmol)	Quantity Adsorbed (mmol/g)	Run Time (min)
38.165455	0.10588	0.00247	79
73.716278	0.20036	0.00274	81
110.708160	0.29885	0.00293	83
148.010361	0.39851	0.00313	85
184.897751	0.49737	0.00329	88
221.801132	0.59670	0.00349	90

sample log

sample log

Date Time Log Message

Date	Time	Log Message
10/30/2014	11:09:32 AM	Degas operation started on Unit 1 - S/N: 3001.
10/30/2014	11:09:32 AM	Started evacuation at 5.0 mmHg/s to 10 µmHg, he
10/30/2014	11:23:30 AM	Started temperature ramp at 10.0 °C/min to 400
10/30/2014	11:48:20 AM	Started temperature hold at 400 °C for 60 minut
10/30/2014	12:48:21 PM	Started cool-down wait.
10/30/2014	1:35:27 PM	Started backfilling.
10/30/2014	1:35:49 PM	Degas operation done.
10/30/2014	2:50:40 PM	Analysis on file C:\ASAP 2020 Plu...\SN3001 A1
10/30/2014	4:41:59 PM	Analysis on file C:\ASAP 2020 Plu...\SN3001 A1

CHEMICAL ADSORPTION

Sample Information

Method: Default
 Sample: 1 wt.% Pd on Alumina (75C)
 Operator: MM
 Submitter: JK
 Mass type: Calculated
 Empty tube: 22.3748 g
 Sample + tube: 23.4244 g
 Sample mass: 1.0496 g
 Density: 1.000 g/cm³
 Type of data: Automatically collected
 Instrument type: 2020chemi
 original instrument type: 2020chemi
 Comments:

Active Metals Table

Element	Atomic weight	Atomic Cross Sect Area (nm ²)	Density (g/cm ³)	Percent of Sample weight (%)		Percent Reduced Y	MxOy	MxOy
				(%)	X			
chromium	51.9960	0.0635	7.190	0.00	100.00	1	0	
	Adsorptive	Stoichiometry						
	Hydrogen	2.000						
	Oxygen	2.000						
cobalt	58.9330	0.0662	8.900	0.00	100.00	1	0	
	Adsorptive	Stoichiometry						
	Hydrogen	2.000						
	Oxygen	2.000						
copper	63.5400	0.0680	8.960	0.00	100.00	1	0	
	Adsorptive	Stoichiometry						
	Hydrogen	2.000						
	Oxygen	2.000						
molybdenum	95.9400	0.0730	10.220	0.00	100.00	1	0	
	Adsorptive	Stoichiometry						
	Hydrogen	2.000						
	Oxygen	2.000						
nickel	58.7100	0.0649	8.902	0.00	100.00	1	0	
	Adsorptive	Stoichiometry						
	Hydrogen	2.000						
	Oxygen	2.000						
palladium	106.4000	0.0787	12.020	1.00	100.00	1	0	
	Adsorptive	Stoichiometry						
	Hydrogen	2.000						
	Oxygen	2.000						
	Carbon Monoxide	1.000						

platinum	195.0900	0.0800	21.450	0.00	100.00	1	0
	Adsorptive	Stoichiometry					
	Hydrogen	2.000					
	Oxygen	2.000					
	Carbon Monoxide	1.000					
rhenium	186.2000	0.0649	21.020	0.00	100.00	1	0
	Adsorptive	Stoichiometry					
	Hydrogen	2.000					
	Oxygen	2.000					
	Carbon Monoxide	1.000					
rhodium	102.9050	0.0752	12.410	0.00	100.00	1	0
	Adsorptive	Stoichiometry					
	Hydrogen	2.000					
	Oxygen	2.000					
	Carbon Monoxide	1.000					
silver	107.8680	0.0869	10.500	0.00	100.00	1	0
	Adsorptive	Stoichiometry					
	Hydrogen	2.000					
	Oxygen	2.000					
	Carbon Monoxide	1.000					

Degas Conditions

Degas conditions: Degas Conditions

Evacuation Phase

Temperature ramp rate: 1.0 K/min
 Target temperature: 303 K
 Evacuation rate: 5.0 mmHg/s
 Unrest. evacuation from: 5.0 mmHg
 Vacuum level: 1.000000e-02 mmHg
 Evacuation time: 0 min

Heating Phase

Ramp rate: 1.0 K/min
 Hold temp: 303 K
 Hold time: 10 min

Evacuation and Heating Phases

Hold pressure: 100 mmHg

Backfill

Backfill sample tube: Yes

Analysis Conditions

```

Analysis conditions:      Paladium for Performance testing
Pre-analysis evacuation time: 0.50 h
Repeat analysis:        Yes
Repeat analysis evacuation time: 1.00 h
Equilibration time:     20
  
```

```

Adsorptive:              Hydrogen (H2)
Non-condensing adsorptive: No
Maximum manifold pressure: 925.00 mmHg
Molecular cross-sectional area: 0.123 nm2
Adsorbate molecular weight: 2.02
Thermal conductivity:    1.00
Non-ideality factor:     0.0000620
Density conversion factor: 0.0015468
  
```

Pressure Table

Starting Pressure (mmHg)	Pressure Increment (mmHg)	Ending Pressure (mmHg)
0.000000		1.000000
1.000000		2.000000
2.000000		3.000000
3.000000		4.000000
4.000000		5.000000
5.000000		6.000000
6.000000		7.000000
7.000000		8.000000
8.000000		9.000000
9.000000		10.000000
10.000000		20.000000
20.000000		30.000000
30.000000		40.000000
40.000000		50.000000
50.000000		60.000000
60.000000		70.000000
70.000000		80.000000
80.000000		90.000000
90.000000		100.000000
100.000000		125.000000
125.000000		150.000000
150.000000		175.000000
175.000000		200.000000
200.000000		225.000000
225.000000		250.000000
250.000000		275.000000
275.000000		300.000000
300.000000		325.000000
325.000000		350.000000
350.000000		375.000000
375.000000		400.000000
400.000000		425.000000
425.000000		450.000000
450.000000		475.000000
475.000000		500.000000

Preparation Options

Backfill and match transducer: Yes
Backfill gas: Helium
Fast evacuation: No
Unrestricted evac. from: 5.0 mmHg
Vacuum Level: 1.0e-02 mmHg
Evacuation time: 0.17 h

Analysis Task 1 - Evacuation

Backfill gas:
Evacuate for 10 min: below 10 µmHg.
Fast evacuation: No
Unrestricted evacuation pressure: 5.0 mmHg
Temperature: 373.1 K
Temperature rate: 10.0 K/min

Analysis Task 2 - Flow

Gas: Hydrogen
Time: 30 min
Temperature: 623.1 K
Temperature rate: 10.0 K/min
set external trigger: No

Analysis Task 3 - Evacuation

Backfill gas:
Evacuate for 180 min: below 10 µmHg.
Fast evacuation: No
Unrestricted evacuation pressure: 5.0 mmHg
Temperature: 648.1 K
Temperature rate: 10.0 K/min

Analysis Task 4 - Evacuation

Backfill gas:
Evacuate for 5 min: below 10 µmHg.
Fast evacuation: No
Unrestricted evacuation pressure: 5.0 mmHg
Temperature: 308.1 K
Temperature rate: 10.0 K/min

Analysis Task 5 - Leak Test

Outgas rate limit: 1.0e-02 mmHg/min
Temperature: 308.1 K
Temperature rate: 10.0 K/min

Free Space Options

Free space type: Measure after analysis
Estimated analysis free space: 0.0000 cm³

Temperature Options

Temperature control: Furnace
Analysis temperature: 348.1 K
Temperature rate: 10.0 K/min

Dosing Options

Absolute pressure tolerance: 5.000 mmHg
Relative pressure tolerance: 5.0 %
Low pressure incremental dose mode: Yes
Low pressure dose: 0.00045 mmol/g
Dose delay: 10 s

Termination Options

Backfill after analysis: Yes
Cool to < 50 °C: Yes

Report Options

Report options: Report Options
Show report title: Yes
Report title:
Show graphic: Yes
Graphic file: miclogo.emf
Graphic height: 0.250 in
Graphic width: 2.000 in
Use thermal transpiration correction: No

Isotherm: Yes

Tabular report selected: Yes
Plot report selected: Yes
X-axis scale: Logarithmic
Plot analysis: Yes
Plot repeat analysis: Yes

Isotherm Plot Options

Plot curve: Yes
Plot points: Yes
Overlay samples: Yes
Autoscale X axis: Yes
Autoscale Y axis: Yes

Difference Method: Yes

Summary report selected: Yes
Report analysis: Yes
Report repeat analysis: No
Report differences: Yes

Tabular report selected: Yes
Plot report selected: Yes
Plot analysis: Yes
Plot repeat analysis: Yes
Plot difference: Yes

Difference Plot options

Plot curve: Yes
Plot points: Yes
Overlay samples: No
Autoscale X axis: Yes
Autoscale Y axis: Yes

Sinfelt Method: No

Langmuir Surface Area: No

Freundlich: No

Temkin: No

Advanced Rpt.: No

Options: Yes

Sample Log: No

Manufacturing: No

Collected Data

Start time: 11/29/2014 3:23:19 AM
End time: 11/29/2014 11:38:28 PM
Unit number: 1
Serial number: 3003
Port: 2
Analysis temperature: 348.1 K
Measured free space: 14.9139 cm³
Free space time: 852 min

Collected Data Table

Run Time (min)	Pressure (mmHg)	Quantity Adsorbed (mmol/g)	Quantity Dosed (mmol/g)	Repeat analysis:			
				Run Time (min)	Pressure (mmHg)	Quantity Adsorbed (mmol/g)	Quantity Dosed (mmol/g)
30	0.002637	0.00090	0.00090				
35	0.003838	0.00178	0.00179				
41	0.004668	0.00267	0.00267				
46	0.005317	0.00355	0.00355				
52	0.005948	0.00443	0.00444				
57	0.006435	0.00531	0.00532				
62	0.007271	0.00619	0.00620				
68	0.008303	0.00708	0.00708				
74	0.009200	0.00795	0.00796				
79	0.010396	0.00883	0.00884				
85	0.011568	0.00971	0.00972				
91	0.012362	0.01059	0.01060				
97	0.013600	0.01146	0.01148				
104	0.014478	0.01234	0.01235				
109	0.033804	0.01315	0.01318				
115	0.090354	0.01380	0.01388				
121	0.193552	0.01431	0.01448				
126	0.340375	0.01469	0.01498				
131	0.535525	0.01501	0.01545				
139	0.836338	0.01533	0.01603				
145	1.052009	0.01550	0.01638				
278	6.241356	0.01687	0.02208	665	6.273385	0.00536	0.01059
278	6.241356	0.01687	0.02208				
278	6.241356	0.01687	0.02208				
278	6.241356	0.01687	0.02208				
278	6.241356	0.01687	0.02208				
				665	6.273385	0.00536	0.01059
				665	6.273385	0.00536	0.01059
				665	6.273385	0.00536	0.01059
				665	6.273385	0.00536	0.01059
				665	6.273385	0.00536	0.01059
282	7.484013	0.01711	0.02335	669	7.526332	0.00557	0.01185
286	8.541224	0.01728	0.02441	673	8.436768	0.00565	0.01269
289	9.848126	0.01744	0.02565	676	9.728883	0.00577	0.01389
293	10.917328	0.01756	0.02666	680	10.615537	0.00589	0.01475
298	19.890688	0.01811	0.03470	685	20.104963	0.00649	0.02326
302	28.752640	0.01865	0.04264	689	29.306334	0.00701	0.03145
306	38.015160	0.01914	0.05085	693	39.215008	0.00744	0.04015
310	48.783615	0.01970	0.06039	697	49.144562	0.00792	0.04892
314	58.990738	0.02022	0.06943	701	59.051441	0.00842	0.05768
318	68.679893	0.02077	0.07805	705	68.375412	0.00896	0.06600
322	78.915894	0.02145	0.08728	709	78.936531	0.00967	0.07552
326	89.067955	0.02247	0.09676	713	88.980087	0.01046	0.08468
330	98.893509	0.02365	0.10614	717	99.114769	0.01150	0.09417
335	125.573486	0.02631	0.13105	722	125.358635	0.01475	0.11931
340	147.873566	0.02836	0.15171	727	148.222244	0.01677	0.14041

340	147.873566	0.02836	0.15171	727	148.222244	0.01677	0.14041
344	172.599884	0.03015	0.17412	731	172.549377	0.01819	0.16212
348	197.348206	0.03122	0.19584	735	197.172211	0.01907	0.18354
352	222.420517	0.03185	0.21737	739	222.105453	0.01969	0.20496
356	247.266022	0.03230	0.23855	743	247.074768	0.02016	0.22625
360	272.295044	0.03259	0.25972	747	271.989532	0.02045	0.24733
364	296.974365	0.03324	0.28096	751	297.237274	0.02074	0.26867
368	321.808319	0.03456	0.30299	755	322.047058	0.02096	0.28959
372	347.283539	0.03452	0.32420	759	346.784119	0.02215	0.31141
376	372.285522	0.03431	0.34484	763	372.017487	0.02287	0.33318
380	397.179291	0.03435	0.36565	768	397.353577	0.02244	0.35388
385	422.055664	0.03470	0.38675	772	422.019257	0.02236	0.37438
389	447.089996	0.03474	0.40767	776	446.954742	0.02255	0.39537
393	471.972290	0.03502	0.42871	780	472.161102	0.02265	0.41650
397	496.971558	0.03504	0.44958	784	497.032837	0.02284	0.43743

Run Time (min)	Pressure (mmHg)	Quantity Adsorbed (mmol/g)	Repeat analysis: Pressure (mmHg)	Quantity Adsorbed (mmol/g)	Diff.	Sinf.	Lang.	Freu.	Temk.
30	0.002637	0.00090							
35	0.003838	0.00178							
41	0.004668	0.00267							
46	0.005317	0.00355							
52	0.005948	0.00443							
57	0.006435	0.00531							
62	0.007271	0.00619							
68	0.008303	0.00708							
74	0.009200	0.00795							
79	0.010396	0.00883							
85	0.011568	0.00971							
91	0.012362	0.01059							
97	0.013600	0.01146							
104	0.014478	0.01234							
109	0.033804	0.01315							
115	0.090354	0.01380							
121	0.193552	0.01431							
126	0.340375	0.01469							
131	0.535525	0.01501							
139	0.836338	0.01533							
145	1.052009	0.01550							
278	6.241356	0.01687	6.273385	0.00536					
278	6.241356	0.01687							
278	6.241356	0.01687							
278	6.241356	0.01687							
278	6.241356	0.01687							
278	6.241356	0.01687	6.273385	0.00536					
			6.273385	0.00536					
			6.273385	0.00536					
			6.273385	0.00536					
			6.273385	0.00536					
			6.273385	0.00536					

282	7.484013	0.01711	7.526332	0.00557
286	8.541224	0.01728	8.436768	0.00565
289	9.848126	0.01744	9.728883	0.00577
293	10.917328	0.01756	10.615537	0.00589
298	19.890688	0.01811	20.104963	0.00649
302	28.752640	0.01865	29.306334	0.00701
306	38.015160	0.01914	39.215008	0.00744
310	48.783615	0.01970	49.144562	0.00792
314	58.990738	0.02022	59.051441	0.00842
318	68.679893	0.02077	68.375412	0.00896
322	78.915894	0.02145	78.936531	0.00967
326	89.067955	0.02247	88.980087	0.01046
330	98.893509	0.02365	99.114769	0.01150
335	125.573486	0.02631	125.358635	0.01475
340	147.873566	0.02836	148.222244	0.01677
344	172.599884	0.03015	172.549377	0.01819
348	197.348206	0.03122	197.172211	0.01907
352	222.420517	0.03185	222.105453	0.01969
356	247.266022	0.03230	247.074768	0.02016
360	272.295044	0.03259	271.989532	0.02045
364	296.974365	0.03324	297.237274	0.02074
368	321.808319	0.03456	322.047058	0.02096
372	347.283539	0.03452	346.784119	0.02215
376	372.285522	0.03431	372.017487	0.02287
380	397.179291	0.03435	397.353577	0.02244
385	422.055664	0.03470	422.019257	0.02236
389	447.089996	0.03474	446.954742	0.02255
393	471.972290	0.03502	472.161102	0.02265
397	496.971558	0.03504	497.032837	0.02284

Experiment Log

Task Number	Task Name	Start Time (h:min)	Gas	Furnace Temp (K)	Sample Temp (min)	Time (mmHg)	Pressure
1	EVAC	0:02		311.9	314.8	10	
2	EVAC	0:18		375.6	373.4	10	
3	FLOW	0:34	H2	615.5	623.1	30	884.224182
4	EVAC	1:25		637.8	647.7	180	
5	EVAC	4:31		304.9	308.5	5	
6	LEAK	5:09		304.9	308.3	1	0.009992
7	EVAC	5:13		350.6	348.4	30	

Leak Test Results

Start Time (h:min)	Maximum Allowed Outgas Rate (mmHg/min)	Observed Outgas Rate (mmHg/min)	Status
5:13	1.0e02	3.0e04	Pass

Sample log

Date Time Log Message

11/27/2014	9:55:02 AM	Analysis on file C:\ASAP 2020 Chemi Plus\data\p
11/27/2014	9:55:11 AM	A sample analysis for C:\ASAP 2020 Chemi Plus\d
11/27/2014	9:55:17 AM	A sample analysis for C:\ASAP 2020 Chemi Plus\d
11/27/2014	9:55:20 AM	A sample analysis for C:\ASAP 2020 Chemi Plus\d
11/27/2014	9:55:29 AM	A sample analysis for C:\ASAP 2020 Chemi Plus\d
11/27/2014	9:55:34 AM	A sample analysis for C:\ASAP 2020 Chemi Plus\d
11/27/2014	9:55:37 AM	A sample analysis for C:\ASAP 2020 Chemi Plus\d
11/27/2014	9:55:40 AM	A sample analysis for C:\ASAP 2020 Chemi Plus\d
11/27/2014	9:55:43 AM	A sample analysis for C:\ASAP 2020 Chemi Plus\d
11/27/2014	9:55:48 AM	A sample analysis for C:\ASAP 2020 Chemi Plus\d
11/27/2014	9:55:54 AM	Manual: close valve 6.
11/27/2014	9:56:04 AM	A sample analysis for C:\ASAP 2020 Chemi Plus\d
11/27/2014	9:56:53 AM	Analysis on file C:\ASAP 2020 Chemi Plus\data\p
11/29/2014	3:23:19 AM	Analysis on file C:\ASAP 2020 Chemi Plus\data\p
11/29/2014	11:38:28 PM	Analysis on file C:\ASAP 2020 Chemi Plus\data\p

H FLOWMETER CONVERSION FACTORS FOR CHEMICAL ADSORPTION

The gas flowmeter on the front panel displays the gas flow rate for air in standard cubic centimeters per minute (sccm). To obtain the actual flow rate for gases other than air, divide the displayed gas flow rate by a conversion factor from the following table:

Example 1:

Oxygen is flowing through the meter at a displayed rate of 30 sccm (air). The actual flow rate is:
 $30 \div 1.05 = 28.6$ sccm

Example 2:

You require a helium flow rate of 40 sccm. In this case, multiply the required flow rate by the conversion factor: $40 \times 0.37 = 14.8$ sccm (air).

Adjust the gas flow until the gas flowmeter displays 14.8 sccm.

Flowmeter Conversion Factors

Gas	Factor
Air	1.00
Argon	1.18
Butane	1.42
Carbon dioxide	1.23
Carbon monoxide	0.98
Cyclopropane	1.21
Ethane	1.02
Helium	0.37
Hydrogen	0.26
Isobutane	1.42
Methane (natural gas)	0.75
Neon	0.83
Nitrogen	0.98
Nitrous oxide	1.23
Oxygen	1.05
Propane	1.23
Sulfur hexafluoride	2.25

Blank Page

I ADVANCED REPORTS - PYTHON MODULE



See also:

[MicModule Python Calls on page I - 17](#)

- **Summary reports.** Consist of summary sections, each containing a two-column table of label and value pairs. Summary reports are created with the *mic.summary* call.
- **Tabular reports.** Consist of one or more tables each containing one or more labeled columns of data. Tabular reports are created with the *mic.table* call.
- **Graphical reports.** Consist of a single graph with one or more curves on one or two y-axes. Graphical reports are created with the *mic.graph* call.

Calls for accessing the sample file data can be found in the *Mic Module Python Calls* section of this appendix. More advanced example python scripts are included in the analyzer software. Application specific discussions can be found on <http://www.micro-report.com>



The examples in this topic are also included as a part of the Micromeritics installation process and are located in the *Scripts* sub-directory.

ADVANCED REPORT OPTIONS

Up to five Advanced reports, each with up to 10 summary reports, 10 tabular reports, and 10 graphical reports can be created. To use this feature, a file containing a Python script that imports a "mic" Python module must be created. See [MicModule Python Calls on page I - 17](#) for an example of Python script and functions for the "mic" Python module.

1. Create the Python script and save it in the *Scripts* directory.
2. Open a sample file with a *Complete* status.
3. Select *Advanced* in the drop-down list at the bottom of the window to return to the tabbed view.
4. On the *Report Options* tab, select *Advanced Rpt.* (or *User-Defined*) in the *Selected Reports* list box, then click **Edit**.
5. On the *Advanced Report Options* window, click **Add** in the *Available Scripts* group box to locate and select the Python script. Repeat for each script to be added.

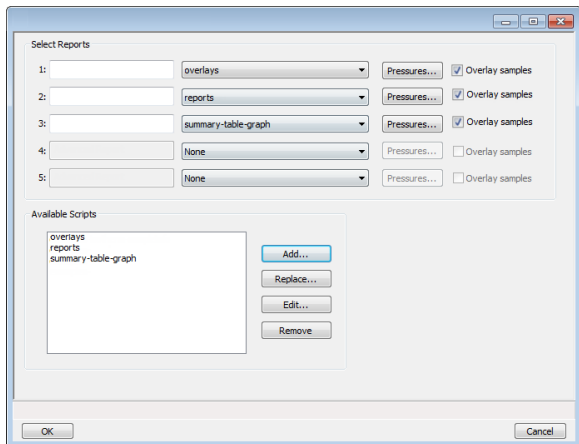

6. In the *Selected Reports* group box, click the drop-down arrows to select up to five Python scripts previously added in the *Available Scripts* box.
7. On the *Report Options* tab, click **Preview**. The Python Reports will be included on the tabs across the top portion of the *Reports* window.

Advanced Reports

Field or Button	Description
Add [button]	Click to add additional Python reports.
Advanced Report 1 through 5 [drop-down box]	Use the drop-down lists to select currently-defined functions used to define the report calculations and output.
Available Scripts [group box]	Lists the available reports and provides the option to add, replace, edit, or remove reports.
Overlay samples (if shown) [checkbox]	Use to overlay samples as defined by the function.



For fields and buttons not listed in this table, see [Common Fields and Buttons on page 2 - 3](#).

SCRIPTS

Run a Script

1. Open a sample file with a *Complete* file status.
2. Select *Advanced* in the drop-down list at the bottom of the window.
3. Select the *Report Options* tab.
4. Highlight *Advanced* in the *Reports* list box, then click **Edit**.
5. On the *Advanced Report Options* window, click **Add**. Locate and select one or more python scripts then click **Select**. The selected scripts become a part of the drop-down list in the *Available Scripts* section of the *Advanced Report Options* window.
6. In the *Selected Reports* section, select up to five Advanced reports in the drop-down lists. Use the **Pressures** button to include or exclude available pressures in the report.
7. Click **OK**.
8. Click **Preview** on the *Report Options* tab to view all reports selected in the previous window.

Remove a Script

Select the script in the *Available Scripts* box then click **Remove**. The script is removed from the application however, the original .py text file is not affected.

Edit a Script



When a script is added, the code is stored within the application. If the script changes outside of the application, the script file will have to be re-added to the Advanced Report Options window for the changes to take affect.

Field or Button	Description
Add [button]	Adds one or more scripts to the <i>Available Scripts</i> box. The added scripts then become available as options in the <i>Selected Reports</i> section.
Edit [button]	Edits the script stored within the application but does not affect the original .py text file.
Overlay samples [checkbox]	Select to enable the overlay sample files process.
Pressures [button]	Select to include or exclude pressures from the report. <ul style="list-style-type: none"> • Calculation pressure range. Enter the minimum and maximum pressures to be used in the pressure table. • Cancel. Discards any changes or cancels the current process. • Exclude All. Select to exclude all pressure points in the table. • Include All. Select to include all pressure points in the table. • OK. Saves and closes the active window.
Remove [button]	Removes the script from the <i>Available Scripts</i> box but does not affect original .py text file.
Replace [button]	Replaces the contents of the selected script however, the script name remains the same.

PYTHON REPORTS

Graphic Report

This script is an example of the mic module producing a graph with two curves:

```
import mic
import numpy as np

mic.graph( 'My Graph', 'x', 'f(x)' )

myx = np.array( [0.1, 0.2, 0.3, 0.4, 0.5, 0.6, 0.7, 0.8, 0.9, 1.0 ] )
mic.graph.add( 'x^2', myx, myx*myx, marker='o' )
mic.graph.add( 'sin(x)', myx, np.sin(myx), marker='^' )
```

The results are:

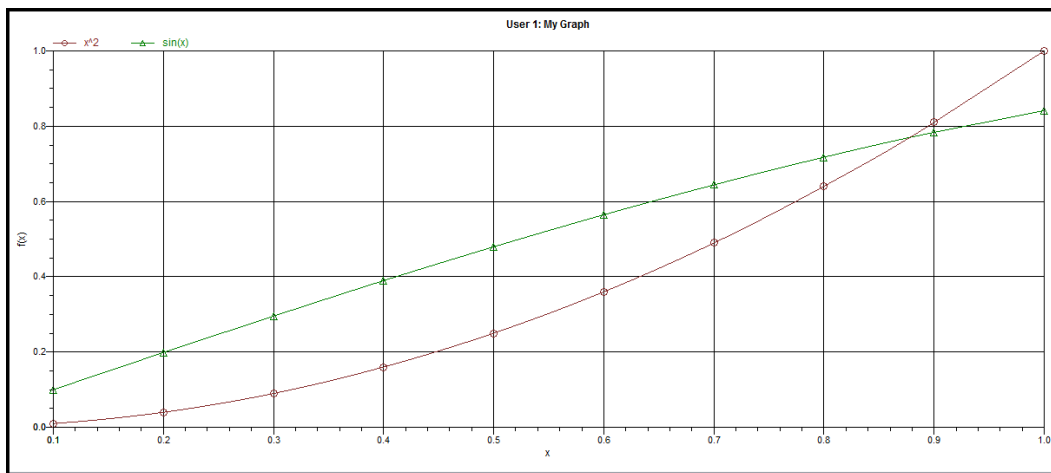

Summary Report

This script produces a summary report with two summaries:

```
import mic
mic.summary( "My Summaries" )

mic.summary.add( "Summary A",
                ["label 1:", "label 2:", "label 3:"],
                ["val1", "val2", "val3"] )

mic.summary.add( "Summary B",
                ["label 4:", "label 5:", "label 6:"],
                ["val4", "val5", "val6"] )
```

The result is:

```
Summary A
label 1: val1
label 2: val2
label 3: val3

Summary B
label 4: val4
label 5: val5
label 6: val6
```

Tabular Report

If more than one column is required, the call *mic.table* is employed. This script produces a tabular report consisting of two tables. **NOTE:** This script uses the Python package "numpy" and c-style formatting of the numerical values.

```
import mic
import numpy as np

mic.table("My Tables")

mic.table.addtable( "My set A" )
mic.table.addcolumn( "x", ["1.0", "2.0", "3.0"] )
mic.table.addcolumn( "y", ["0.5", "1.0", "1.5"] )

x1 = 0.2
x2 = 0.5
x3 = 3.14159/2
mic.table.addtable( "My set B" )
mic.table.addcolumn( "x", ["%8.3f" % x1,
                          "%8.3f" % x2,
                          "%8.3f" % x3 ] )

mic.table.addcolumn( "sin(x)", ["%8.3f" % np.sin(x1),
                               "%8.3f" % np.sin(x2),
                               "%8.3f" % np.sin(x3)] )

mic.table.addcolumn( "cos(x)", ["%8.3f" % np.cos(x1),
                               "%8.3f" % np.cos(x2),
                               "%8.3f" % np.cos(x3)] )
```

The result is:

My set A		
x	y	
1.0	0.5	
2.0	1.0	
3.0	1.5	

My set B		
x	sin(x)	cos(x)
0.200	0.199	0.980
0.500	0.479	0.878
1.571	1.000	0.000

ACQUIRE BASIC INFORMATION

Physisorption

To acquire the adsorption isotherm and other basic information about the sample being edited, the calls *mic.isotherm*, *mic.sample_information*, and *mic.adsorptive_data* are applied.

This script produces a graph of the adsorption and desorption isotherms for both relative and absolute pressure, and prints summaries of the sample information and the adsorptive properties.

```
import mic

prel, qads, n_ads, ambient_fs, analysis_fs, mass, desc = mic.isotherm('rel')
mic.graph( 'Graphical Report 1', 'Rel. Press', 'Quantity Adsorbed' )
mic.graph.add( 'Sample isotherm', prel, qads )

pabs, qads, n_ads, ambient_fs, analysis_fs, mass, desc = mic.isotherm('abs')

mic.graph( 'Graphical Report 2' 'Abs. Press', 'Quantity Adsorbed')
mic.graph.add('Sample Isotherm', pabs, qads)

mass = mic.sample_information('sample mass' )
Tanl = mic.sample_information('analysis temperature' )
dens = mic.sample_information('sample density')

mic.summary( "Sample Information" )
mic.summary.add( "Sample Information:",
                [ "Number of adsorption points:",
                  "Ambient Free space:",
                  "AnalysisFree space:" ,
                  "Sample mass (g):",
                  "Description:",
                  "Analysis Temp:",
                  "Sample Density (g/cm^3):" ],
                [ "%8.3f" % n_ads,
                  "%8.3f" % ambient_fs,
                  "%8.3f" % analysis_fs,
                  "%8.3f" % mass,
                  desc,
                  "%8.3f" % Tanl,
                  "%8.3f" % dens ] )

csa, hsd, dcf, mol_weight, analysis_gas = mic.adsorptive_data()

mic.summary.add( "Adsorptive Data",
                [ "Cross Sectional Area",
```



```

    "Hard Sphere Diameter",
    "Density Conversion Factor",
    "Molecular Weight",
    "Analysis gas"],
  [ "%8.3f" % csa,
    "%8.3f" % hsd,
    "%8.3f" % dcf,
    "%8.3f" % mol_weight,
    analysis_gas ] )

```

Note the calls to *mic.isotherm* and *mic.adsorptive_data* above are each returning results as a list with elements of varying return type.

Chemisorption

This script produces a graph of the primary, repeat, and difference isotherms, and prints summaries of the sample information and the adsorptive properties.

To acquire the adsorption isotherm and other basic information about the sample being edited, the calls *mic_chem.isotherm*, *mic.sample_information*, and *mic.adsorptive_data* are applied.

Note the calls to *mic_chem.isotherm* and *mic.adsorptive_data* above are each returning results as a list with elements of varying return type.

```

import mic

p_primary,    q_primary    = mic.chem_isotherm('primary')
p_repeat,    q_repeat    = mic.chem_isotherm('repeat')
p_difference, q_difference = mic.chem_isotherm('difference')
mic.graph( 'Graphical Report 1', 'Abs. Press', 'Quantity Adsorbed')
mic.graph.add('Primary', p_primary    , q_primary)
mic.graph.add('Repeat', p_repeat    , q_repeat)
mic.graph.add('Difference', p_difference, q_difference)

mic.summary( "Sample Information" )
mic.summary.add( "Sample Information:",
  [ "Ambient Free space (cm^3):",
    "Analysis Free space (cm^3):" ,
    "Sample mass (g):",
    "Description:",
    "Analysis Temp (K):",
    "Sample Density (g/cm^3):" ],
  [ "%8.3f" % mic.sample_information('ambient freespace'),
    "%8.3f" % mic.sample_information('analysis freespace'),
    "%8.3f" % mic.sample_information('sample mass'),
    mic.sample_information('sample description'),
    "%8.3f" % mic.sample_information('analysis temperature'),

```

```
        "%8.3f" % mic.sample_information('sample density') ] )  
  
csa, hsd, dcf, mol_weight, analysis_gas = mic.adsorptive_data()  
  
mic.summary.add( "Adsorptive Data",  
                [ "Cross Sectional Area",  
                  "Hard Sphere Diameter",  
                  "Density Conversion Factor",  
                  "Molecular Weight",  
                  "Analysis gas"],  
                [ "%8.3f" % csa,  
                  "%8.3f" % hsd,  
                  "%8.3f" % dcf,  
                  "%8.3f" % mol_weight,  
                  analysis_gas ] )
```

ACQUIRE REPORT RESULTS

Sample file report results may be accessed using the *mic.report* call. This script prints a summary of the results of the *t*-plot and BET reports.

```
import mic

sa = mic.report("bet", "surface area")
c = mic.report("bet", "bet constant")
vm = mic.report("bet", "monolayer capacity")
esa = mic.report("tplot", "external surface area")
vol = mic.report("tplot", "micropore volume")

mic.summary( "BET and T-plot Results" )

mic.summary.add( "Report Results",
    [ "bet surface area",
      "bet constant",
      "bety 6" ,
      "tplot external surface area",
      "tplot micropore volume"],
    [ "%10.5f" % sa,
      "%10.5f" % c,
      "%10.5f" % vm,
      "%10.5f" % esa,
      "%10.5f" % vol ] )
```

The result is:

Report Results	
bet surface area	796.36286
bet constant	137786.85871
bet monolayer capacity	182.96348
tplot external surface area	416.38843
tplot micropore volume	0.17931

Acquiring the results from a pore-distribution report such as the BJH method is done in a similar way as in the previous script except the return values from the *mic.report* call are slightly different since they involve lists of data. For example,

```
import mic
xdat, ydat, desc = mic.report('bjhads', 'incremental distribution' )
mic.graph( 'BJH Ads/Des', 'Pore diameter', 'Incremental Volume' )
mic.graph.add( desc, xdat, ydat )
```

The result is:

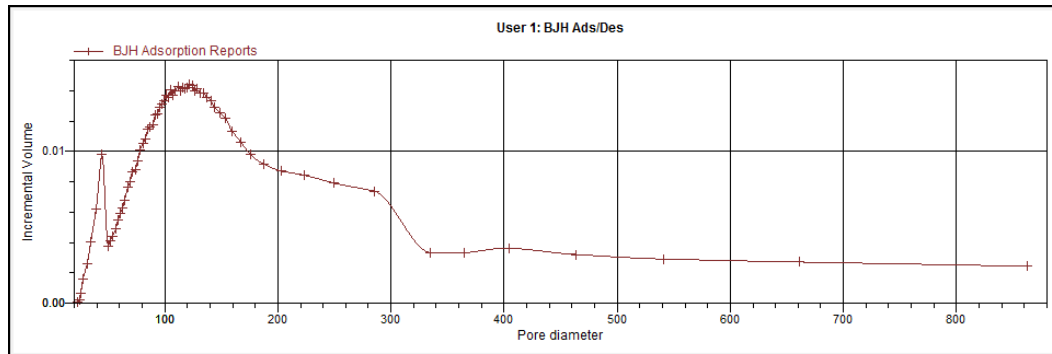

See the *Mic Module Python Calls* section for a more complete description of the usage and scope of the *mic.report* call.

ACQUIRE OVERLAY SAMPLE DATA

Physisorption

The call to obtain overlay sample data is similar to the calls for the primary sample. This script involves two overlay sample files.

The calls to obtain adsorptive data and report results for an overlay sample file using *mic.report* and *mic.adsorptive_data* have a very similar interface as the *mic.overlay call*, and a summary of their usage is shown in the example in this topic.

```
import mic

p, q, n, fsw, fsc, mass, desc = mic.isotherm('rel')
p1, q1, n1, fsw1, fsc1, mass1, desc1 = mic.overlay( 1, 'rel')
p2, q2, n2, fsw2, fsc2, mass2, desc2 = mic.overlay( 2, 'rel')

mic.graph( 'Three Sample Isotherms',
          'Rel. Press',
          'Quantity Adsorbed (cm^3/g)' )

mic.graph.add( 'Primary Isotherm ', p, q )
mic.graph.add( 'Overlay Isotherm 1', p1, q1 )
mic.graph.add( 'Overlay Isotherm 2', p2, q2 )

mic.summary( "A summary report" )

mic.summary.add( "Two samples",
                [ "Primary Sample:",
                  "Overlay Sample 1:",
                  "Overlay Sample 2:" ],
                [ desc,
                  desc1,
                  desc2] )
```

The results are:

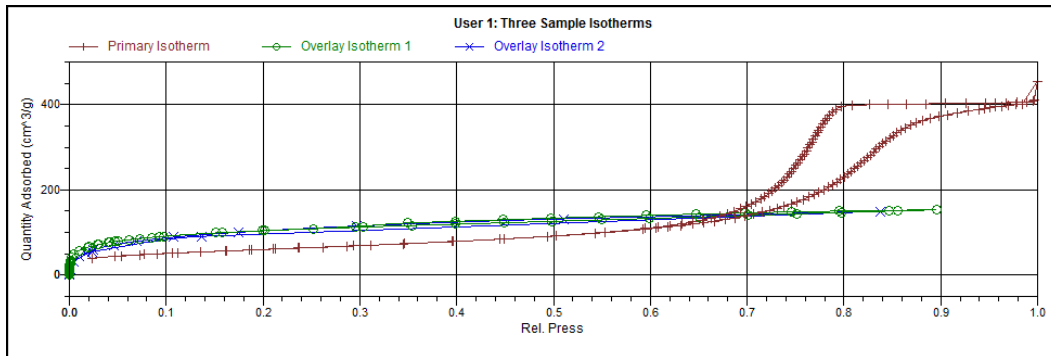

Two samples
 Primary Sample: 12 mm Tube N2 Silica-Alumina ADS-DES with FS
 Overlay Sample 1: Activated Carbon Hexane Dosed from Port 3 - 2
 Overlay Sample 2: Activated Carbon Tube C4 Butane Port 3

To enable the use of overlay data in the Advanced reports, the following two actions must be taken prior to running the script:

- Sample files to overlay must be selected, and
- The *Overlay samples* checkbox on the *Advanced Report Options* window must be selected

Chemisorption

The call to obtain overlay sample data is similar to the calls for the primary sample. This script involves two overlay sample files.

The calls to obtain adsorptive data and report results for an overlay sample file using *mic.report* and *mic.adsorptive_data* have a very similar interface as the *mic.chem.overlay* call, and a summary of their usage is shown in the example in this topic.

```
import mic

p0, q0 = mic.chem_isotherm('primary')
p0r, q0r = mic.chem_isotherm('repeat')
p1, q1 = mic.chem_overlay(1, 'primary')
p1r, q1r = mic.chem_overlay(1, 'repeat')
p2, q2 = mic.chem_overlay(2, 'primary')
p2r, q2r = mic.chem_overlay(2, 'repeat')
mic.graph( 'Graphical Report 1', 'Abs. Press', 'Quantity Adsorbed')
mic.graph.add('prim 0', p0, q0)
mic.graph.add('rep 0', p0r, q0r)
mic.graph.add('prim 1', p1, q1)
mic.graph.add('rep 1', p1r, q1r)
mic.graph.add('prim 2', p2, q2)
mic.graph.add('rep 2', p2r, q2r)

mic.summary( "A summary report" )

mic.summary.add( "Sample and Two Overlays",
  [ "Primary Sample:",
    "Overlay Sample 1:",
    "Overlay Sample 2:" ],
  [ mic.sample_information('sample description'),
    mic.sample_information('sample description',1),
    mic.sample_information('sample description',2) ] )
```

ENABLE THE USE OF OVERLAY DATA

1. On the *Report Options* tab, click **Overlays**.
2. On the *Plot Overlay Sample Selection* window, to move a file from the *Available Files* list box to the *Selected Files* list box, either double click a file name in the *Available Files* list box or click one or more files in the *Available Files* list box then click **Add**.

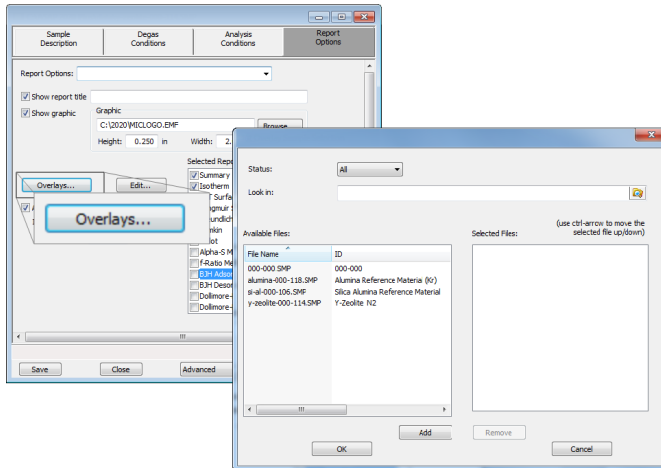

3. Click **OK**.
4. On the *Report Options* tab, highlight *Advanced* in the *Selected Reports* list box.
5. Click **Edit** to the left of the *Selected Reports* list box.
6. Select the *Overlay samples* checkbox to the right of the selected report.
7. Click **OK**.
8. Run the script using the instructions found in [Scripts on page I - 3](#).

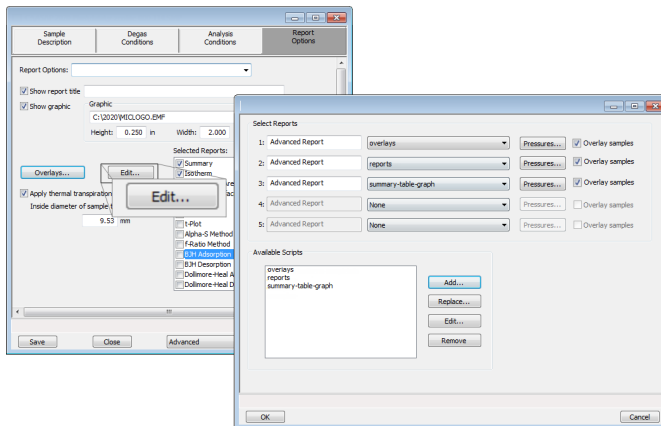

MICMODULE PYTHON CALLS

TABLES

Available Mic Python calls for tables:

- Create a new tabular report
- Add a column
- Add a table

Add a Table

This script adds a table to the last created tabular report:

```
mic.table.addtable( name )
```

Keyword arguments:

```
name --- the table name
```

Add a Column

This script adds a column to the last created table:

```
mic.table.addcolumn( header, values )
```

Keyword arguments:

```
header --- column header; must be a string (or convertible)  
values --- column values; must be a list of strings (or convertible)
```

Create a New Tabular Report

```
mic.table( title='User Table' )
```

Keyword arguments:

```
title --- the tabular report title (default = 'User Table')
```

SUMMARY REPORTS



See also:

[*Python Reports on page I - 5*](#)

Add a Summary Section

This script adds a summary section to the last created summary report:

```
mic.summary.add( name, labels, values )
```

Keyword arguments:

```
name    --- summary section name
labels  --- column of labels; must be a list of strings
         (or convertible) and the same length as values
values  --- column of values; must be a list of strings
         (or convertible) and the same length as labels
```

Create a New Summary Report

```
mic.summary( title='User Summary' )
```

Keyword arguments:

```
title  --- the summary title
```

GRAPHIC REPORTS



See also:

[Python Reports on page I - 5](#)

Add a Curve

This script adds a curve to the last created graphical report:

```
mic.graph.add( name, x, y, yyaxis=False, color=None, linestyle='-', marker='a', graphtype='both' )
```

Keyword arguments:

```

name      --- the curve name
x         --- list of x values; must be a list of floats
           (or convertible) and the same length as y
y         --- list of y values; must be a list of floats
           (or convertible) and the same length as x
yyaxis    --- place this curve on the yy-axis if True
           otherwise place on the y-axis (default = False)
color     --- RGB color as an HTML hex string (e.g., '#4169e1')
           or a three-element list or tuple (e.g., [65,105,225]);
           if None, color is automatically selected (default = None)
linestyle --- line style; (default = '-')
           '-'      : solid
           '--'     : dash
           '.'      : dot
           '-.'     : dash dot
           '-..'    : dash dot dot
marker    --- marker shape; (default = 'a')
           '+'      : plus
           'o' or '0' : circle
           'x'      : cross
           '^'      : up triangle
           'v'      : down triangle
           's'      : square
           'd'      : diamond
           '8'      : hourglass
           '~'      : horizontal hourglass
           '' or None : no marker
           'a'      : automatically selected
graphtype --- graph type; (default = 'both')
           'curve' or 'c' : curve
    
```

```
'points' or 'p' : points  
'both'   or 'b' : curve-and-points  
'hist'   or 'h' : histogram
```

Add a Curve Using the Second Y-Axis

This script adds a curve to the last created graphical report using the second y-axis:

```
mic.graph.addyy( name, xx, yy )
```

Add a curve to the last created graphical report using the second y-axis. The arguments to this call are the same as to mic.graph.add with the argument

Create a New Graphical Report

```
mic.graph( title='User Graph', xlabel='X axis', ylabel='Y axis', ylabel='YY axis', xlinear=True, ylinear=True, yylinear=True )
```

Keyword arguments:

```
title      --- the graphical report title (default = 'User Graph')  
xlabel     --- x-axis label (default = 'X axis')  
ylabel     --- y-axis label (default = 'Y axis')  
ylabel     --- yy-axis label (default = 'YY axis')  
xlinear    --- x-axis linear scale; if false, use log scale  
            (default = True)  
ylinear    --- y-axis linear scale; if false, use log scale  
            (default = True)  
yylinear   --- yy-axis linear scale; if false, use log scale  
            (default = True)
```

GET PRIMARY ISOTHERM DATA

```
mic.overlay( overlay_number = 1, press_type='rel' )
```

Keyword arguments:

```
overlay_number --- the overlay number (1 through 8; default = 1)
press_type      --- the pressure basis; use 'rel' for relative pressure,
                  'abs' for absolute (default = 'rel')
```

Usage:

```
p, qads, num_ads, ambient_fs, analysis_fs, mass, desc = mic.overlay(1,
'rel')
```

```
p          --- array of pressure (relative or absolute);
              empty-array if overlay is unavailable
qads       --- array of cumulative quantity adsorbed;
              empty-array if overlay is unavailable
num_ads    --- number of points in the adsorption curve;
              0 if overlay is unavailable
ambient_fs --- ambient free-space; 0.0 if overlay is unavailable
analysis_fs --- analysis free-space; 0.0 if overlay is unavailable
mass       --- sample mass; 0.0 if overlay is unavailable
desc      --- sample description; empty-string if
              overlay is unavailable
```

Chemisorption

```
mic.chem_isotherm( branch='primary' ) :
```

Get primary, repeat and difference isotherm data.

Keyword arguments:

```
branch --- Specifies which analysis to get isotherm data;
          use 'primary' for the first analysis,
          'repeat' for the repeat analysis
          and 'difference' for the difference of these two
```

Usage:

```
p, q = mic.chem_isotherm('primary')
p, q = mic.chem_isotherm('repeat')
p, q = mic.chem_isotherm('difference')
p     --- array of absolute pressures
q     --- array of cumulative quantity adsorbed
```

GET OVERLAY ISOTHERM DATA

Physisorption

```
mic.overlay( overlay_number = 1, press_type='rel' )
```

Keyword arguments:

```
overlay_number --- the overlay number (1 through 8; default = 1)
press_type     --- the pressure basis; use 'rel' for relative pressure,
                  'abs' for absolute (default = 'rel')
```

Usage:

```
p, qads, num_ads, ambient_fs, analysis_fs, mass, desc = mic.overlay(1,
'rel')
```

```
p          --- array of pressure (relative or absolute);
              empty-array if overlay is unavailable
qads       --- array of cumulative quantity adsorbed;
              empty-array if overlay is unavailable
num_ads    --- number of points in the adsorption curve;
              0 if overlay is unavailable
ambient_fs --- ambient free-space; 0.0 if overlay is unavailable
analysis_fs --- analysis free-space; 0.0 if overlay is unavailable
mass       --- sample mass; 0.0 if overlay is unavailable
desc       --- sample description; empty-string if
              overlay is unavailable
```

Chemisorption

```
mic chem_overlay( overlay_number = 1, branch='primary' ) :
```

Get overlay isotherm data.

Keyword arguments:

```
overlay_number --- the overlay number (1 through 8; default = 1)

branch --- Specifies which analysis to get isotherm data;
          use 'primary' for the first analysis,
          'repeat' for the repeat analysis
          and 'difference' for the difference of these two
```

Usage:

```
p, q = mic.chem_overlay(1, 'primary')
p, q = mic.chem_overlay(1, 'repeat')
p, q = mic.chem_overlay(1, 'difference')
p    --- array of absolute pressures
q    --- array of cumulative quantity adsorbed
```

GET ADSORPTIVE DATA FOR EACH SAMPLE

```
mic.adsorptive_data( sample_number = 0 )
```

Keyword arguments:

```
sample_number --- Identifier for the adsorptive data to retrieve
0              : the current sample file
1 through 8   : the corresponding overlay sample file
```

Usage:

```
csa, hsd, dcf, mol_weight, analysis_gas = mic.adsorptive_data()
csa, hsd, dcf, mol_weight, analysis_gas = mic.adsorptive_data(0)
```

```
csa          --- cross sectional area (nm^2)
hsd          --- hard sphere diameter (angstroms)
dcf          --- density conversion factor (dimensionless)
mol_weight   --- molecular weight
analysis_gas --- mnemonic for the analysis gas species
              (e.g., 'CO', 'H2')
```

GET SAMPLE INFORMATION ITEM

```
mic.sample_information( item, sample_number = 0 )
```

Keyword arguments:

```
item          --- string identifying the item to be returned.
                Accepted identifiers are

                'sample mass'
                'sample description'
                'analysis temperature' (degrees Kelvin)
                'sample density'      ( g/cm^3 )

sample_number --- Sample to retrieve (default = 0).
0              : the current sample file
1 through 8   : the corresponding overlay sample file
```

Usage:

```
mass = sample_information('sample mass')
mass = sample_information('sample mass',0)
```

GET REPORT RESULTS FOR PHYSICAL ADSORPTION

This script gets report results for the indicted report and sample:

```
mic.report( report_name, result, sample_number = 0 )
```

Keyword arguments:

```
sample_number --- Identifier for the sample data to retrieve
                  0           : the current sample file
                  1 through 8 : the corresponding overlay sample file
```

Usage:

```
sa = mic.report( 'bet' , 'surface area' )
porewidth, incvol, desc = mic.report( 'bjhads' ,
                                     'incremental distribution' )
```

The available report keywords, result keywords and a corresponding description of the result is listed in the table below:

Report keyword	Result keyword	Description
-----	-----	-----
bet	surface area	Surface area (m ² /g)
bet	bet constant	BET constant (dimensionless)
bet	monolayer capacity	Monolayer capacity (cm ³ /g)
tplot	external surface area	External surface area (m ² /g)
tplot	micropore volume	Micropore volume (cm ³ /g)
bjhads	incremental distribution	Incremental Distribution
bjhdes	incremental distribution	Incremental Distribution
dhads	incremental distribution	Incremental Distribution
hk	incremental distribution	Incremental Distribution
dft	incremental distribution	Incremental Distribution
nldft	incremental distribution	Incremental Distribution

where the incremental pore distribution result above (for those reports which return this) is a list with three components being,

```
porewidth --- array of pore dimension boundaries (angstroms);
              empty-array if unavailable.
incvol      --- array of incremental pore volumes (cm3/g);
              empty-array if unavailable.
desc       --- Name of data set; empty-string if unavailable.
```

GET IMPORTED PORE DATA

```
mic.imported_pore_data( import_number = 1 )
```

Keyword arguments:

```
import_number --- the import number (1 through 8)
```

Usage:

```
xdat, ydat, desc = mic.imported_pore_data(1)
```

```
xdat --- array of pore dimension boundaries (angstroms);  
empty-array if unavailable.
```

```
ydat --- array of incremental pore volumes (cm3/g);  
empty-array if unavailable.
```

```
desc --- Name of data set; empty-string if unavailable.
```

GET METAL COMPOSITION FOR CHEMICAL ADSORPTION

```
mic metal_composition( metal='', metal_property='', sample_number = 0 ) :
```

Get information about the active metals in this sample

Keyword arguments:

```
metal          --- the metal to return information about
                  if '' or None, then return a list of the
                  active metals

metal_property --- the specific property to return information on
                  if '' or None, then return all the properties
                  for the specified metal (requires metal to be
                  specified)

sample_number --- Identifier for the metal data to retrieve
                  0           : current sample file (default)
                  1 through 8 : corresponding overlay sample file
```

Usage:

```
metal_list = mic.metal_composition()
copper_prop = mic.metal_composition( 'copper' )
copper_perc = mic.metal_composition( 'copper',
                                     'percent of sample mass' )
```

In the above first usage case, the list of active metals is returned. In the above second usage case, a python dictionary type is returned which includes all the properties of the metal available and their corresponding values. The last case returns a single value (int, float, or string) for the specified property.

The metal_property keywords which one can use are

```
atomic weight
oxygen atoms
density
percent of sample mass
metal atoms
cross sectional area
percent reduced
stoichiometry H2
stoichiometry O2
stoichiometry He
```

Or as just mentioned, one can make the call
`metal_composition(metalname)` without any `metal_property`
keyword provided to see the whole dictionary.

J VAPOR ADSORPTION OPTION

The Vapor Adsorption Option uses vapors as the adsorbent when the sample is near or above room temperature. The analysis system is heated to approximately 45 °C and the vapor source to approximately 40 °C, which allows analyses at up to 35 °C.

The Vapor Adsorption option consists of a vapor enclosure, heated manifold cover, temperature controller, and vapor source tube.



Water Vapor Controller



Temperature Controller

VAPOR ENCLOSURE

The vapor enclosure houses the vapor tube. Its temperature is regulated by the temperature controller. The door to the vapor enclosure should remain closed while the instrument is in operation.

TEMPERATURE CONTROLLER

The front panel of the temperature controller has a display for the vapor source and a separate display for the manifold.

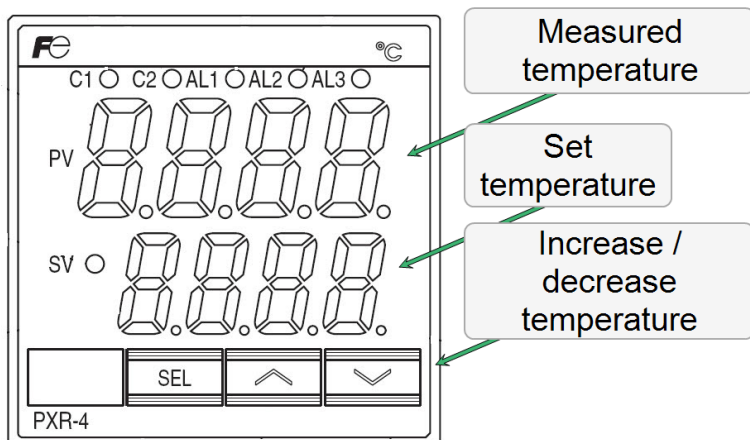

Upon installation, the temperature of the vapor source is set at 40 °C (for analysis temperatures up to 35 °C). The analysis manifold is set between 55 and 60 °C to achieve a 45 - 47 °C manifold temperature (displayed on the instrument schematic).

Use the **Up** and **Down** arrow keys to adjust the temperature.

ANALYSIS MANIFOLD



Do not adjust the temperature of the manifold. The manifold temperature has been set and calibrated to 45 °C and is suitable for any type of analysis. If the manifold temperature is changed, recalibration by a Micromeritics Service Representative is required.

The manifold temperature displayed on the schematic will differ from the temperature displayed on the temperature controller. A difference of 10 °C to 15 °C is typical. The schematic reading reflects the true manifold temperature and is the one used in calculations.

VAPOR SOURCE

For analysis temperatures up to 35 °C, the recommended temperature for the vapor source is 40 °C. For analysis temperatures over 35 °C, use the **Up** and **Down** buttons to adjust the temperature of the vapor source to a value that is midway between the manifold temperature and the analysis temperature. For example, to perform analyses at 40 °C and the manifold temperature displayed on the instrument schematic is 45 °C, adjust the vapor enclosure temperature to 42.5 °C.

VAPOR TUBE

The vapor tube contains the vapor source and is installed inside the vapor enclosure.

VAPOR ANALYSIS

When running vapor analyses, it is important to:

- Remove the cold trap dewar to prevent vapor from freezing in the cold trap.
- Thoroughly degas the vapor source. See [Degas the Vapor Source Tube on page J - 10](#).
- Use the metal jacket on the sample tube when performing analyses at temperatures above ambient; see [Use a Metal Jacket on the Sample Tube on page J - 6](#).
- Close the door on the vapor enclosure.

SPECIFY ANALYSIS PARAMETERS

Create standalone parameter files for analysis conditions and adsorptive properties for the materials typically analyzed.

The values used in the following example are for silica-alumina reference material having a relatively large pore volume and analyzed at 25 °C with water vapor derived from a 35 °C source.

Analysis Conditions

Create an analysis conditions parameter file using the parameters in the following table:

Button	Enter or select
Insert Range	<ol style="list-style-type: none"> 1. Enter the values: <ul style="list-style-type: none"> • Starting relative pressure. 0.01 • Ending relative pressure. 0.9 • Number of points. 50 2. Click OK. 3. Click Insert Range again. Enter the values: <ul style="list-style-type: none"> • Starting relative pressure. 0.99 • Ending relative pressure. 0.45 • Number of points. 6 4. In the pressure table, scroll to point number 51. <ol style="list-style-type: none"> a. Click Insert to insert a new row. b. Enter 0.95 The table should now display 57 points.

Button	Enter or select
Preparation	<ul style="list-style-type: none"> • Unrestricted evac. from. 10.0 mmHg • Vacuum setpoint. 10 mmHg • Evacuation time. 0.50 hours
Free Space	<ul style="list-style-type: none"> • Evacuation time. 0.50 hours • Outgas test duration. Select checkbox and enter 180 seconds.
P ₀ and T	<ul style="list-style-type: none"> • Select <i>Calculate P₀ from the analysis temperature.</i> • Select <i>Enter the analysis temperature</i> then enter an analysis temperature of 25.0 °C.
Dosing	<ul style="list-style-type: none"> • Absolute pressure tolerance. 2.000 mmHg • Relative pressure tolerance. 5.0 %
Equilibration	<ul style="list-style-type: none"> • Minimum equilibration delay. 600 s
Backfill	<ul style="list-style-type: none"> • Disable both backfill options. <hr/> <div style="display: flex; align-items: flex-start;">  <ul style="list-style-type: none"> • When the <i>Backfill</i> option is disabled at the start of an analysis, the sample must be evacuated before analysis. • When <i>Backfill sample</i> is deselected, a message displays indicating that disabling this option may damage the instrument. When dosing water vapor, there is no risk of generating high pressures; therefore, it is safe to deselect this option. Click Yes, then OK to close the window. </div> <hr/>

Adsorptive Properties

1. Create an adsorptive properties file.

If the adsorption test is solely for the purpose of discovering how water is taken up by the sample, the *Density conversion factor*, *Therm. tran. hard-sphere diameter*, and *Molecular cross-sectional area* values are of little consequence. All that is needed is the adsorption isotherm and, perhaps, the desorption isotherm.

- a. **Non-ideality factor** derived as

$$NIF = \frac{\frac{1}{z(P_0, T_{analysis})} - 1}{P_0}$$

where

- Z = compressibility factor at the saturation pressure of the vapor
 T = analysis temperature

- b. **Density conversion factor** derived as:

$$DCF = \frac{V_m}{22414 \text{ cm}^3/\text{mol}}$$

where

- V_m = molar volume of the liquid at the analysis temperature

- c. **Thermal Transpiration hard-sphere diameter.** Enters into calculations when high precision requires that low-pressure measurements take into account small differences in temperature along gas passageways. The subject is thoroughly treated in Ross Sidney and Olivier, James P., *On Physical Adsorption*, Interscience Publishers, NY, 1964.
- d. **Molecular cross-sectional area.** Required when, from the isotherm, the surface area of the sample material is to be calculated. The technical literature, beginning with the extensive tabulation of McClellan and Harmsberger [“Cross-sectional Areas of Molecules Adsorbed on Solid Surfaces,” *J. Coll. and Interface Sci.* 23, 577-99 (1967)], is replete with adsorbed cross-sectional areas on various substrates at different temperatures. In the case of silica-alumina and water, these values range from 0.108 to 0.198 nm². A value of 0.125 nm² gives BET surface area results that agree well with nitrogen analyses.

2. Click **Psat vs T**; enter:

Row	Saturation Pressure (mmHg)	Temperature °C
1	4.584	0.0000
2	9.209	10.000
3	23.776	25.000

USE A METAL JACKET ON THE SAMPLE TUBE

A two-piece metal jacket is included in the accessories kit to use when performing analyses at temperatures above ambient. The jacket helps to maintain strictly decreasing temperatures from the instrument to the sample in order to prevent condensation in the portion of the tube above the sample. The sample may be degassed with the jacket in place. Install the jacket on the tube before attaching the sample tube to the sample port.

1. Wear latex gloves and place a retaining O-ring onto the sample tube. Slide the O-ring toward the bulb.



The O-rings for the metal jacket are larger than the ones for the sample port. Do not attempt to use sample port O-rings for retaining the jacket, or vice versa.

2. Position both sides of the metal jacket on the sample tube and slide the O-ring into the lower groove of the jacket.
3. Slide the other O-ring onto the top of the sample tube and into the upper groove of the jacket. The top of the jacket should be approximately 3 cm (1 in.) from the top of the tube to allow for installation in the sample port



4. Attach the sample tube to the sample port.
5. Gently slide the jacket upwards until it touches the sample tube connector nut.

PERFORM AN ANALYSIS AT ICE WATER TEMPERATURE

1. Create a sample file using the analysis conditions and adsorptive properties for water. To replace parameters from the *Analysis Conditions* parameter file created previously in this document, use the **Replace All** button on the *Sample Description* tab.
2. Degas the sample to its required conditions.
3. Prepare the ice-slush bath and place on the elevator.
4. Transfer the sample tube from the degas port to the analysis port.
5. Manually evacuate the sample using the instrument schematic.

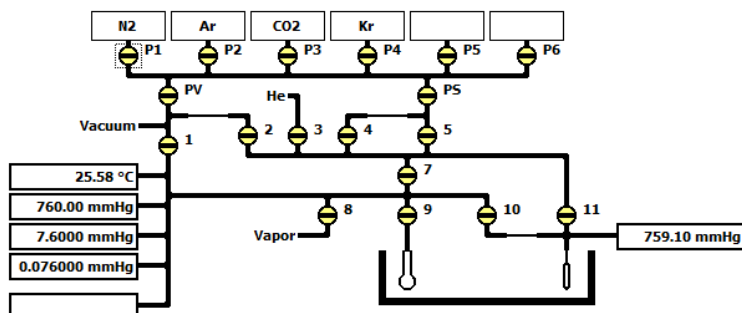

- a. Ensure all valves are closed.
 - b. Open valves N2 and PS.
 - c. Open valves 5 and 7. When 760 mmHg is achieved, close valves 5 and N2.
 - d. Open valve PV. Wait approximately 10 seconds, then close valves PV and PS.
 - e. Open valves 9 and 2.
 - f. At 10 mmHg, open valve 1 and close valve 7.
 - g. At 10 mmHg, evacuate for 30 minutes.
6. Raise the elevator.
 7. Start the analysis.

Example of an isothermal linear plot using the analysis conditions parameter file created in this document:

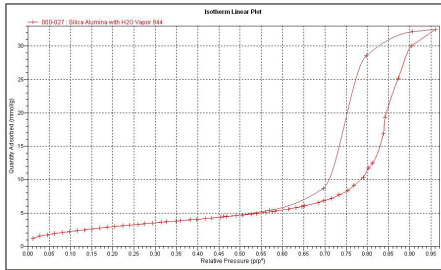

Isotherm for water vapor adsorption on Silica Alumina reference material

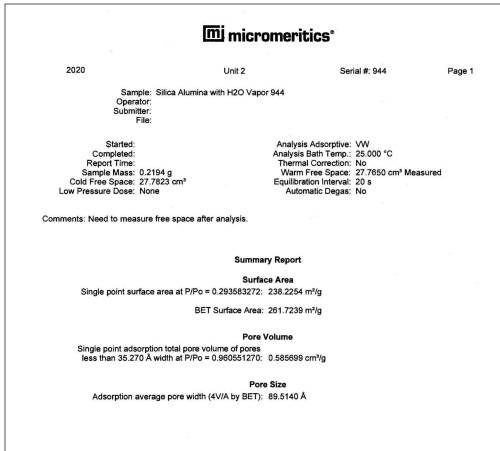

Summary Report for water vapor adsorption on Silica Alumina reference material

VAPOR SOURCE MAINTENANCE

It is very important to use high-purity, certified liquids as vapor sources. When using water, a common vapor source, ensure it is distilled or deionized. Use extra care to ensure proper degassing.

The level of the liquid in the vapor tube should be at 25 to 50% of the tube, approximately 3 to 5 mL. If the level falls below 25%, add more vapor liquid and degas thoroughly.

CLEAN THE VAPOR SOURCE TUBE

A clean vapor source tube is as important as high-purity vapor sources. Clean the tube when changing vapor sources or when the vapor source becomes discolored

1. Preheat a drying oven to 110 °C.
2. Check the bowl of the ultrasonic cleaning unit to ensure it is clean.
3. Use five grams of Alconox[®] (or other suitable laboratory detergent) per 500 mL of warm water and fill the reservoir of the ultrasonic unit with enough water to cover the vapor tube. Ensure the detergent is dissolved prior to placing the vapor tube into the water. If too much detergent is used, it may be difficult to rinse from the tube.
4. Fill the vapor tube with warm water and place it in the ultrasonic cleaning unit. Power on the ultrasonic cleaning unit for approximately 15 minutes.
5. Remove the vapor tube from the reservoir.
6. Clean the interior of the tube with a sample tube brush.
7. Rinse the vapor tube with hot water, then with isopropyl alcohol. If isopropyl alcohol is not available, deionized water may be used to rinse the tube.
8. Stand the vapor tube on a sample tube rack and place the rack in the preheated drying oven for two hours.
9. Remove the tube from the oven and allow to cool.

DEGAS THE VAPOR SOURCE TUBE

Vapor source liquids must be degassed thoroughly to remove air (and other dissolved gases) to achieve desirable results. It is very important to degas vapor liquids on a weekly basis to maintain purity.

Degas vapor liquids:

- on a regular, weekly basis
- when adding fresh vapor liquid
- when changing vapor liquids

The vapor tube may be degassed by using the vacuum method or the freezing method. The vacuum method is generally sufficient.

Vacuum Method

1. Ensure the cold trap dewar has been removed.
2. Display the instrument schematic and enable manual control. Ensure all valves are closed. Valves 1 (vacuum), 7 (isolation), and 8 (vapor) will be used.



Do not open Valves 1 and 8 concurrently. Doing so may cause damage to the instrument.

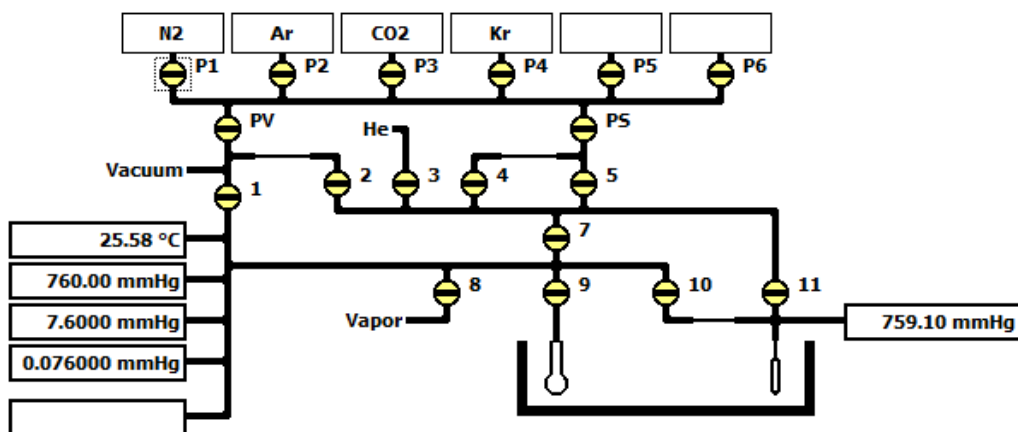

3. Open valves 1 and 7. Wait until the vacuum gauge reading is 10 mmHg (approximately 5 min).
4. Close valve 1 and open valve 8; wait approximately 2 min.
5. Close valve 8 and open valve 1; wait approximately 2 min.

- Repeat Steps (3) and (4) six times so that the vapor source will be degassed thoroughly (or until the 1000 mmHg transducer reads between 40 and 45 mmHg for water at 35 °C in the vapor enclosure).



The pressure in the manifold will vary if using a vapor other than water at 35 °C. Refer to a *Saturation Pressure vs. Temperature* table to determine the appropriate pressure for the vapor being used.

Freezing Method

The vacuum method is typically sufficient for degassing water. However, the freezing method may be used when maximum purity is required.



It is very important to degas vapor source liquids on a weekly basis to maintain purity.

- Place a dewar of LN2 on the instrument cold trap and another dewar of LN2 about the vapor tube using the supplied dewar and stand.
- Open valve 8 and evacuate until a vacuum of 10 mmHg is achieved.
- After 30 minutes, remove the LN2 from the vapor tube and close valve 8.
- When the water in the vapor tube warms nearly to ambient temperature, open valve 8 and allow evacuation to proceed for 10 minutes.
- Close valve 8.

REPLACE FUSE IN TEMPERATURE CONTROLLER

A fuse block is located in the input power connector on the back of the temperature controller. A single or double fuse arrangement can be used depending on the power source.

Power Source	Fuse
100-120 VAC	Use one 5 Amp, slow-blow
200-240 VAC	Use two 3.15 Amp, 5 × 20 mm, slow blow



The fuses used in the temperature controller must be identical in type and rating to those specified. Use of other fuses could result in electrical shock and/or damage to the unit.

1. Power off the temperature controller and disconnect the power cord. The cover of the input power connector cannot be opened when the power cord is installed.
2. Insert the tip of a small screwdriver into the top of the power module. Gently pry the cover open.

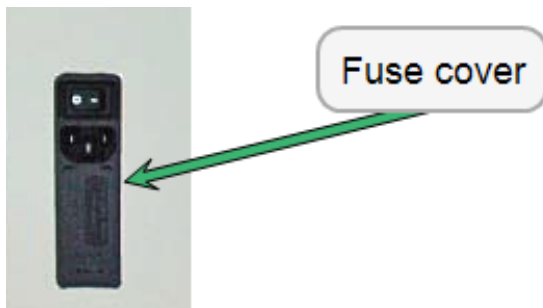

3. The cover is hinged and cannot be removed. Gently grasp the bottom of the cover and swing it upward.
4. Hold the cover open and remove the fuse block. Needle-nose pliers may make removal easier.

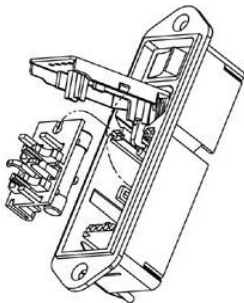

5. Replace the blown fuse.
6. Re-insert the fuse block into the input power connector.
 - Single fuse arrangement. Position the fuse block so that the single-fuse slot and the jumper bar are away from the cover.
 - Double fuse arrangement. Position the fuse block so that the double-fuse slots are away from the cover.
7. If using the single fuse arrangement, snap the fuse block into place, then close the cover. If using the double fuse arrangement, the block will not snap into place. Position the fuse block in the proper orientation to seat it properly.
8. Reconnect the power cord and power on the temperature controller. Allow at least four hours for the manifold temperature to stabilize.



Do not adjust the manifold temperature to speed the process. If the manifold temperature is changed, recalibration by a Micromeritics Service Representative is required.

Blank Page

K WORKSHEETS

Worksheets in this section may be copied as needed.

- [*Input Gas Worksheet on page K - 4*](#)
- [*Sample Data Worksheet for Gas Adsorption on the next page*](#)
- [*Valve Test Worksheet for ASAP 2020 on page K - 3*](#)

VALVE TEST WORKSHEET FOR ASAP 2020

Valve	P1 (1st Pressure Reading)	P2 (2nd Pressure Reading)	Outgassing Rate
Analysis Valves			
Manifold			
Gas inlet valves			
3			
P1			
P2			
P3			
P4			
P5			
P6			
PS			
5			
7			
10 and 11			
9			
8			
1, 2, and PV			
1, 2, and PV			
1			
Degas Valves			
Manifold			

INDEX

A

about this manual *iv*
active metals 3 - 9
adsorptive properties 4 - 2
advanced report options 8 - 1
Alpha-S method report 8 - 2
analysis
 perform 6 - 1
 prepare for 6 - 3
 sequence 6 - 23
analysis conditions 4 - 5
 chemical adsorption tasks 4 - 14
analyzer
 components 1 - 1, 1 - 6
 configure 2 - 15
 show status 2 - 22
 software 2 - 1
atomic weights A - 1

B

BJH
 plot options 8 - 10
 report options 8 - 6
 tabular report options 8 - 11
Broekhoff-de Boer
 model F - 15

C

calibrate
 furnace resistance 10 - 1
 pressure zero 10 - 2
calibration 10 - 1
 cryostat D - 9
 load from file 10 - 3
 save to file 10 - 3
chemical adsorption
 methods
 carbon monoxide analysis of
 platinum C - 1

port assembly 11 - 3
tasks 4 - 14
clean
 analyzer exterior 12 - 11
 dewar 12 - 10
 filler rod 6 - 5
 sample tubes 6 - 5
cold trap 11 - 1
 clean tube 12 - 12
components analyzer 1 - 1
configuration
 unit 2 - 15
contact us *iii*
control chart report 7 - 7
corporate profile *ii*
cryostat
 about D - 1
 calibration D - 9
 elevator D - 1
 enable D - 1
 operating instructions D - 1
 preventive maintenance D - 8
 remove from analyzer D - 4
 rotameter scale readings D - 3
 sample tube, install D - 2
 troubleshooting D - 5

D

data
 manually enter 3 - 5
data chemisorption temperature ramp data E
 - 7
data logging E - 1
degas
 conditions 4 - 18
 manual control 5 - 5
 samples 6 - 13
 show schematic 5 - 7
 show status 5 - 6
 start 5 - 1
degassing 5 - 1
 sample transfer to analysis port, chemical
 adsorption 5 - 4
 sample transfer to analysis port, physical
 adsorption 5 - 2

dewar
 check 12 - 10
 clean 12 - 10
 fill and install 6 - 19
 precautions 6 - 1, 6 - 1, 6 - 19

DFT
 model references *F* - 17
 models based on classical theories *F* - 13
 models based on statistical thermodynamics *F* - 1
 models, all
 Broekhoff-de Boer model *F* - 15, *F* - 16
 models included *F* - 14
 pore size *F* - 13
 pore size report
 options 8 - 12
 regularization 8 - 13, 8 - 13
 surface energy report options 8 - 14

DFT Models *F* - 1

diagnostics 9 - 1
 save files for problem diagnosis 9 - 5
 schedule 9 - 3, 9 - 3
 show all readings 9 - 6
 start test 9 - 1
 test report 9 - 4

Difference method 8 - 51
 report 8 - 15

Dollimore-Heal
 plot options 8 - 21
 report options 8 - 18
 tabular report 8 - 22

Dubinin
 pore volume report options 8 - 25
 report options 8 - 23
 tabular report options 8 - 26
 transformed isotherm plot options 8 - 27

E

elevator, lubricate drive assembly 12 - 13
 equipment options and upgrades 1 - 8
 evacuation rules 4 - 17
 evaluate report results 7 - 11
 export files 2 - 23
 exported data example *G* - 1

F

f-Ratio method report 8 - 28

fields and buttons, common 2 - 3

files
 default locations 2 - 6
 description 2 - 6
 export 2 - 23
 extensions 2 - 6
 list 2 - 23
 open a sample file 3 - 5
 status 2 - 6

filler rod, clean 6 - 5

filter
 port 12 - 14
 replace 12 - 14
 replace analysis 12 - 14
 replace degas 12 - 17
 replace exhaust 12 - 15

flowmeter conversion factors *H* - 1

free space
 calculating values for micropore analyses *B* - 1

Freundlich report 8 - 30

furnace
 attach 11 - 4
 calibrate resistance 10 - 1
 chemical adsorption port assembly 11 - 3
 installation 11 - 3

fuses
 vapor adsorption option, replace fuse, temperature controller *J* - 12

G

gas
 depleted cylinder 12 - 5
 guidelines for connecting 12 - 3
 ports, specify 2 - 15
 replacement cylinder 12 - 4, 12 - 6
 requirements 1 - 9
 set flow rates 12 - 7

graph
 features and shortcuts 7 - 20
 generate overlays 7 - 26

H

Halsey, thickness curve *F* - 14
hardware installation 11 - 1
Harkins and Jura, thickness curve *F* - 15
heat of adsorption report 7 - 2
heating mantle installation 11 - 5
Horvath-Kawazoe
 plot options 8 - 36
 report options 8 - 33
 tabular report options 8 - 36

I

input gas worksheet *K* - 4
install
 furnace 11 - 3
 heating mantle 11 - 5
 Mass Spectrometer 11 - 6
 sample tube, physical adsorption 6 - 16
instrument status 2 - 18
interactive reports 7 - 10
isotherm report option 8 - 37

K

kernel function *F* - 14, *F* - 15

L

Langmuir
 report option 8 - 39
libraries 2 - 12
list files 2 - 23
log
 show instrument 2 - 18

M

maintenance 12 - 1
 clean analyzer exterior 12 - 11
 cold trap 12 - 12

 guidelines for connecting gases 12 - 3
 preventive 12 - 9
 replace analysis port filter 12 - 14
 replace degas port filter 12 - 17
 replace exhaust port filter 12 - 15
 replace port filters 12 - 14
 replacement cylinder 12 - 4
 specify gas ports 2 - 15
 vacuum pump 12 - 8
manual control
 degas ports 5 - 5
 enable 12 - 13
manual, about this *iv*
mass spectrometer
 install 11 - 6
menu structure 2 - 2
methods, about 2 - 13
MicroActive reports 7 - 11
MP-Method
 plot report options 8 - 44
 report options 8 - 42
 tabular report options 8 - 45

N

NLDFT advanced PSD report 8 - 46

O

operating instructions, cryostat *D* - 1
option presentation 2 - 10
options report 8 - 50
overlays
 generate 7 - 26
 multiple graph 7 - 26
 sample file 7 - 29

P

parameter files
 about 4 - 1
 adsorptive properties 4 - 2
 analysis conditions 4 - 5
 degas conditions 4 - 18
 file name extensions 4 - 1

- report options 4 - 20, 4 - 20
- sample tube 4 - 23
- perform an analysis
 - vapor adsorption option, ice water temperature J - 7
- plot options
 - BJH 8 - 10
 - Dollimore-Heal 8 - 21
 - Dubinin transformed isotherm 8 - 27
 - Horvath-Kawazoe 8 - 36
 - MP-Method 8 - 44
- pore distribution data, import 7 - 32, 7 - 32
- pore size F - 13
- power analyzer on and off 12 - 21
- power failure, recover from 12 - 21
- pressure zero, calibrate 10 - 2
- preventive maintenance 12 - 9
 - cryostat D - 8
- Psat
 - tube, replace O-ring 12 - 17
- pump
 - oil-based vacuum pump 12 - 8
- Python module I - 1
 - acquire basic information I - 8
 - acquire overlay sample data I - 13
 - acquire report results I - 11
 - advanced reports I - 1
 - get adsorptive data I - 24
 - get imported pore data I - 26
 - get metal composition I - 27
 - get report results I - 25
 - get sample information item I - 24
 - graphic report I - 19
 - MicModule Python calls I - 17
 - get overlay isotherm data I - 22
 - get primary isotherm data I - 21
 - overlay data I - 16
 - reports I - 5
 - scripts I - 3
 - summary report I - 18
 - tables I - 17

Q

- quartz filter discs 6 - 11

R

- references, DFT models F - 17
- regression report 7 - 5
- report examples
 - Horvath-Kawazoe differential pore volume plot 7 - 33
 - isotherm log report 7 - 34
 - isotherm tabular report 7 - 35
 - options report 7 - 36
- reports
 - about 7 - 1
 - advanced report options 8 - 1
 - advanced, Python module I - 1
 - Alpha-S method 8 - 2
 - BET surface area 8 - 4
 - BJH
 - adsorption/desorption 8 - 6
 - plot options 8 - 10
 - tabular report 8 - 11
 - Control Chart 7 - 7
 - DFT pore size 8 - 12
 - DFT surface energy 8 - 14
 - Difference method 8 - 15, 8 - 51
 - Dollimore-Heal
 - adsorption/desorption 8 - 18
 - plot options 8 - 21
 - tabular report 8 - 22
 - Dubinin 8 - 23
 - pore volume 8 - 25
 - tabular 8 - 26
 - transformed isotherm plot 8 - 27
 - evaluating report results 7 - 11
 - examples 7 - 33
 - f-Ratio method 8 - 28
 - features and shortcuts 7 - 16
 - graphs 7 - 20
 - reports 7 - 16
 - Freundlich 8 - 30
 - generate graph overlays 7 - 26
 - generate sample file overlays 7 - 29
 - heat of adsorption 7 - 2
 - Horvath-Kawazoe 8 - 33
 - plot options 8 - 36
 - tabular report options 8 - 36
 - interactive 7 - 10

- isotherm 8 - 37
- Langmuir 8 - 39
- MicroActive 7 - 11
- MP-Method 8 - 42
 - plot report options 8 - 44
 - tabular report options 8 - 45
- NLDFT Advanced PSD 8 - 46
- options 4 - 20, 4 - 20, 8 - 50
- regression 7 - 5
- sample log 8 - 50
- selected 8 - 1
- Sinfelt method 8 - 15, 8 - 51
- SPC report options 7 - 4
- summary report options 8 - 52
- t-Plot report options 8 - 54
- Temkin 8 - 57
- user-defined 8 - 1
- validation report options 8 - 60

reports, Python module 1 - 5

rotameter scale readings *D* - 3

S

- sample
 - degas 6 - 13
 - log
 - report 8 - 50
 - mass, determine 6 - 8
 - transfer to analysis port, chemical adsorption 5 - 4
 - transfer to analysis port, physical adsorption 5 - 2
- sample analysis
 - perform 6 - 21
- sample data worksheet *K* - 2
- sample file
 - create 6 - 7
 - defined 3 - 1
 - open 3 - 5
 - overlays 7 - 29
- sample files 3 - 2
- sample tube
 - clean and label 6 - 5
 - cryostat *D* - 2
 - install, physical adsorption 6 - 16
 - installation 11 - 6

- on schematic 2 - 20
- parameter file 4 - 23
- quartz filter discs 6 - 11
- replace the O-ring 12 - 18
- select 6 - 4
- schematic
 - degas 5 - 7
 - shortcuts 2 - 21, 5 - 8
- schematic, instrument 2 - 19
- service test mode 12 - 8
- shortcuts
 - application 2 - 8
 - schematic 2 - 21, 5 - 8
- show instrument log 2 - 18
- Sinfelt method
 - report 8 - 15, 8 - 51
- software
 - about 2 - 1
 - setup 2 - 1
 - updates 2 - 24
- Software Uninstall 2 - 24
- SPC report 7 - 4
- specifications, ASAP 2020 1 - 10
- status
 - analyzer 2 - 22
 - instrument 2 - 18
 - show degas 5 - 6
- summary report
 - options 8 - 52
- surface energy *F* - 13
- system valves 5 - 8

T

- t-Plot
 - report options 8 - 54
- tabular reports
 - BJH 8 - 11
 - Dollimore-Heal 8 - 22
 - Dubin 8 - 26
 - Horvath-Kawazoe 8 - 36
 - MP-Method 8 - 45
- Temkin report options 8 - 57
- temperature controller
 - replace fuse *J* - 12
- temperature controller, replace fuse *J* - 12

thickness curve
 Halsey *F - 14*
 Harkins and Jura *F - 15, F - 15*
troubleshooting
 and maintenance *12 - 1*
 elevator drive assembly, lubricate *12 - 13*
 manual control, enable *12 - 13*
 power failure, recover from *12 - 21*
 Psat tube, replace O-ring *12 - 17*
 sample tube O-ring *12 - 18*
 service test mode *12 - 8*
cryostat *D - 5*

sample data *K - 2*
valve test *K - 3*

U

unit configuration, specify gas ports *2 - 15*
unit selections *2 - 17*
user-defined report options *8 - 1*

V

vacuum pump
 oil-based *12 - 8*
validation, report options *8 - 60*
valve test worksheet *K - 3*
vapor adsorption option *J - 1*
 degas vapor tube *J - 10*
 metal Jacket on sample tube *J - 6*
 perform an analysis, ice water
 temperature *J - 7*
 vapor analysis *J - 3*
 vapor source tube, clean *J - 9*
vapor source
 maintenance *J - 9*
 tube
 clean *J - 9*
 degas *J - 10*

W

warranty *i*
worksheets *K - 1*
 input gas *K - 4*